



FOR APPROVAL

OPEN SESSION

TO: Governing Council

SPONSOR: Scott Mabury, Vice President, Operations and Real Estate
CONTACT INFO: Partnerships
416-978-2031, scott.mabury@utoronto.ca

PRESENTER: See above.
CONTACT INFO:

DATE: March 5, 2026 for March 12, 2026

AGENDA ITEM: 5

ITEM IDENTIFICATION:

Capital Project (Level 3): University of Toronto Facilities & Services Project Concept Report for the Climate Positive Campus – Project LEAP 2.0 - Project Scope and Sources of Funding

JURISDICTIONAL INFORMATION:

The Policy on Capital Planning and Capital Projects provides that capital projects with costs in excess of \$50 million (Approval Level 3) on the St. George campus, will first be considered by the Planning & Budget Committee, which shall recommend approval to Academic Board. Following consideration by the Academic Board and approval for execution by the Business Board, such proposals are then submitted to the Executive Committee for endorsement and then forwarded to the Governing Council for approval. [Section 3(b)(ii)(1)(b) and (d)] The Policy further states that "any financing will be approved by the Business Board". [Section 3(c)].

GOVERNANCE PATH:

A. Total Project Cost, and Sources of Funding:

1. Planning and Budget [for recommendation] (February 11, 2026)
2. Academic Board [for recommendation] (February 26, 2026)
3. Executive Committee [for endorsement and forwarding] (March 12, 2026)
4. **Governing Council [for approval] (March 26, 2026)**

B. Execution of the Project:

1. Business Board [For approval] (March 4, 2026)

PREVIOUS ACTION TAKEN:

In 2021, the Climate Positive Campus Plan was presented to Governing Council.

HIGHLIGHTS:

The University of Toronto’s commitment to become climate positive is strong—it is also forward-looking. Decisive and impactful action must be taken today.

On the University’s journey to become climate positive, Facilities and Services is continuing the bold initiative called Climate Positive Leap (Low Emissions Accelerator Project), with Project Leap 2.0.

Project Leap 2.0 will eliminate more than 82% of current scope 1 and scope 2 carbon emissions (estimated total reduction of 3,117 metric tons per year) in five University of Toronto owned buildings.

Project Leap 2.0 goals:

- Eliminate >3000 metric tons of CO₂ annually, representing 80% of our 2023/24 Scope 1 and 2 emissions
- Reduce at least 40% energy use
- Add energy system resiliency in the buildings
- Address a significant portion of deferred maintenance needs in these buildings

Project Leap 2.0 scope:

Project LEAP 2.0 combines several items to a mutual advantage; Addressing deferred maintenance needs, expanding energy infrastructure to allow for future programmatic growth, and reducing our carbon emissions. The initiative impacts 5 buildings over 3 sites - Dentistry Building, Rehabilitation Sciences Building and the McCaul group of buildings (Health Sciences Building, Exam Centre, Old Admin Building). The Project Scope includes:

1. Climate Positive initiative

- Decarbonization of building emissions by electrification of heating, humidification, domestic hot water and lab sterilization
- Reduction of energy use through implementing heat recovery and heat pumps to reuse wasted heat
- Improved efficiency and reliability of building heating and cooling ventilation through modernization of building automation systems
- LED lighting retrofits
- Installation of 150kW Solar PV panels
- Insulation of ventilation spaces to reduce energy usage

- 2. Asset renewal for end of Life (Deferred Maintenance)
 - Reduction of steam network
 - Ventilation system renewal, and associated heating and cooling
 - Replacement of obsolete controls in critical spaces
 - Replacement of end-of-life electrical systems
- 3. Benefits to Dentistry program space
 - Increased electrical capacity for future expansion considerations
 - Additional ventilation and humidification to Clinic space (1 and pediatric)
 - Adding resiliency to Clinic 2 by enabling connection to building heating and cooling network over a standalone system
 - Connection of perimeter heating to emergency power

Project Leap 2.0 is fully aligned with the goals of the climate positive strategy, while also significantly mitigating deferred maintenance liabilities. In achieving the primary project objective of reducing net carbon emissions for the buildings retrofit by 82%, we will continue our transition away from fossil fuels as the primary heating source for our campus. The project allows the St George campus to surpass carbon reduction targets set out by all levels of government as well as the UN IPCC targets (commonly referred to as the science-based targets).

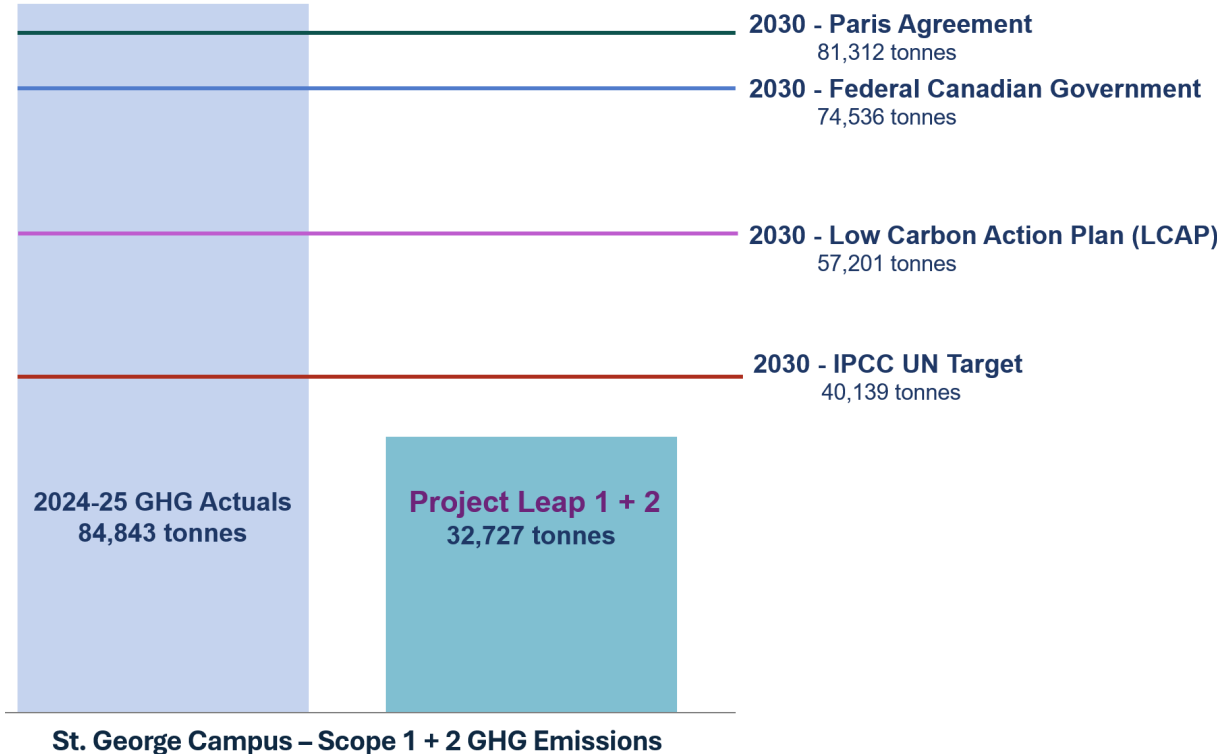

Schedule

The overall proposed project schedule is phased as follows:

- RFSQ Shortlist Announcement April 2024
- Issue of RFP to Short List June 2024
- Detailed Study March - September 2025
- Design October 2025 – March 2026
- Cycle 3 Governing Council Full Project Approval March 26, 2026
- Mobilization & Construction April 2026 – May 2028
- Anticipated Commissioning Period June 2028-May 2029
- Anticipated Guarantee Period June 2029-May 2054

This schedule assumes all municipal approvals can be achieved within the timelines.

FINANCIAL/RESOURCE IMPLICATIONS:

Discussion of overall costs and sources of funds can be found in the in-camera document for this project.

RECOMMENDATION:

Be It Resolved,

THAT the project scope of Project Leap 2.0, as identified in the Concept Reports (Faculty of Dentistry, March 19, 2023; McCaul Complex – July 8, 2022; 500 University – April 8, 2022) be approved in principle; and,

THAT the project be approved in principle to be funded through: Deferred Maintenance Funds.

DOCUMENTATION PROVIDED:

- Project Leap 2.0 Concept Reports and Technical Submissions
 - Faculty of Dentistry – March 19, 2023
 - McCaul Complex – July 8, 2022
 - 500 University – April 8, 2022

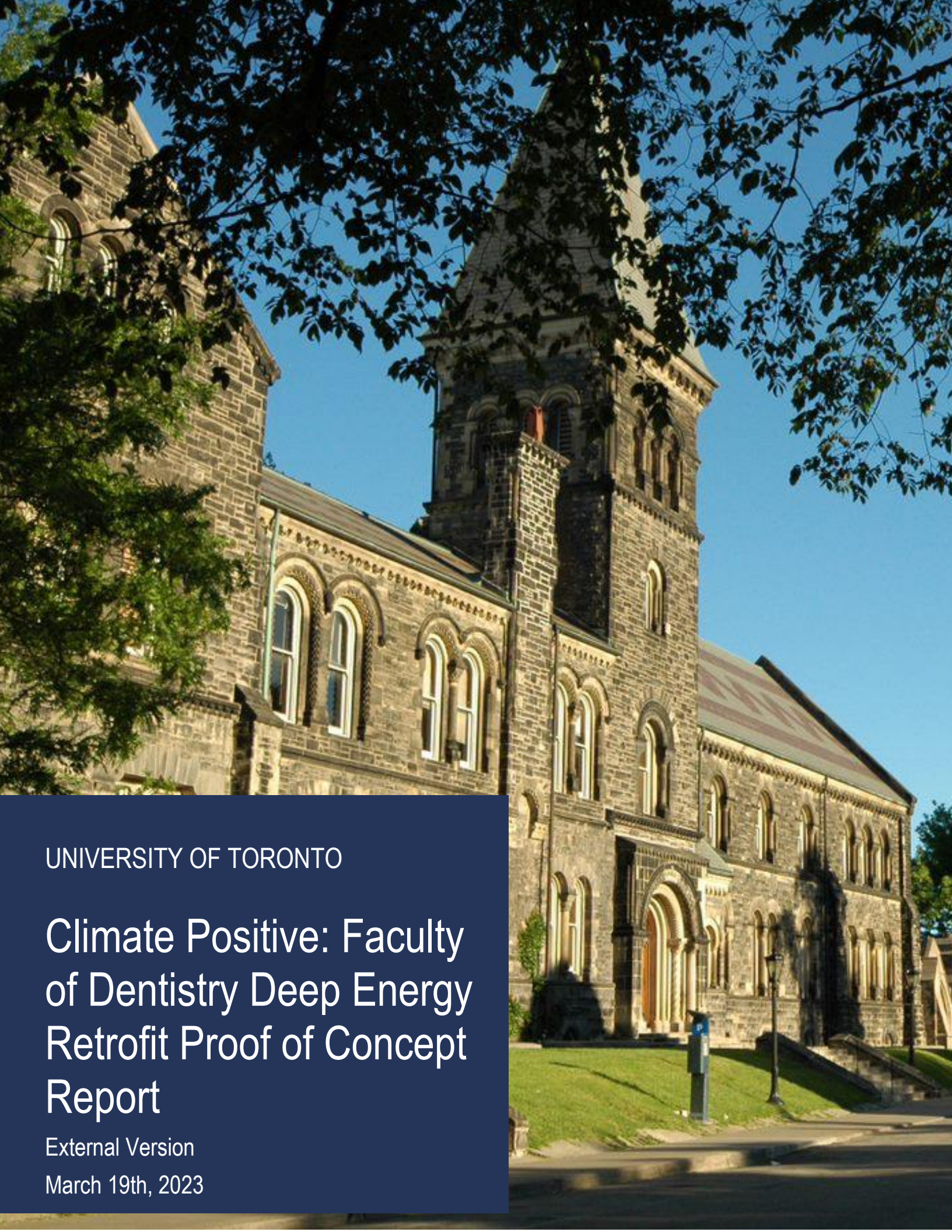

UNIVERSITY OF TORONTO

Climate Positive: Faculty of Dentistry Deep Energy Retrofit Proof of Concept Report

External Version

March 19th, 2023



TABLE OF CONTENTS

Table of Contents	1
1.0 Executive Summary	5
2.0 Background	10
2.1 Building Envelope	10
2.2 HVAC systems	10
2.2.1 Heating and cooling	10
2.2.2 Ventilation.....	16
2.2.3 Building Automation	17
2.3 Medical & Dental Gas Systems.....	18
2.4 Process Loads.....	18
2.5 Electrical system	18
2.6 Water Consumption	21
3.0 Building Performance Analysis	21
4.0 Building Systems Discussion:	26
4.1 Building Mechanical systems:	26
4.2 Building Electrical system:	27
4.3 References.....	29
5.0 Detailed Proposed Energy Conservation Measures:	30
5.1 ECM-01A Heating Plant Electrification	30
5.2 ECM 01B – DHW electrification	35
5.3 ECM 02 – Humidification electrification	38
5.4 ECM 03 – Autoclaves steam supply electrification	38
5.5 ECM 04 – Lighting Retrofit	39
5.6 ECM 05 – Building Automation System (BAS)	39
6.0 Deferred Maintenance and maintenance Items not addressed in the proposed ECMs package: .	40
6.1 Air ducts, windows and penetrations sealing.....	40
6.2 Exterior doors replacement	40
6.3 2000 KVA primary transformer replacement.....	41
7.0 Low Carbon Action Plan.....	41
8.0 Mandatory Requirements.....	42
8.1 Outcomes / Performance Metrics.....	42
8.2 U of T Design Standards.....	42



9.0	Financial Analysis	44
	Appendix A – AHU (Air Handling Units) Summary	45
	Appendix B – Existing Conditions High Level Schematic Diagram	65
	Appendix C – Proposed High Level ECMs	66
	Appendix D - Savings By Design (SBD) Workshop Simulation	67



ABBREVIATIONS

AHRI	Air Conditioning, Heating and Refrigeration Institute
AHU	Air Handling Unit
ASHRAE	American Society of Heating, Refrigerating and Air-Conditioning Engineers
ASME	American Society of Mechanical Engineers
ATS	Automatic Transfer Switch
BAS	Building Automation System
BAU	Business as Usual
BESS	Battery Energy Storage System
BOP	Balance of Plant
CED	Central Electrical Distribution
CFM	Cubic Feet per Minute
CHW	Chilled Water
CMMS	Computer Maintenance Management Systems
CMRS	Central Management and Reporting System
COP	Coefficient of performance
Cogen	Cogeneration Plant
CSP	Central Steam Plant
CSP	Central Steam Plant
CW	Condenser Water
DHW	Domestic Hot Water
EMRS	Energy Management and Reporting System
GA	Global Adjustment
GSHP	Ground Source Heat Pump
GTG	Gas Turbine Generator (Co Gen)
GPM	US Gallons per Minute
HTHW	High Temperature Hot Water
lbs/hr	Pound per Hour (Steam Flow Rate)
ISS	Ice Storage System
IESO	Independent Electricity System Operator
LDC	Local Distribution Company



LTHW	Low Temperature Hot Water
PPH	Pounds Per Hour (Steam Flow Rate)
OSHA	Occupational Safety and Health Administration
OWS	Operator Workstation
TH	Toronto Hydro
THESL	Toronto Hydro Electric System Limited
UMP	Site Utility Master Plan
UPS	Universal Power Supply
VFD	Variable Frequency Drive



1.0 EXECUTIVE SUMMARY

In recognition that climate change remains one of the most pressing challenges of our time, the University of Toronto St. George campus has committed to becoming climate positive (having net negative emissions) by 2050. Our downtown Toronto campus—the university’s largest and oldest campus—makes up over 80% of the University of Toronto’s operational carbon footprint. Our impact on the institutional footprint and our key role in the community calls for going beyond net-zero carbon emissions to become climate positive by 2050. This means not only reducing the operating emissions under our control, but also mitigating additional carbon emissions to achieve net-negative emissions,

Our first step towards becoming climate positive is to invest in transformational infrastructure renewal as part of our 30-year carbon and energy campus master plan. We are moving towards a renewed, resilient and reliable utility infrastructure that will enable our campus to operate and thrive without disruption and mitigate the impacts of growth on our carbon footprint. Our 2050 plan follows the release of U of T’s tri-campus Low-Carbon Action Plan (2019-24), which focuses on U of T’s 2030 reduction target, and will position the institution to accelerate carbon reductions towards 2050.

While proud of our 2050 plan and commitment, we realize that we need to take decisive action now. As part of the launch of the Climate Positive plan, the University is launching Deep Energy Retrofit Projects across campus to eliminate gas as a primary fuel for heating, and switch to low temperature hot water heating systems. In addition, optimizing ventilation, lighting retrofits, and adding renewable energy assets where possible while renewing aging assets.

The Faculty of Dentistry building is a 24,531 m², 5 storey building located at 124 Edward Street, 2 blocks South of University of Toronto St. George main campus. The building consists of classrooms, large lecture halls, dry labs, wet labs, and several clinics that serve the public year-round.

The building was built in 1958, an extension was added to the West wing of the building in 1982 and extends North. Being an off-Campus building, it is not connected to the St. George Campus District Network (DN) and is served by steam supplied by third party. Steam is used for perimeter heating, Air Handling Units (AHUs) heating coils, humidification, Domestic Hot Water heating, sterilization autoclaves, and ramp heating. Cooling is provided by two 250-Ton water cooled chillers and a 200-Ton air cooled chiller.

The lab floors were renovated in 2017 and received a new heating and cooling plants in addition to a new ventilation system and a dedicated building controls system. The new heating and humidification system runs on steam to deliver heating hot water, heating glycol and clean steam for humidification. The new chiller delivers chilled glycol to the new lab floors AHUs for cooling.

Faculty of Dentistry Key Objectives

- *Elimination of 1500 metric tonnes of CO₂, representing 80% of the annual Scope 1 & 2 total emissions*
- *No material impact to the building’s utility budget*
- *Added energy system resiliency by having dual fuel capability*
- *Addresses significant deferred maintenance priority*



The building is considered leaky at 5.5 L/s rate, it has single glazed windows and an aging heating and ventilation system except for the recently renovated lab floors. With reference to the baseline year used in this report 2018/2019, it has a TEUI of 523 ekWh/m2.y, and GHGI of 74.63 Kg CO2e/m2.y. and the building emits just over 1,800 tons of GHG annually, primarily scope 2.

Benchmarking

A benchmarking exercise that maps the COU weighted space categories to equivalent ASHRAE 100 categories, shows that the TEUI is higher than an ASHRAE equivalent building that would be at 323 ekWh/m2.yr

Zone 5A				
Space cat. (UofT)	Space %	Reference EUI (eKWH/m2.yr)	Reference Weighted EUI (eKWH/m2.yr)	ASHRAE estimated space category equivalent
Admin	21%	151.52	32.43	Admin
Athletic	3.90%	97.50	3.80	recreational
Lab high energy	35.30%	657.60	232.13	Lab
Libraries	3.50%	226.03	7.91	Library
Low energy Lab	30.60%	143.49	43.91	Clinic
Parking	5.30%	52.91	2.80	Vehicle storage
ASHRAE equiv. Weighted EUI			322.98	

Table 1 Benchmarking Table

When comparing to peer buildings at UofT, such as MSB, Lassonds Mining, Tanz Neuro Science, Engineering Annex, FitzGerald and Earth Science, they averaged 438 ekWh/m2.yr for the same year.

Overview of proposed measures

The University of Toronto Energy Management team conducted an energy audit of the Faculty of Dentistry (FOD) building and identified key Energy Conservation Measures (ECMs).

The goal of the ECMs identified is to meet the Deep Energy Retrofit program goals of reducing the GHG emissions by 80% and EUI by 40%.

The ECMs selected are decarbonizing the steam heating plant by electrifying heating, humidification, and process loads using a combination of electric boilers and heat pumps with gas fired boilers for peaking.

The building is estimated to exhaust approximately 127,000 CFM of conditioned air based on AHUs specs and OA intake field observations. An estimated 85,000 CFM of exhaust air is accessible through AHUs exhaust and main exhaust fans presenting an opportunity for heat recovery and a source of low-grade heat for the proposed water source Heat Pumps. The space heating electrification ECM is expected to result in a net GHG reduction of ~650 tons or 36% of the total building’s total emissions, in addition to a 49% reduction in heating energy intensity.



To achieve the above goals, the ventilation system will require optimization. An efficient ventilation system will reduce heating and cooling demand. This will require VFD fan drives where not installed and adding all active AHUs serving the building to a full building integrated BAS system. This ECM will see a complete ventilation system automation, high efficiency fan blades, damper motors replacement, and fan motors replacement with VFD drives where applicable, all which will operate in conjunction with Demand Control Ventilation (DCV). This ECM will ensure the right amount of fresh air is delivered at the right time to each space served by each AHU, and right fan power, reducing the fan loads. Further development of the concepts in this ECM will require a detailed hourly analysis of the optimized airside system to aid in assessing the available exhaust air that can economically be used for heat recovery and utilized as low-grade heat source for the proposed water source heat pumps. In addition, assess the potential of replacing free side air cooling with mechanical cooling, where available in the heating season, to further supply the WSHPs water loop through rejected heat recovery.

Although optimizing the ventilation based on occupancy for instance may reduce the volume of available exhaust air for heat recovery, it is expected that the heating demand will also be optimized through set point and ventilation rates response based on occupancy.

The Domestic Hot Water system is proposed to be converted from steam supplied heat exchangers to Low Temperature Hot Water using water heater heat pumps. This ECM will eliminate ~144 tons of CO₂.

Humidification is currently supplied to a few AHUs and primarily the lab floors. The current steam system contributes ~200 tons of CO₂ or 11% of the whole building emissions. Electrifying the humidification system using an electric steam boiler is proposed. Humidification load estimates are expected to have a high margin of error due to lack of data. This ECM can be further improved by utilizing innovative and efficient humidification technologies while observing the regulatory requirements of office, lab and clinic spaces.

The baseline year monthly energy analysis showed a significant process load with 5 Autoclaves used for sterilization and several glass wash units. An electrification project is being commissioned currently that will add 3 electric Autoclaves. However, it is not known at this time if electric Autoclaves will fully replace steam supplied Autoclaves in the near future. Based on this, a heat pump steam generator is proposed to supply steam for all baseline year active Autoclaves. The heat pump steam generator will require Low Temperature Hot Water at ~120 Degf to operate at a desired COP of ~2.5, this will require additional heat pump capacity to supply Low Temperature Hot Water to the steam generator. This measure will eliminate ~600 tons or 33% of total building's emissions. Process load estimates are expected to have a high margin of error due to lack of data.

A full building lighting retrofit and adding occupancy-based lighting controls are proposed to reduce the EUI and maintenance cost. The ECM is expected to reduce the lighting load by 55%, saving 645 MWH annually.

A study by SBC found that the building has a leakage rate of 5.5 L/S @75pa. Reducing the building's leakage will reduce the mechanical space conditioning loads. Sealing air leaks in the duct work, around windows, doors and penetrations are proposed as part of the project scope.

Finally, critical deferred maintenance items that will contribute to the energy efficiency of the building were selected. The Deferred maintenance items are replacing exterior doors that are beyond their useful life



and replacing the two primary transformers that are beyond their useful life. The new transformers will be 2,500 KVA each, adding 500 KVA of electrical capacity to serve the proposed electrification measures which will add up to 1300 KVA in the heating season peak above the baseline of 650 KVA, and will ensure spare capacity is available for future faculty space use repurposing or expansion projects. Further assessment of space and ventilation requirements are required as the design develops.

It is expected that provisions will be taken into account when sizing the HVAC and DHW systems in the detailed design phase of this project to accommodate a planned expansion of Clinic 2. The expansion will be achieved by an infill project that will take advantage of the double height ceiling of Clinic 2.

Proposed measures summary

The ECMs are expected to meet the project’s KPIs and result in a reduction in utilities cost in year 1 of ~\$404K based on 2022/2023 utility rates.

ECM ID	Electrical Savings			Thermal Savings			Total Savings	
	KWH	tCO2e	\$	MMBTU	tCO2e	\$	tCO2e	\$
FOD-ECM-01 Heating LTHW conversion	- 985,005	- 40	- 129,607.90	9,930	642	274,355.27	602	144,747.37
FOD-ECM-1B DHW Electrification	218,955	- 9	- 28,810.30	2,242	144	61,213.45	135	32,403.15
FOD-ECM-02 Humidification Electrification	- 917,177	- 38	- 120,683.07	3,130	201	85,472.06	164	- 35,211.01
FOD-ECM-03 Process Steam Electrification	- 909,459	- 37	- 119,667.49	9,312	599	254,258.38	562	134,590.88
FOD-ECM-04 Lighting Retrofit	645,028	26	84,873.46				26	84,873.46
FOD-ECM-05 Building Automation	328,811	13	43,265.28				13	43,265.28
FOD-DM-01 Air Leaks Sealing								
FOD-DM-02 Exterior Doors Replacement								
FOD-DM-03 Transformers Replacement								
Sum	- 1,618,847	- 84	- 270,630	24,614	1,587	675,299.16	1,503	404,669

Table 2 ECMs Summary



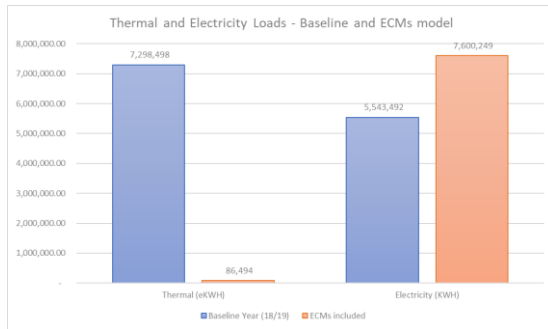

Figure 1 Energy metrics and Utilities snapshot

ECMs 1 to 4 are considered mandatory to achieve the primary objective of this project of electrifying space heating, DHW, humidification and process load energy for decarbonization. The high GHG emissions of the building is driven by Third party steam, scope 2 emissions and has high GHG emission at 64,370 gCO₂e/MMBTU.

Several risks would need to be mitigated in order to successfully implement ECM-01 - Heating LTHW conversion. The primary risks are space availability for the heat pumps, and space availability in the AHU's to add low temperature hot water heating coils, space and cost to add exhaust air heat recovery coils, and the possibility of requiring new heating loop with larger piping. In addition, the perimeter heating units when supplied with LTHW, will not supply sufficient heating energy on peak demand periods. The above risks are partially addressed by including peaking boilers that will supply the heating loops on peak heating demand days.

The anticipated new electrical demand profile will average over 1,900 KVA over the whole year presenting an opportunity to participate in the ICI program. While this might be an opportunity, it is also a risk. A peak shaving strategy will need to be developed and managed to ensure benefiting from the opportunity and avoid exposure to high GA tariffs. A second risk posed by higher electrical demand is running the transformer near its maximum rating of 2000 KVA for extended periods of time in the heating season. The building's transformers pair are intended to run at 50% capacity each to maintain full redundancy for maintenance and failure mitigation. This risk is magnified due to the age of the primary transformers. In addition, the new full capacity loading will consume any spare transformer electrical capacity for future projects. These risks are mitigated by the proposed Deferred Maintenance measure of replacing the existing 2,000 KVA transformers, that are approaching end of life with 2,500 KVA transformers.

Finally, general risks that span all the proposed measures is disturbing academic activities, climate control disturbance of the labs during construction, and asbestos management. Close coordination with property management, faculty and U of T asbestos management department will be essential to mitigate these risks. In addition, the proposed measures were selected so as to focus implementation on the heating plants, central distribution supply, and exhaust air locations, rather than dispersed measures, to mitigate the above risks.



2.0 BACKGROUND

2.1 Building Envelope

The building envelope is composed of concrete walls with brick masonry. A distinctive feature of the building are 2 curtain walls across the 2nd and 3rd floor on the South and East elevations. The North addition also features an aluminum framed glazed curtainwall with reflective vision and insulated spandrel panels. Several operable windows are on each floor. All vision units are single glazed with the exception of the newly renovated lab sections of the fourth and fifth floors. The roof is poorly insulated with several penetrations.

2.2 HVAC systems

2.2.1 Heating and cooling

1958 Original building

The building was originally designed to be heated by steam, the steam is fed from a tunnel leading to University Avenue. The existing steam header and perimeter shell and tube steam to hot water heat exchanger pair very much resemble the original 1958 design. Provisions for steam boilers were provided in room 35B (currently room 15) in the basement East wing, however, they were never used for this purpose.

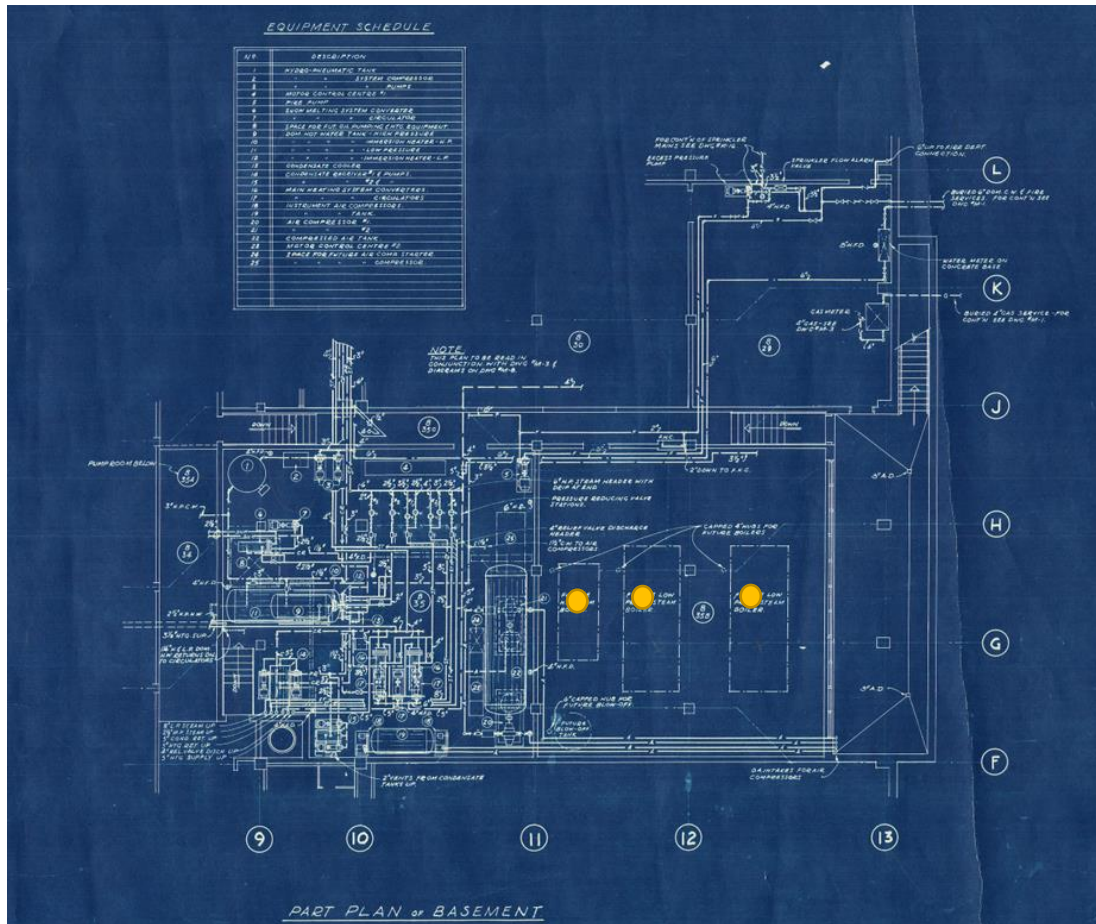

Figure 2 Original 1958 Building basement mechanical room – proposed locations of steam boilers and exhaust marked in yellow

In addition to the perimeter heating hot water, the steam also feeds two high pressure DHW tanks, a low pressure instantaneous DHW heat exchanger (added in 2020 to replace low pressure DHW tank), a snow melting steam to glycol heat exchanger, steam to glycol heat exchanger feeding the AHUs heating coils (second HX added in 1982), direct steam to the AHU’s humidifier coils, and direct steam to the sterilization autoclaves. The building was cooled by water cooled chillers.

1982 Addition

The building addition on the North side of the building was completed in 1982. The heating loads were connected to the existing steam header for expanding perimeter heating, humidification, process loads and saw adding a second glycol heat exchanger in the fifth-floor fan mechanical room to supply the new AHUs. An Air-cooled chiller was added to supply the labs on the fourth and fifth floors. The steam condensate is returned using a pumped condensate line. The remaining of the building continued to be cooled by 2x250 ton water-cooled chillers.

2017 Lab floors renovation



The fourth and fifth floors were renovated in 2017. Two new AHUs were added to serve the fourth and fifth floor lab areas and run on 100% OA. The AHUs are 20,000 CFM each and are both equipped with glycol heating coils, heat recovery coils, humidification coils and chilled glycol coils. A new heating plant was added to the roof penthouse mechanical room that includes a pair of high-pressure steam to glycol heat exchangers, a pair of high-pressure steam to hot water heat exchangers and a Clean Steam Generator (CSG) that supplies the AHU's humidification coils with low pressure steam. The glycol heat exchangers serve the two new AHUs on the fifth-floor roof, and AHU-21 that now serves the lower floors of the west wing. The hot water heat exchangers serve new VAV reheat coils in the 4th and 5th floors. The original perimeter heating radiators were removed and replaced with ceiling radiant panels that are supplied by the original perimeter heating hot water heating heat exchangers in the basement. The offices south of the labs are served by smaller AHUs – AHU-3 and AHU-31 and are equipped with cooling coils only, heating is provided by the new hot water supplied VAV reheat coils. The labs fume hoods feed exhaust air to three strobic fans. Two fans (1 & 2) operate continuously with fan 3 operating as backup. Two new Autoclaves and two glass wash units on the lab floors run on the building's high-pressure steam. In addition, a new 200-Ton air cooled chiller was added to serve the 2 new lab AHUs and supplies them with chilled glycol.

The flow diagram below reflects the current steam and water systems distribution.

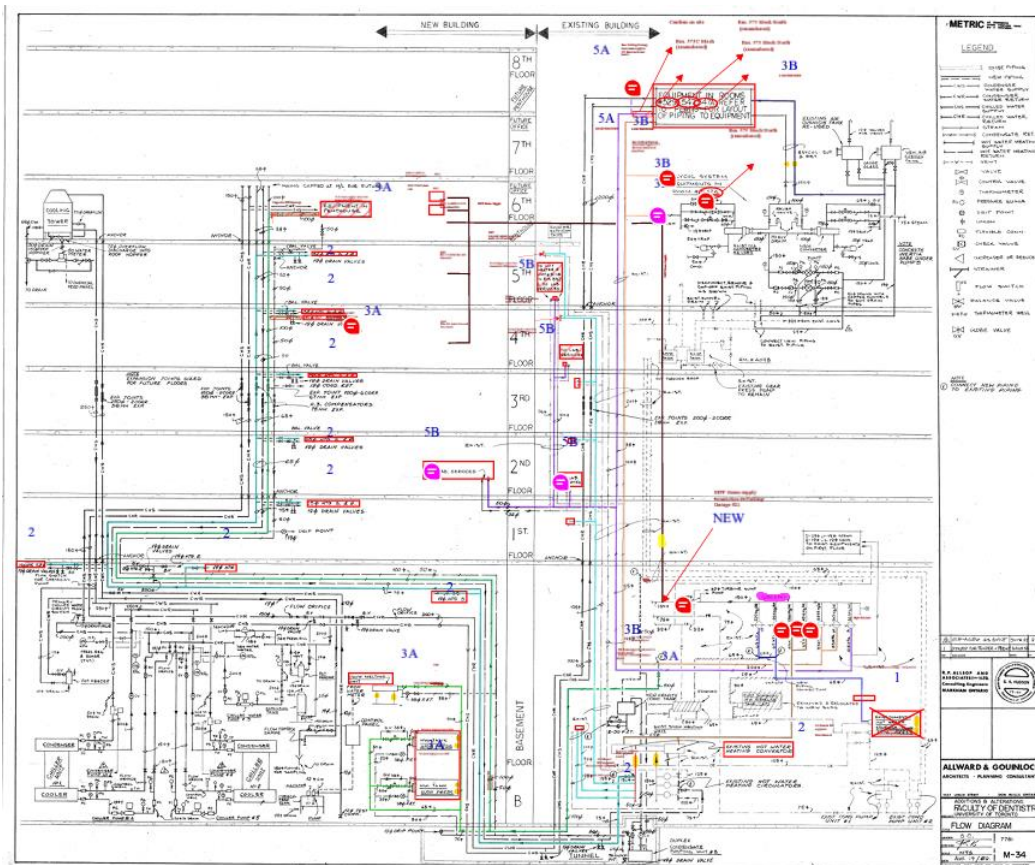

Figure 3 Marked up 1982 flow diagram reflecting 2017 retrofit changes



See Appendix B for a high-level schematic of existing systems.

The hydronics plan and EMRS building management portal snapshots below reflect the new heating plant addition to penthouse mechanical room – 2017 lab floors renovation

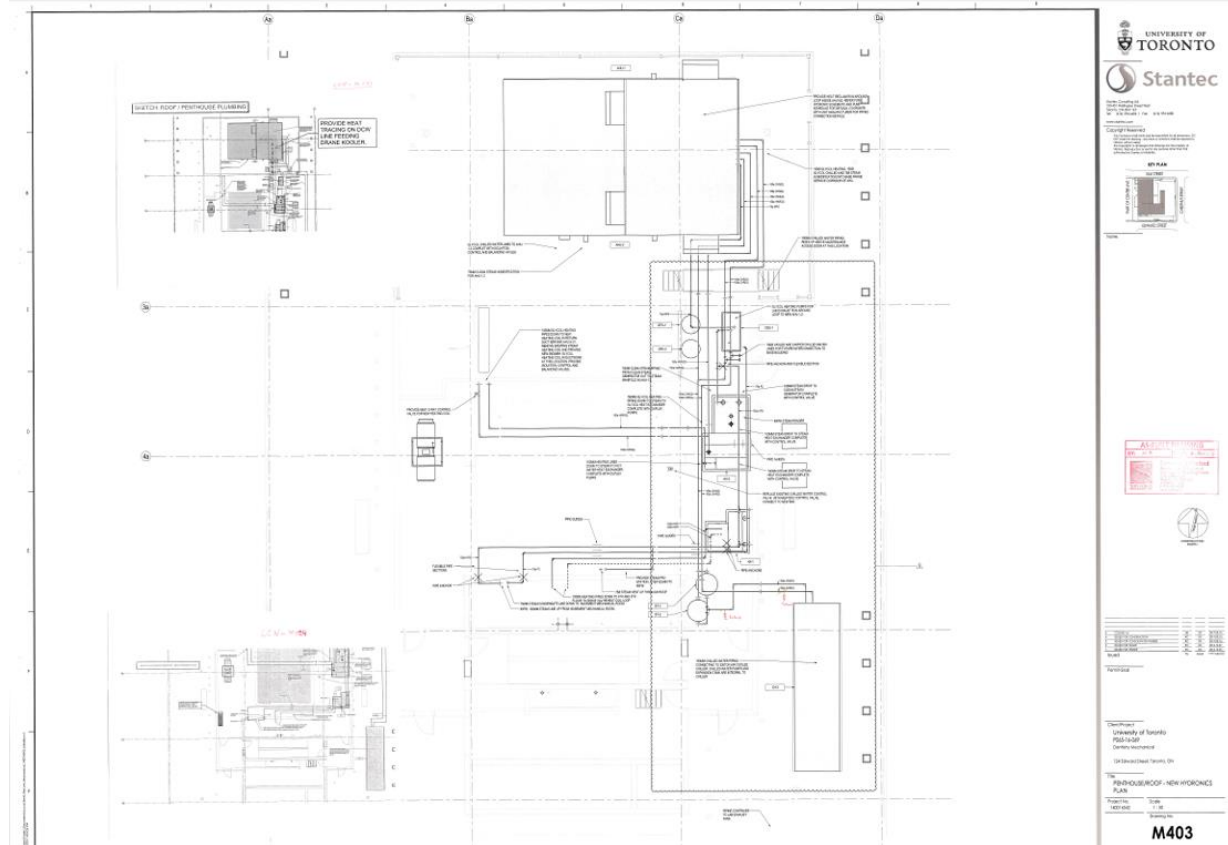

Figure 4 Penthouse Mechanical room and roof Drawing

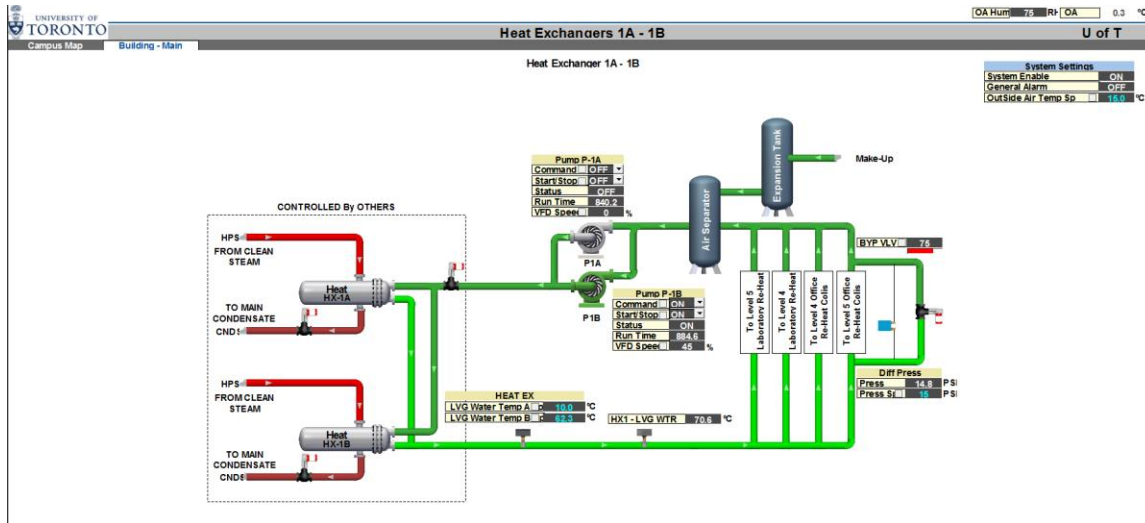

Figure 5 Penthouse Mech room (2017 Project) VAV HW Heat Exchanger

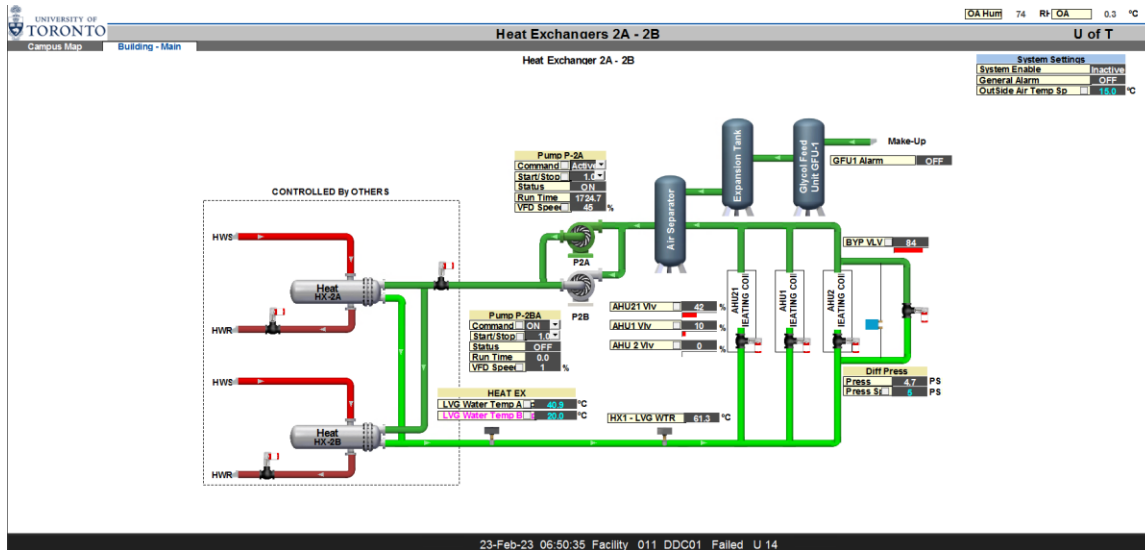

Figure 6 Penthouse Mech room (2017 project) AHU Hot Glycol System

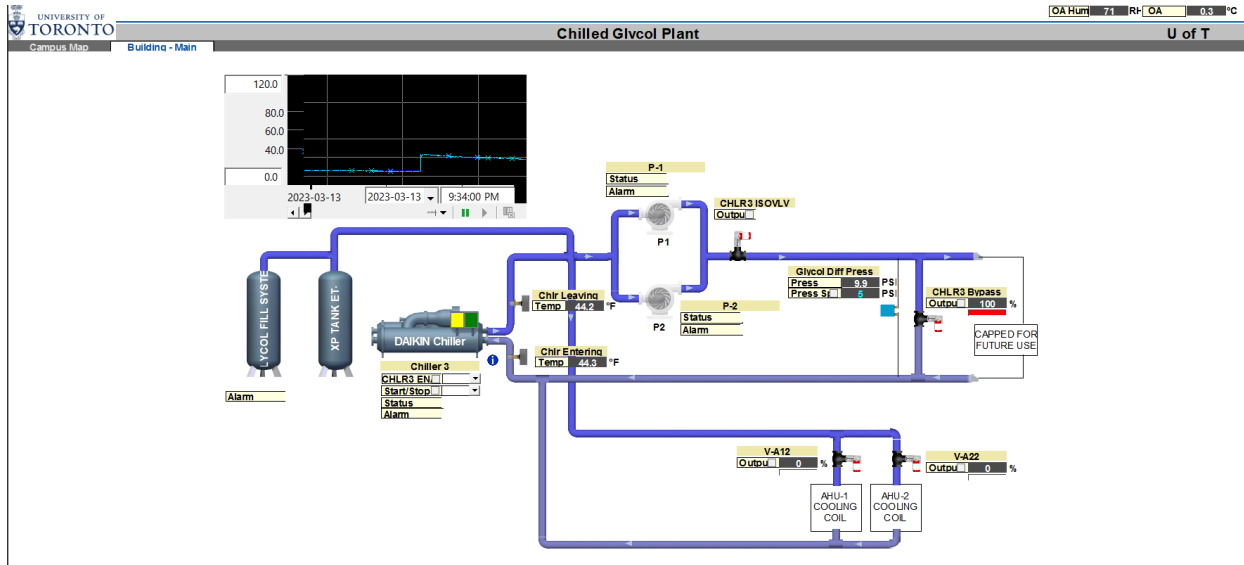

Figure 7 Penthouse Mech room (2017 Project) Chilled Glycol System

2.2.1.1 Peak demand and baseload

Based on the Steam utility bills, the peak monthly steam consumption was 2,705,000 lbs for the month of January, 2019 and 3,447,600 lbs for the month of January, 2018. An approximate peak consumption before the 2017 renovations was 7,000,000 BTU/hr. Based on trend data, the peak steam demand from November 2018 to February 2019 was 6,000 lbs/hr.

Based on a steam condensate study from November, 2018, the incoming steam main has a maximum capacity of 15,000 lbs/hr at 90 psi and 20,000 lbs/hr at 125psi, and the condensate line has a max capacity of 200 GPM with a minimum return temperature of 180F and above.

A regression analysis of the baseline year revealed a monthly baseload of 1,084 MMBTU, and is estimated to account for about 40% of the total steam load. Process load is estimated to account for about 77% of the baseload (~770 MMBTU/month) and DHW about 23% of the baseload. The low R² may be caused by the process loads skewing the analysis and a more detailed analysis may be required in the next phase of the project.

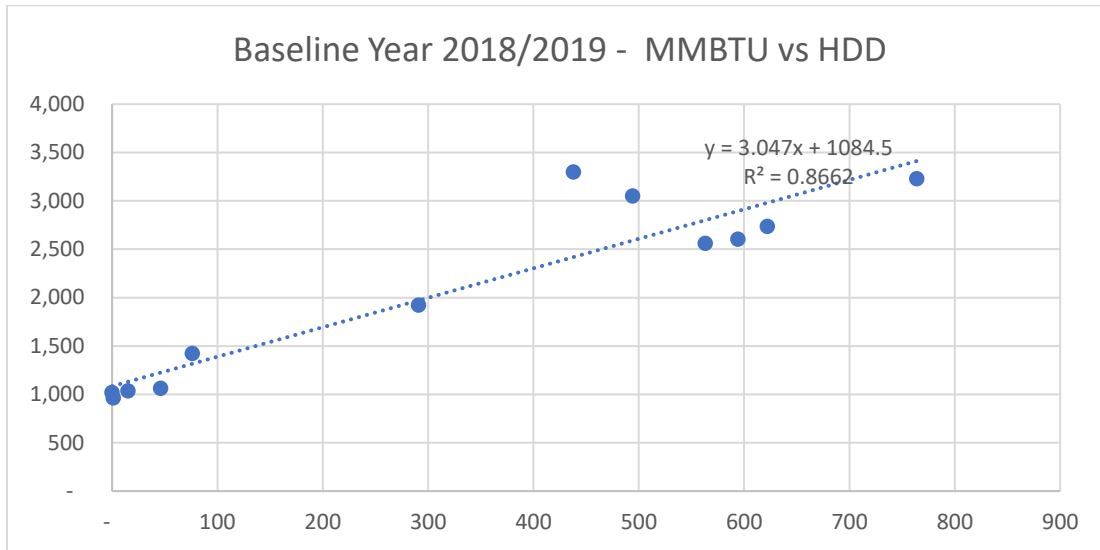

Figure 8 Monthly steam consumption regression analysis for baseline year

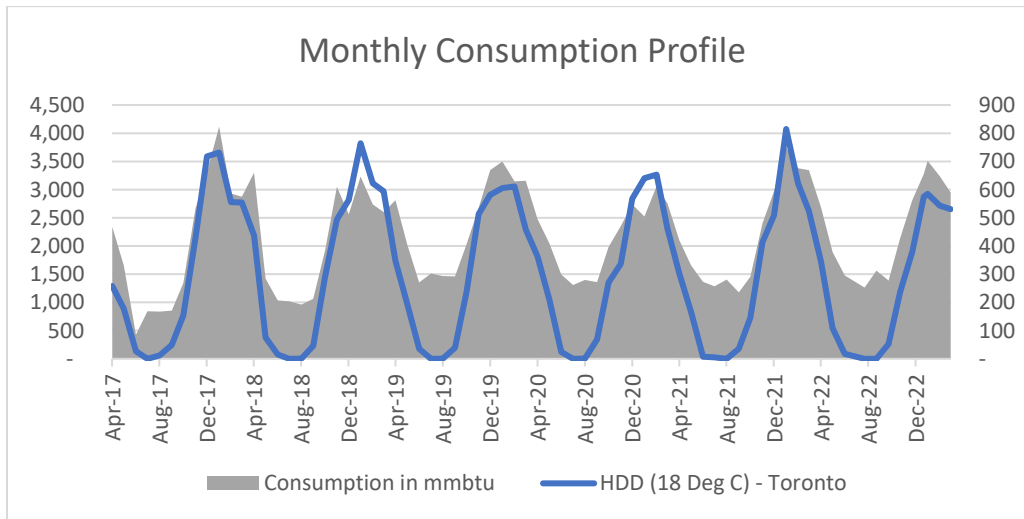

Figure 9 6-year total heating loads consumption profile

2.2.2 Ventilation

There are 22 active AHUs serving different zones in the building. The wet labs on the 4th and 5th floors are served by two new 100% OA, 20,000 CFM each. In addition, mechanical room 14 cooling is served by a dedicated 100% OA, 9,000 CFM AHU. All other AHUs run on a mixed air setting of 10-30% for most AHUs examined including the clinics' AHUs. Some AHUs do not have complete data, and one of the larger AHUs, AHU-21 was found to be running at 65% OA at the time of an air audit. A summary of the available AHUs available design data and air audit data are compiled in Appendix A.



New AHU 1 and 2 serving the labs, and AHU 21 are served by the new glycol heat exchanger in the penthouse mechanical room and receive a glycol mixture at ~ 140 Degf peaking at 147 Degf (Based on EMRS data in winter 2023 – while design temps are 180/160 Degf at OA<-4 Degf). All other AHUs are served by the glycol heat exchanger pair in the 5th floor mechanical room and receive glycol at ~ 145 Degf (Based on CCMS system data in Dec. 2022).

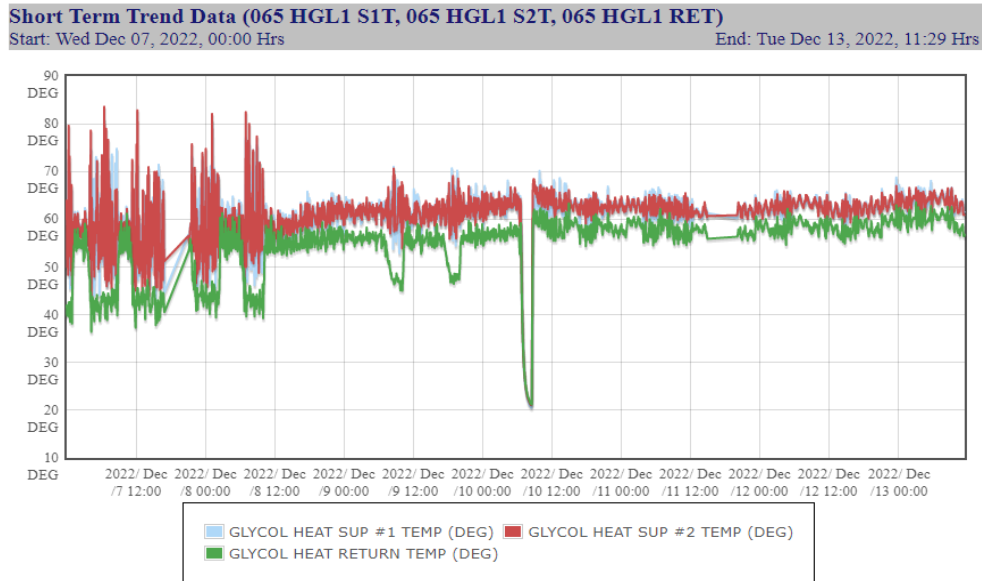

Figure 10 5-day analysis of Fifth floor Glycol system from CCMS (Pneumatic control system)

New AHUs 1 and 2 serving the labs and AHU 21 receive clean steam from a new clean steam generator in the penthouse mechanical room for humidification. All other AHUs use steam directly for humidification and the humidifiers examined were found non-operational.

New AHUs 1 and 2 serving the labs receive chilled glycol mixture from the new 200 Ton air cooled chiller located on the roof, with access valves to the main chiller plant in the basement. All other AHUs that are equipped with a cooling coil receive chilled water from the main chiller plant – 2 x250 Ton water cooled chillers in basement mechanical room 24.

Lab 4 ongoing renovation project will add a new AHU/HRV on the second floor roof that replaces the old AHU-3 which was demolished in 2022.

Appendix A details the specs of the AHUs.

2.2.3 Building Automation

The building currently has a combination of a legacy building automation system original to the building (CCMS) and a newer Siemens BAS for the recent renovation of the 4th and 5th floor in 2017. In addition to a dedicated system – Automated Logic Controls - controlling the 2x250 ton water-cooled chillers.



The legacy BAS system is a pneumatic system and was mainly for controlling air handling units, the basement chillers, and heating systems that are original to the building from 1958 and from the 1982 expansion.

The new Siemens BAS controls the new mechanical equipment that was part of the 4th and 5th floor renovation, which includes air handling units, air-cooled chiller, perimeter heating, lab exhaust, other exhaust fans, Mech room 14 AHU and fan coil unit, reception AHU, and labs VAV boxes. This Siemens BAS is also integrated into the University's Honeywell EMRS front-end system.

2.3 Medical & Dental Gas Systems

There are three compressors each approximately 200 scfm and 50 HP and 4 dental vacuum system located in the basement mechanical room 14. Two air compressors are oil free and one is lubricated with oil removal filtration which is used as backup. The dental vacuum system serves clinics 1 and 2, which have approximately 275 dental chairs, lab 4 with approximately 120 chairs, and a dry system that serves a clinic on level 2. The dental vacuum system utilizes mercury separators to capture amalgam and consists of four 22" Hg pumps @ 350 scfm that were installed in 2018.

2.4 Process Loads

The building labs and clinics use Autoclaves and glass wash units for equipment sterilization. The steam autoclaves in the building were located in various locations across the building prior to the Medical Device Reprocessing (MDR) project. MDR Autoclaves are electric. Currently, only 2 steam Autoclaves located in the 4th and 5th floors are expected to continue operating, however, several of the original steam Autoclaves still operate as backup units and for student's research. The MDR project scope included installing 3 electric autoclaves, however, the steam base load did not decrease and saw an increase in 2022/2023 school year indicating that several steam Autoclaves are still running on a full day schedule and/or the presence of a system leak. The electric load is expected to increase as well as base load as the MDR project becomes fully commissioned.

2.5 Electrical system

The switchgear bus is a 3000 A 346/600V split bus fed from two parallel 2000 KVA transformers that run at a maximum of 50% capacity to maintain redundancy, for maintenance purposes and to mitigate equipment failure events.

The existing 120/208V switchgear was installed when the building was built in 1958. Currently, the existing 120/208V switchgear is served from two parallel 600-120/208V transformers. The 600-120/208V transformers were installed in the 1980s when the building was upgraded from 120/208V to 13.8kV. The 120/208V transformers will be replaced with new dry type transformers as part of lab4 renovation.

The lighting system is a mixture of fluorescent and incandescent lighting from the basement level to the third floor. Lighting controls for this area is line voltage switching only, no automatic controls have been installed. Lighting with LED sources with Lutron control system have been installed on the fourth and fifth floors as part of the 2017 lab renovation project.



Emergency lighting for the basement to third floor uses a contactor to energize separate emergency lights that are normally off (similar to battery heads). The fourth and fifth floors use an automatic sensing device to switch selected lights to emergency power.

2.5.1.1 Peak Load and baseload

The building demand peaks at 1300 KW in the summer at peak cooling load of 650 KW and has a base load of 650KW (2018-2019 baseline year). The monthly baseload was 380,130 KWH in the baseline year.

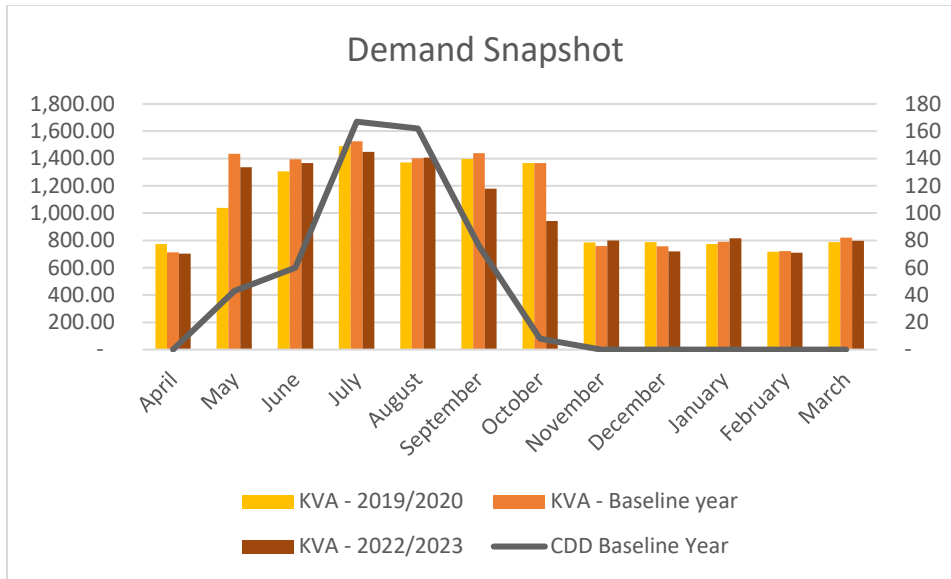

Figure 11 Electrical Demand Profile

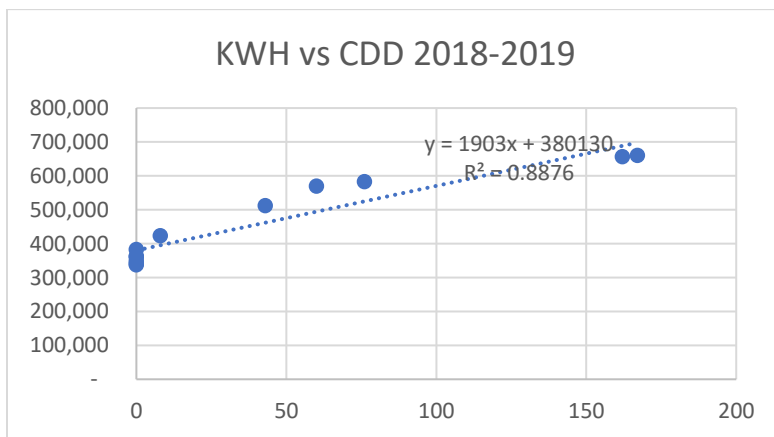

Figure 12 Monthly Electrical consumption Regression Analysis

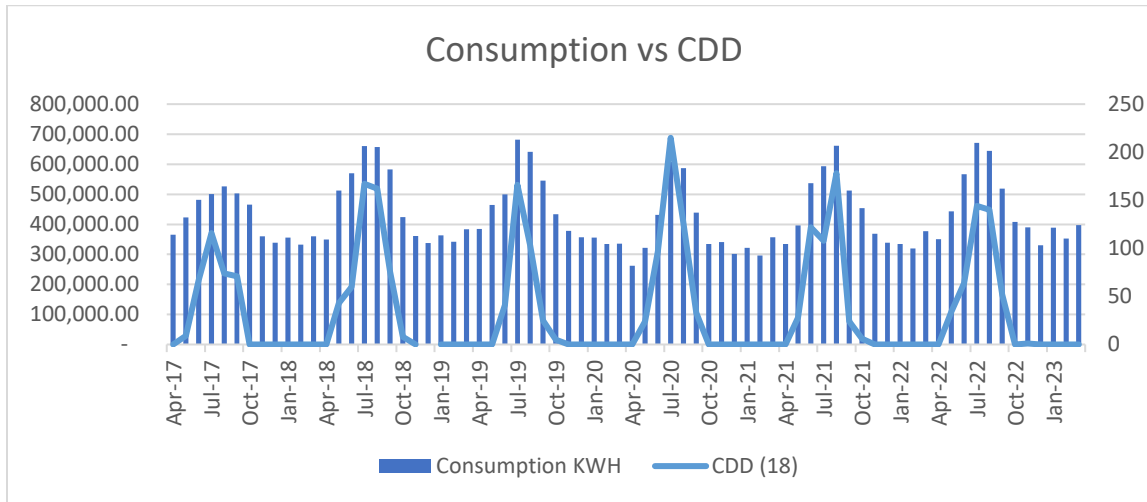

Figure 13 6-year Electrical Consumption Profile

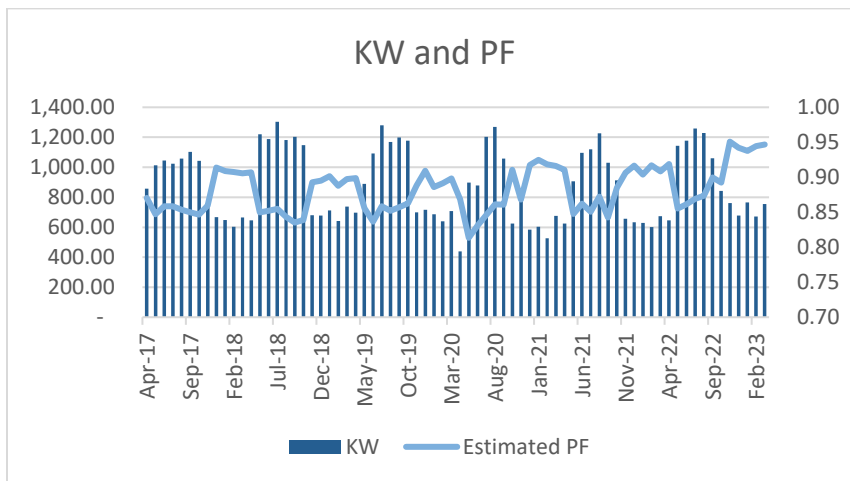
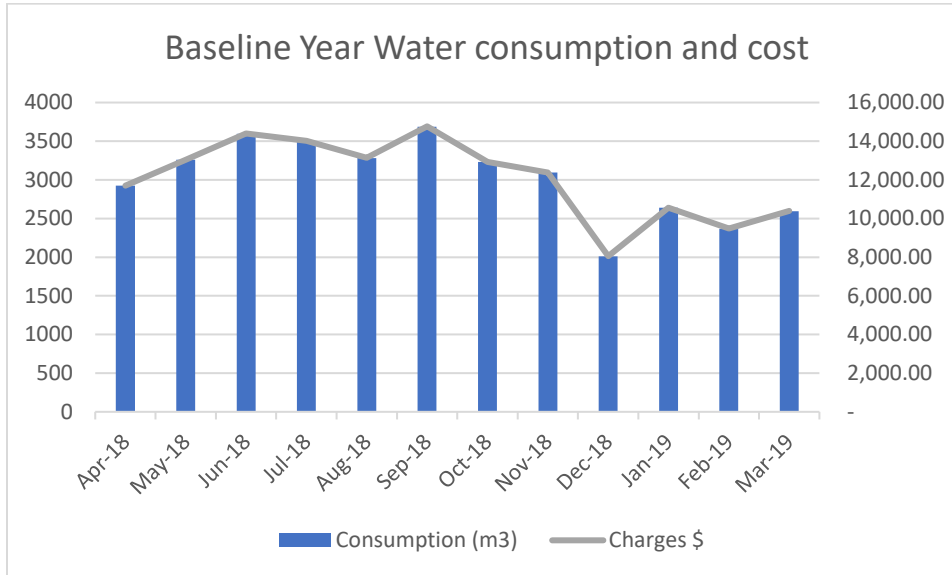

Figure 14 6-Year Power Factor Profile



2.6 Water Consumption



3.0 BUILDING PERFORMANCE ANALYSIS

A 3-year analysis of utility data was conducted and the year April 2018 to March 2019 was selected as a representative pre-covid and labs - 4th and 5th floor post renovation 2017 commissioning year.

Electrical Loads:

To achieve a representative energy end use breakdown, electrical meters were used to separate the mechanical loads from other plug loads and lighting.

Electrical meters used:

MCC2 (Air compressors and Oral Vacuums), MCC-8 (600 V mechanical loads), Splitter 3 (VFD Fan loads – S7,R7, S16,R16,S17,R17), DPAA (Misc. pumps), Chiller1, Chiller2, and Chiller3.

The above meters data were used to feed an eQuest model run as part of a Savings by Design workshop that was conducted by SBC and completed in October 2022.

The vacuum pumps and compressors values were based on MCC-2 meter data for the baseline year, however it seems to be low considering that the air compressors run all day at near full capacity with over 100 HP of air compressors alone excluding the dental vacuum pumps capacity that would apply during clinics operation.



The SBD workshop model was used to confirm some of the electrical loads that were not metered fully, mainly plug loads, total pump load, total fan loads and lighting.

Thermal loads:

To achieve a representative energy breakdown an estimate of:

- Humidification, based on available coil design data, EMRS inspection of typical humidification valve position of some of the connected AHUs, and feedback from building operations, and total estimated outside Air.
- Autoclaves process loads, based on equipment specs hourly capacity and schedule (applied to 5 Autoclaves to match 2018/2019 process load prior to MDR implementation)
- DHW load based on SBD eQuest model.

Energy End-use breakdown

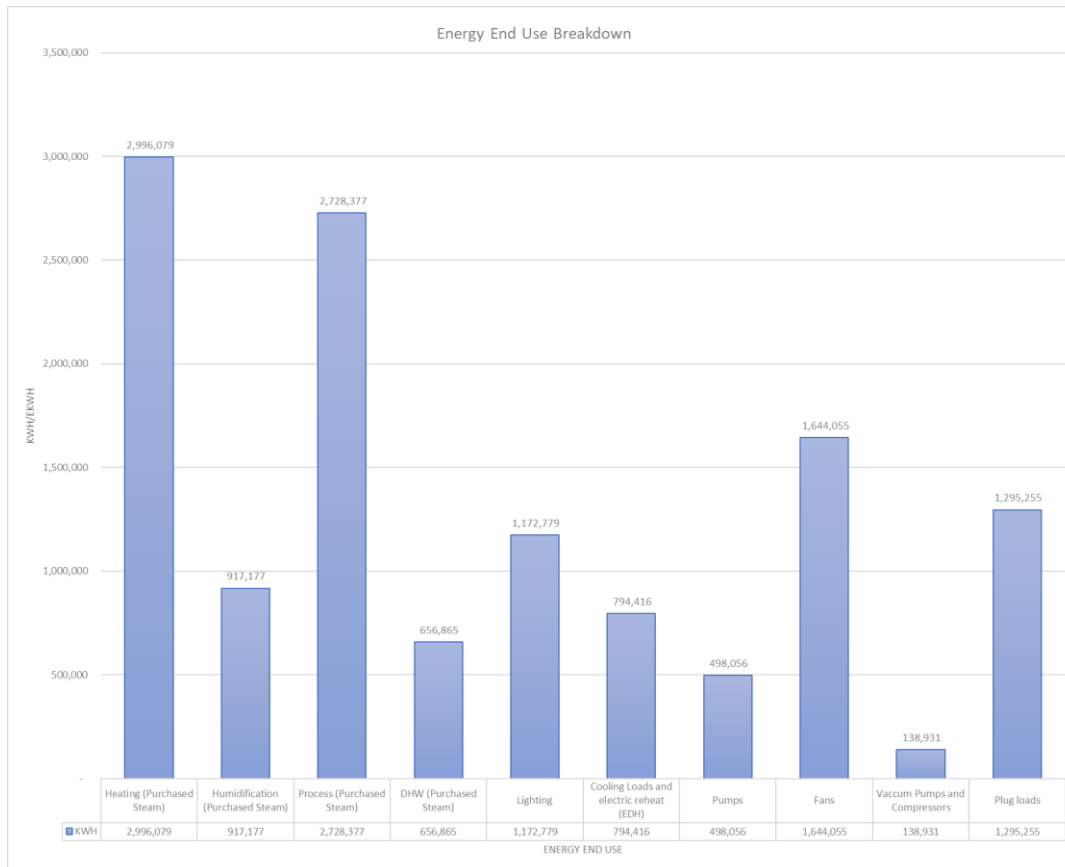

Figure 15 Thermal estimated energy end use breakdown



Performance metrics:

Dentistry Energy Metric	Units
TEUI (eKWH/m2)	523.49
TEDI (eKWH/m2)	213.38
GHGI (kg CO2e/m2)	74.63
GHG (Tons)	1,830.70

Table 3 Performance metrics

Rates Structure:

The Faculty of Dentistry (FOD) building is off the main campus and is fed by Toronto Hydro and Enbridge gas. Steam is supplied and delivered to the loads as hot water via steam to hot water heat exchangers, steam to glycol for AHUs heating and ramp heating, and used as steam for humidification, and process loads, with the exception of the new heating plant that uses a clean steam generator.

With reference to the rates table below, the gas rate has significantly increased in the second half of 2022 through the cost adjustment charge resulting in an average annual blended rate of just over \$0.58/m3. The blended rate includes the Federal carbon tax charge. Third party Steam unit rate has increased in the last quarter by 37% while the capacity charge increased by 6.4% bringing the expected average annual blended rate to \$27.3/MMBTU. The blended rate includes the Federal carbon tax charge. The blended average rate of electricity is \$0.132/KWH and the building is a class B customer with a peak of 1,304Kw in the baseline year and 1,260Kw in 2022.

The blended rates and capacity charges below were applied to the selected baseline year 2018-2019 fiscal year to estimate the utilities cost and savings after implementing the ECMs.

Emissions GHG values are estimated values for 2023.



Table 3: Rates Summary

Utilities Rates			Emissions	
Hydro Blended Rate	0.132	\$/Kwh	41	gCO2e/Kwh
kWh Rate	0.04	\$/Kwh		
kWh GA Rate	0.05	\$/Kwh		
Customer and Distribution (12 months-2022)	98,677.94	\$/year		
Transformer Allowance (12 months-2022)	- 7,579.44	\$/year		
Transmission Connection Charge per KW	2.27	\$/Kw		
Transmission Network Charge per KW	3.52	\$/Kw		
Regulatory per (12 months-2022)	22,275.55	\$		
Enbridge Gas Unit Rate	0.16	\$/m3	1,933	gCO2e/m3
Enbridge Gas Annual Fixed Charges	N/A	\$	182	gCO2e/ekwh
Enbridge Carbon Tax rate	0.09	\$/m3	53,326	g CO2e/MMBTU
Enbridge blended rate	0.58	\$/m3		
Enbridge Gas Unit Rate W/O Carbon cost	0.49	\$/m3		
Enbridge annual carbon escalation to 2030	0.03	\$/m3		
Steam Unit Rate	17.07	\$/MMBTU	76.6	g CO2e/lbs
Steam Annual Fixed Charges (baseline year)	168129.13	\$/year	220	gCO2e/ekwh
Steam Carbon Tax Rate	3.49	\$/MMBTU	64,370	g CO2e/MMBTU
Steam blended Rate	27.30	\$/MMBTU		
Steam Unit Rate W/O Carbon cost	23.82	\$/MMBTU		
Steam annual carbon estimated escalation to 2030	0.97	\$/MMBTU		
Water Rate	4.48	\$/m3		

Table 4 Utilities and emissions rates

Proposed Energy Conservation Measures Overview:

The primary challenge of decarbonizing the FOD building is that steam is used for 5 different applications – space heating, DHW heating, snow melting, humidification and process loads.

Dentistry Energy End Use	KWH	MMBTU	m3	%	Tons CO2	%	
Heating (Purchased Steam)	2,996,079	10,225.52			23%	658	35.95%
Heating (Gas)					0%	0	0.00%
Heating (Electrical)					0%	0	0.00%
Humidification (Purchased Steam)	917,177	3,130.30			7%	201	11.01%
Humidification (Gas)					0%	0	0.00%
Humidification (Electrical)					0%	0	0.00%
Process (Purchased Steam)	2,728,377	9,311.87			21%	599	32.74%
Process (Gas)					0%	0	0.00%
Process (Electrical)					0%	0	0.00%
DHW (Purchased Steam)	656,865	2,241.86			5%	144	7.88%
DHW (Gas)					0%	0	0.00%
DHW (electrical - HP)					0%	0	0.00%
Lighting	1,172,779				9%	48	2.63%
Cooling Loads and electric reheat (EDH)	794,416				6%	33	1.78%
Pumps	498,056				4%	20	1.12%
Fans	1,644,055				13%	67	3.68%
Vacuum Pumps and Compressors	138,931				1%	6	0.31%
Plug loads	1,295,255				10%	53	2.90%
Sum	12,841,990	24,910	-		100%	1831	100%

Table 5 Building Energy End use and carbon emissions summary



Energy End Use	eKWH	eKWH%	eKWH Savings	eKWH Savings (%)	CO2e (Tons) of proposed building	CO2e % of proposed building	CO2e Reduction (tons) from baseline	CO2e Reduction (%) from baseline
Heating (Purchased Steam)	-	0%	2,996,079	100%	0	0%	658	36%
Heating (Gas)	86,494	1%	- 86,494	-100%	16	5%	-16	-1%
Heating (Electrical)	985,005	13%	- 985,005	-100%	40	12%	-40	-2%
Humidification (Purchased Steam)	-	0%	917,177	100%	0	0%	201	11%
Humidification (Gas)	-	0%	-	0%	0	0%	0	0%
Humidification (Electrical)	917,177	12%	- 917,177	0%	38	11%	-38	-2%
Process (Purchased Steam)	-	0%	-	0%	0	0%	599	33%
Process (Gas)	-	0%	-	0%	0	0%	0	0%
Process (Electrical)	909,459	12%	- 909,459	0%	37	11%	-37	-2%
DHW (Purchased Steam)	-	0%	656,865	100%	0	0%	144	8%
DHW (Gas)	-	0%	-	0%	0	0%	0	0%
DHW (electrical - HP)	218,955	3%	- 218,955	0%	9	3%	-9	0%
Lighting	527,751	7%	645,028	55%	22	7%	26	1%
Cooling Loads and electric reheat (ED)	794,416	10%	-	0%	33	10%	0	0%
Pumps	498,056	6%	-	0%	20	6%	0	0%
Fans	1,315,244	17%	328,811	20%	54	16%	13	1%
Vaccum Pumps and Compressors	138,931	2%	-	0%	6	2%	0	0%
Plug loads	1,295,255	17%	-	0%	53	16%	0	0%
Sum	7,686,743	100%	5,155,248	40%	327	100%	1503	82%

Table 6 ECMs energy and carbon savings summary

The FOD building energy end use breakdown shows that heating is the highest energy load representing 23% of the total annual energy consumption. Space heating steam scope 2 emissions represent 658 tons or 36% of the building’s total emissions. The peaking gas plant proposed to supplement the heat pumps is estimated to add 16 tons of CO₂.

Humidification load represents 7% of the total energy load and 11% of the total carbon emissions or 201 tons annually. Addressing this load is typically using an electric boiler and that increases the electric load on the transformer significantly in the winter. The load here is estimated to be 450Kw for an electric boiler/clean steam generator. However, this may be underestimated since several of the AHU humidification units that are not connected to the new heating plant are not active as per building operations, artificially reducing the humidification load. Innovative, cost-effective solution to humidification will reduce the electrical load, reduce grid scope 2 emissions and increase savings.

Process loads for Autoclaves operation represent 21% of the total energy load and 32% of the total carbon emissions or 599 tons annually. This figure is based on pre-MDR addition and is expected to be still valid since the steam Autoclaves are still in service and the thermal load in 2022/2023 was slightly higher than the baseload year. Heat pump steam generators are proposed for process loads of the 4th and 5th floor lab Autoclaves.

Domestic Hot Water (DHW) load represents 5% of the total energy load and 8% of the total carbon emissions or 144 tons annually. This load is currently being supplied by a low-pressure instantaneous heat exchanger in mechanical room 14 and 2 high pressure supply tanks in mechanical room 24. Air source heat pump water heaters to feed both LP and HP water loops are being proposed to address this load.

Fans, lighting and plug loads are the top 3 electrical loads. Since plug loads are challenging to address, an ECM for a lighting retrofit and an ECM to address fan loads are proposed.



Lighting loads represent 9% of the total energy load and 2.7% of the total carbon emissions or 48 tons annually. The ECM proposed focuses on re-lamping rather than fixture replacement in addition to occupancy-based controls to keep the ECM economically viable.

Fan loads represent 13% of the total energy load and 2.9% of the total carbon emissions or 67 tons annually. A BAS system expansion ECM is proposed to address all critical AHU fans not equipped with VFD drives yet along with Demand Control Ventilation (DCV) using exhaust fans CO₂ sensors and dedicated ERV units for the bathrooms. Replacing dampers motors and fan blades with high efficiency fan blades are also part of this ECM. This measure will also see integrating the existing VFD controlled fans into a single system that is BACnet compatible. In addition, it will convert related pumps to VFD pumps where applicable and will integrate all newly added heating plant equipment. The new BAS system will integrate with the University's EMRS system. The impact of this measure on heating and cooling loads were not considered in this preliminary concept report and are expected to be included in an 8760-hour model.

Gas use is negligible and is not billed consistently. It has been omitted in this report due to lack of data.

4.0 BUILDING SYSTEMS DISCUSSION:

4.1 Building Mechanical systems:

Heating:

Perimeter heating capacity is supplied by Two steam to hot water shell and tube heat exchangers 1&2. The water is supplied at 180/160 DEGF

The Hot Water from the steam to water heat exchangers located in the basement mechanical room 14 feed all the perimeter radiators by supplying hot water to the perimeter heating pipe network.

A second pair of steam to hot water heat exchangers located in penthouse mechanical room fed from building steam feeds the VAV boxes in the lab floors. The temperature is supplied to this system at 160/140 DEGF.

Glycol heat exchangers supply the AHUs heating coils. A pair of steam to glycol heat exchangers is located in the 5th floor mechanical room and supplies glycol at 160/140 DegF. A second pair of steam to glycol heat exchangers located in the penthouse mechanical room fed from building steam, feeds the lab floors AHUs (AHU-1, 2) and the AHU-21. AHU-21 (AHU-21 used to have steam heating coils and was replaced with glycol coils as part of the lab floors retrofit). The glycol is supplied at 150/130 DegF based on BAS data while design temperatures are 160/140 DegF at OA temp above -5.8 DegF and 180/160 DegF below -5.8 DegF.

Domestic Hot water

High pressure DHW is supplied by 2 steam to hot water tanks in mech. room 24 at a temperature of 147 - 151 degf. Water is continuously circulated in the building using a recirc. Pump.



An instantaneous steam to hot water DHW heat exchanger in mech room 14 replaced the low pressure DHW tank in 2020 and supplies low pressure DHW at a temperature of ~140 degf.

Humidification

Humidification to the lab floors AHUs and AHU-21 is supplied through a clean steam generator located in the penthouse mech. room. The remaining AHUs seem to have no active humidification and are designed to use building steam directly.

Ramp Heating

Ramp heating is supplied by a steam to glycol heat exchanger located in the mech room 24.

Process Autoclaves

Prior to 2022 MDR project implementation to centralize the sterilization facility, several steam supplied autoclaves were active in different locations in the building. Currently, MDR has 3 electric autoclaves, and each lab floor has a new steam autoclave. The rest are expected to be decommissioned in the future. Two steam autoclaves (A4 and A5) are being used as backup currently in room 212 and both run on steam. They both run from 8:45am to 3:30pm.

The two Autoclaves serving the labs on floors 4 and 5 specs indicate ~ 250lb/hr of steam requirement per cycle, and they run for approx. 6 hours a day on weekdays.

4.2 Building Electrical system:

The building is hydro connected and served by a 13.8 KV service feeding 2 x 2,000 KVA – transformers 1A and 1B (13.8KV to 347/600V) transformers. The Main switchboard is a 3,000 A 3phase split bus. The primary transformers and bus serve a pair of secondary 600 KVA (600V to 208/120V) transformers. The secondary transformers feed a secondary 3,200A split bus (based on proposed renovation as per exp SLD E5-04 dated 22-09-22). The secondary transformers and switchgear are being replaced as part of Lab4 renovation scope.

Primary T2 transformer and bus serve mainly MCC#2, Splitter #3 (in AHUs room 547) and one of the primary water-cooled chillers - splitter #1. In addition, it serves one of the downstream secondary transformers that feed the 3,200A split bus. The secondary transformer feeds a parking garage bus as well as MCC#1, MCC#2, lab #4 loads, and one spare.

Primary T1 transformer and bus serve the planned lab 4 HRV and humidifier, Lab4 Heat pumps, one of the primary water-cooled chillers - splitter #2, Chiller #3 (200T air cooled chiller), MCC#8, Fire pump, emergency generator and life safety loads, AHU-4 (fume hood exhaust). In addition, it serves one of the downstream secondary transformers which primarily feed the building's riser loads via a 2,500A breaker.

Emergency power is provided through a 300KW generator that feeds a 400A 347/600V bus.

Projected peak load after proposed ECMs and Lab 4 implementation

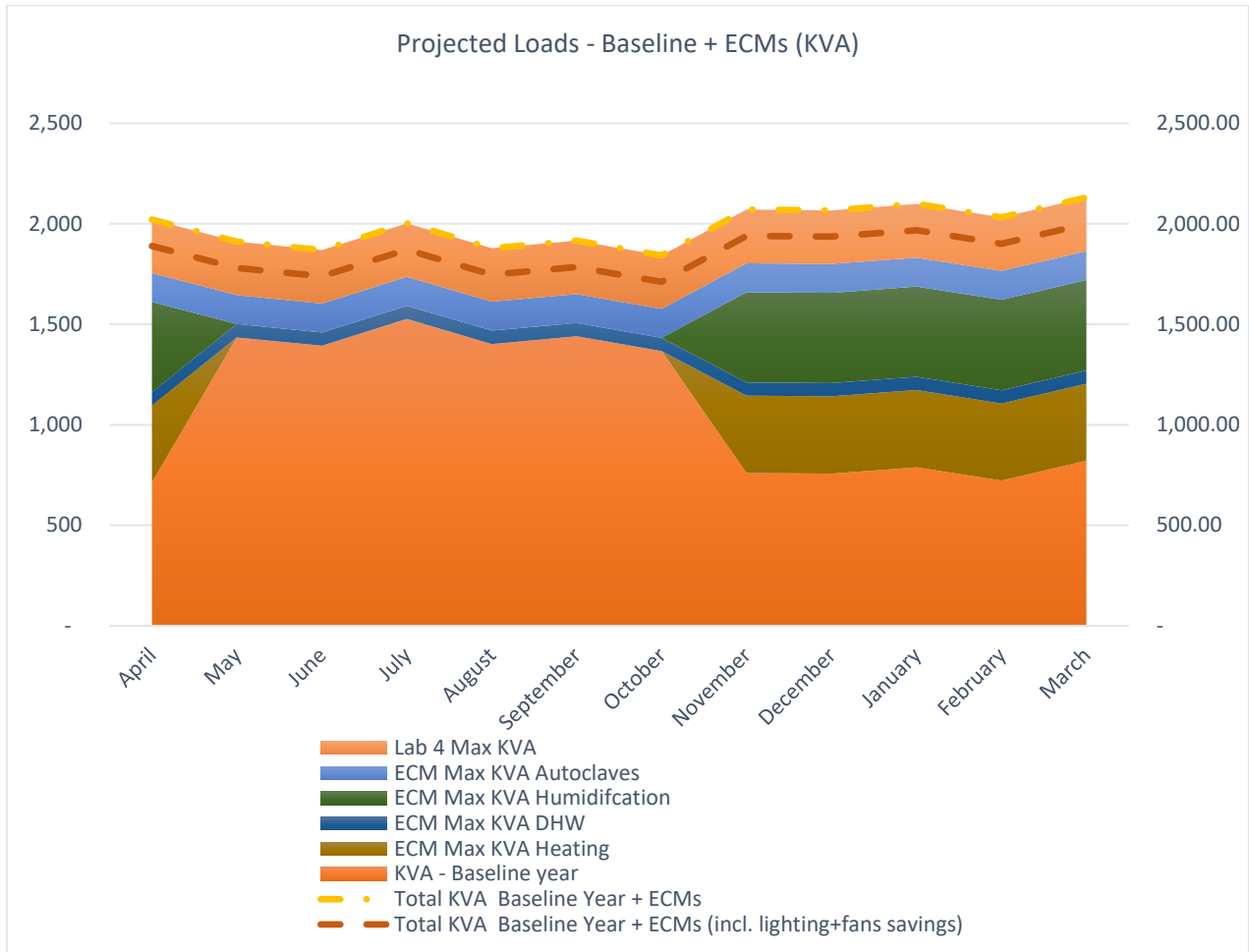

Figure 16 Projected Electrical load after implementing proposed ECMs – Baseline year simulation

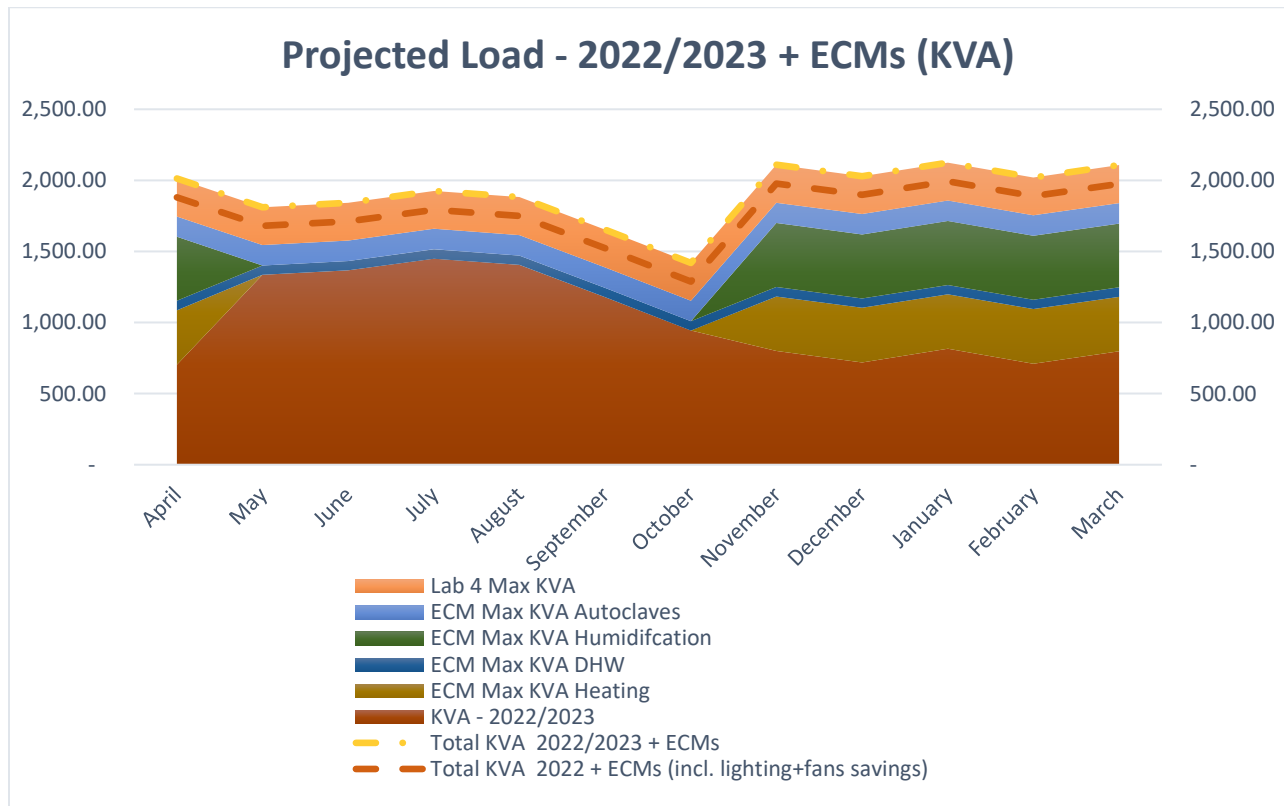

Figure 17 Projected Electrical load after implementing proposed ECMs – 2022/2023 fiscal year simulation

4.3 References

The information used to develop our understanding of the existing system is as follows:

1. FOD Clinical Renewal Master Plan Design Concept – 08 January 2020
2. School of Dentistry Drawings by Allward & Gouinlock and R.P. Allsop – 20 January 1958
 - a. Mechanical drawings M1 to M16
3. FOD Additions and Alterations drawings by Allward & Gouinlock – 19 August 1982
 - a. Mechanical drawings M1 to M36
4. Faculty of Dentistry Wet Lab Revitalization P065-16-069 by Stantec
 - a. Mechanical drawings M201-203, M300 – M302, and M400-403 - 13 March 2017
 - b. Electrical drawings E302-303 – 21-Sep- 2017
5. University of Toronto Superintendents office Diagram of Hot Water Heating Main – May 1962
 - a. 65M-20 to 65M-24
6. Wet Lab Revitalization (4th & 5th Floors) Control Manual by Siemens
 - a. As build drawings 201 to 251A, 301, 301A, 301B, 401, 401A, 401B, 402, 402A, 402B
7. U of T Dentistry – Air Compressor Exhaust System by Dunford-Liscio (Ontario) inc.19-March-2021



- a. As Build mechanical drawing M1
8. Enviro Balance Inc. Air Audit Report – 19 June 2020
9. Enviro Balance Inc. Air Audit Report – 8 June 2021
10. Dentistry VFA Deferred Maintenance Requirement Detail Report – March 2019
11. University of Toronto EM team Site visit performed on November 17, 2022

5.0 DETAILED PROPOSED ENERGY CONSERVATION MEASURES:

5.1 ECM-01A Heating Plant Electrification

This Energy Conservation measure aims to replace the heating plant currently running on third party steam with 300 Tons of water-to-water heat pump capacity. The proposed capacity will provide the building's total heating requirements to a temperature of -10 DegC or 3.2 MMBTU/HR. At temperatures lower than -10 DEGC (>3.2 MMBTU/HR), Two 3000 MBH gas fired high efficiency boilers will provide heating above 3.2 MMBTU/HR up to the maximum estimated space heating load of the baseline year 2018/2019 of 3.97 MMBTU/HR for space heating and up to an estimated ~5.36 MMBTU/HR combined loads - heating, humidification, process, and ramp heating. Annually this translates to Heat pump coverage of over 94% of the total building annual space heating demand. The remaining building demand will be provided by the peaking/backup high efficiency gas boilers. This 94% electrification of the space heating plant will result in a net of 658 tCO₂e or 36% of the total building CO₂e emissions. The above is based on the baseline year hourly heating load results derived from an hourly regression analysis plot. Assumptions were made to estimate the humidification, DHW and process loads as detailed in the previous sections.

Ramp heating was included as part of the space heating load demand above.

The proposed water-to-water heat pump plant concept is based on mechanically cooling ~85,000 CFM of conditioned air volume. This volume of air will comprise of exhaust air of the larger AHUs, 100% OA AHUs exhaust, and exhaust air of dedicated large exhaust fans such as mechanical rooms and transformer room fans. In addition, mechanically cooling return air where applicable such as office spaces AHUs that are equipped with cooling coils only. The proposed mechanical cooling strategy will diminish air side free cooling in favor of mechanical cooling. All rejected heat will feed the heat recovery hydronic loop.

Where exhaust air is available, new heat recovery cooling coils will feed the evaporator loop of the heat pump plant and will extract latent and sensible heat from the exhaust air by operating at large Delta T (close to sub-freezing mark).

Where an opportunity is available to replace free side air cooling with mechanical cooling to feed the heat pump evaporator loop, only sensible heat recovery was considered.

The terminal units – VAVs, perimeter heating Radiators, AHU heating coils, and Radiant Ceiling Panels are assumed to be effective for 94% of the time when run on low temperature hot water. However, testing will be required to validate this assumption. Outside of this window, the gas backup will provide higher temperatures water to operate at design efficiency/heat output.



In order for this ECM to be economically viable, the solution is focused on using the existing hot water pipe network to feed the existing terminal units with LTHW, and reducing the required new heat recovery coils CHW pipe run lengths as much as reasonably achievable.

A high-level conceptual schematic in appendix C highlights this approach.

Terminal Unit	Supply Temp (Design) (Degf)	Return Temp (Design) (Degf)	Existing condition	Proposed
VAVs on 4 th and 5 th Floor	160	140	HW – Steam to HW HX 1 – penthouse Mech room	-LTHW - Backup boilers
Perimeter heating Radiators – 1 st to 3 rd floor Radiant Ceiling Panels – 4 th and 5 th floor	180	160 (2023 trend data for 1 st to 3 rd floor Rads showed an average return temp. of 170 Deg)	HW - Steam to HW HX 1 and 2 – basement mech room 14	- LTHW or HW - Backup boilers
AHU heating coils – Non lab floors	160	140	Glycol - Steam to Glycol HX in fifth floor mech room	-LTHW to Glycol - Backup boilers
AHU heating coils – 4 th and 5 th floor lab floors	160	140	Glycol - Steam to Glycol HX in Penthouse mech room	-LTHW to Glycol - Backup boilers
Ramp Heating	-	-	Glycol - Steam to Glycol in mech room 24	-LTHW to Glycol - Backup boilers

Table 7 ECM 01 Parameters Summary



The heat pump plant is assumed to operate at an average COP of 3.0 in heating mode.

The chart below demonstrates the contribution of gas boiler trim to the heat pumps space heating coverage over the baseline year. Baseline year weather data calibrated to bills was used to estimate the heat pump and gas boiler trim breakdown. The breakdown was based on a heat pump cutoff at 3.2 MMBTU/hr load. Error between the hourly model and aggregated monthly bills was highest in the shoulder seasons and difference was assigned to the heat pumps. A more detailed hourly simulation with better definition of heating load is anticipated to reduce the error in this initial simulation and address the assumptions made.

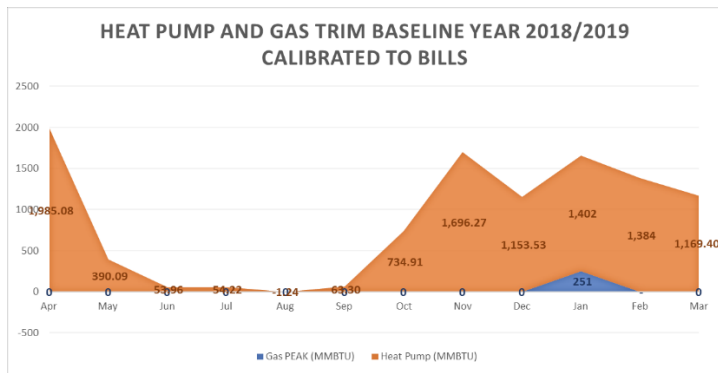

Figure 18 Heat pump and gas boiler demand

The diagram below outlines the locations proposed for installing the heat pumps and backup boilers.

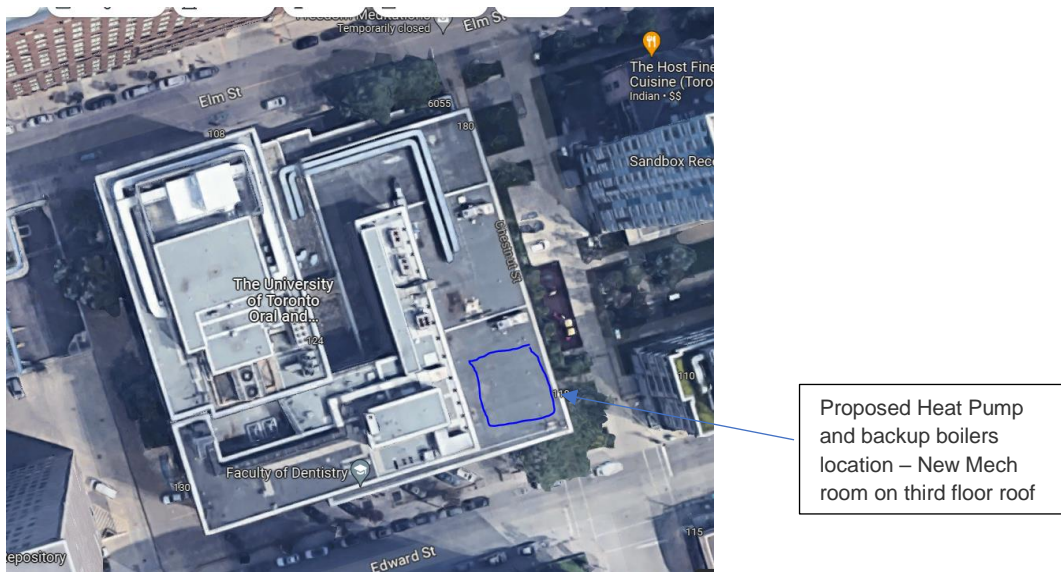

Figure 19 Option 1 - New Mech room for proposed heat plant

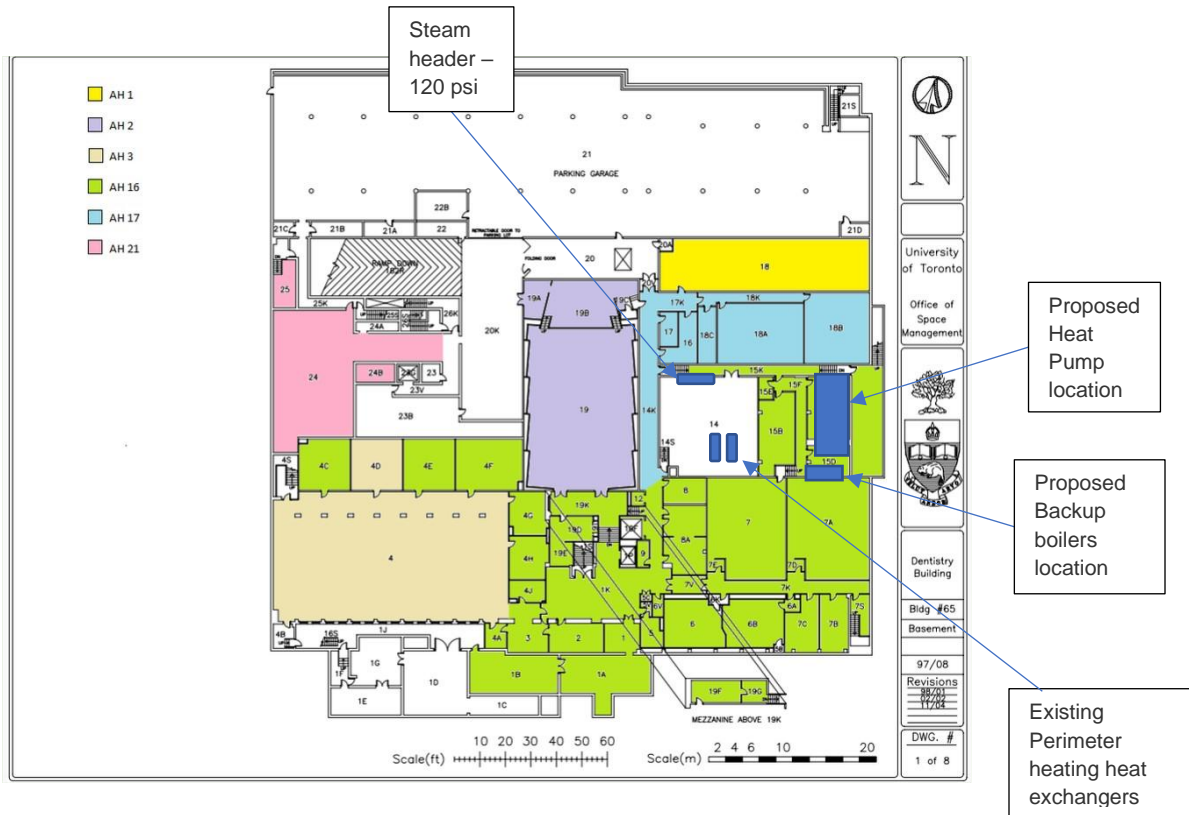

Figure 20 Option 2 - Partial heat pump capacity and backup boilers in room 15

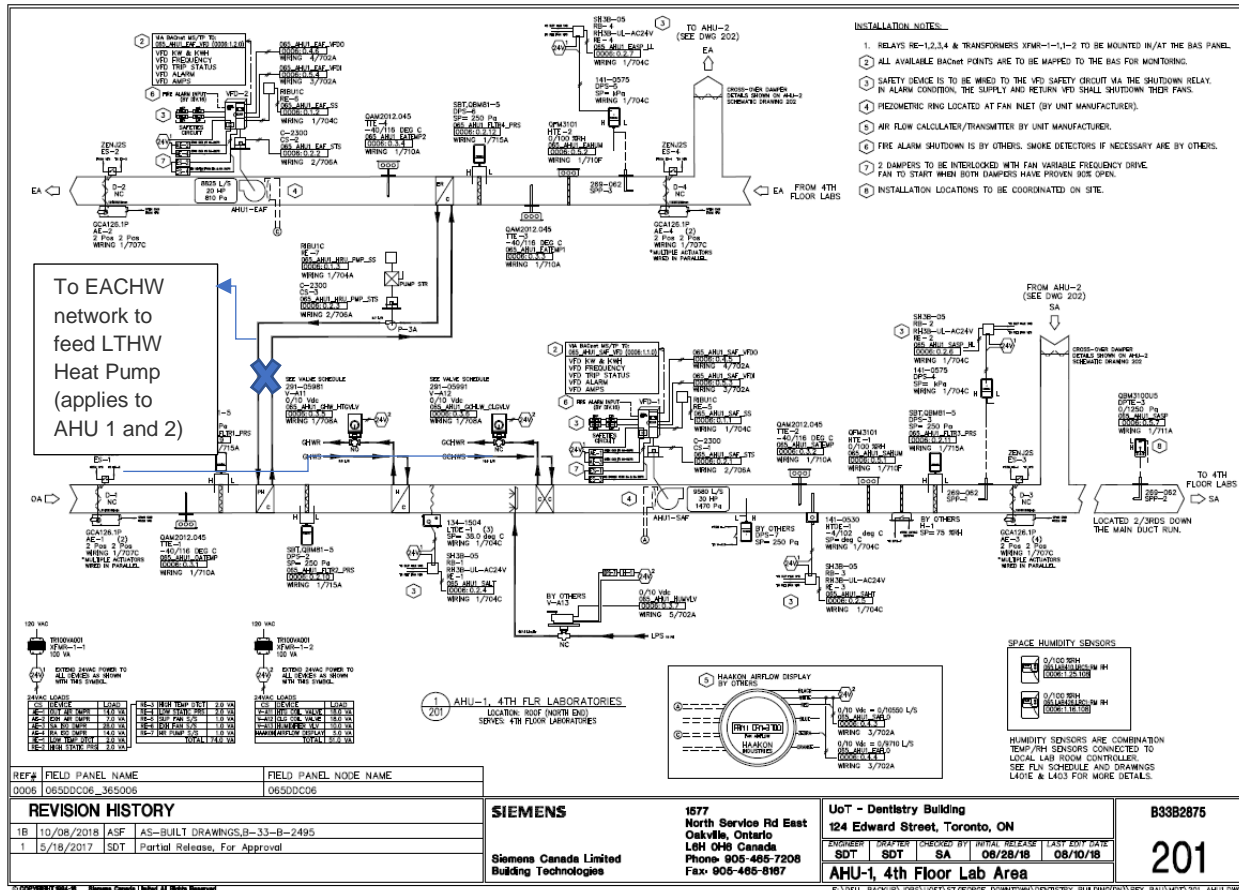

Figure 21 Proposed heat pump exhaust air heat recovery integration into the lab AHUs (AHU-1 and AHU-2)

Economics and assumptions

Assumptions:

- Space heating load and heat pump sizing based on high level hourly analysis only. Further investigation and modeling required.
- Water source Heat pumps running at a COP of 3.0 based on consistent temperature supply to the HPs
- Availability of sufficient exhaust air to chill to supply the rejected heat to the water source heat pumps
- Space availability

Constructability

The size, weight and space availability of the heat pumps pose the greatest concerns in addition to electrical capacity as discussed in the previous sections. In case of option 1 where a new mechanical room will be built on floor 3 roof, structural analysis is required. In addition, pipe routing will need to be selected so as not to disturb existing research, academic or clinic space. External piping will require UofT Architectural board review.



In case of option 2, the heat pumps may need to be modular to fit in the hallways leading to room 15. Another concern is approvals to assign the room as a mechanical room.

The construction will disrupt the heat supply especially in the final stage when connecting to the existing piping. The final stage of this measure’s construction will need to be off the heating season.

A communication plan will be developed to coordinate with building management.

5.2 ECM 01B – DHW electrification

This ECM proposes installing 50 tons of Air source heat pumps to electrify low pressure and high pressure DHW. Electrification of DHW will eliminate 8% of the total carbon produced or 144 tons annually. Air source heat pumps rather than Water source were selected based on the assumption that the building will not have sufficient simultaneous heating and cooling or exhaust air for heat recovery in the winter, to supply sufficient low-grade heat to the water source heat pumps to cover both DHW and space heating loads. However, this assumption will need to be validated when a detailed hourly simulation of heat demand is available.

High pressure DHW will require the addition of water tanks in room 24. The existing pumps could be used with the new heat pump and tank system. The proposed new heat pump system will feed the low-pressure DHW loop as well.

The system can be backed up by the backup boilers proposed for the heating loop trim and backup.

The Air source heat pumps proposed location is in the garage close to Mech room 24.

Terminal Unit	Supply Temp (DegF)	Current Source (DegF)	Proposed Source
Low pressure DHW	140 (CCMS data)	Steam to water instantaneous HX	Heat pump -Backup Boiler
High pressure DHW	Average ~147 (CCMS data)	Steam to water shell and tube HX	Heat Pump -Backup Boiler

Table 8 ECM 02 DHW parameters

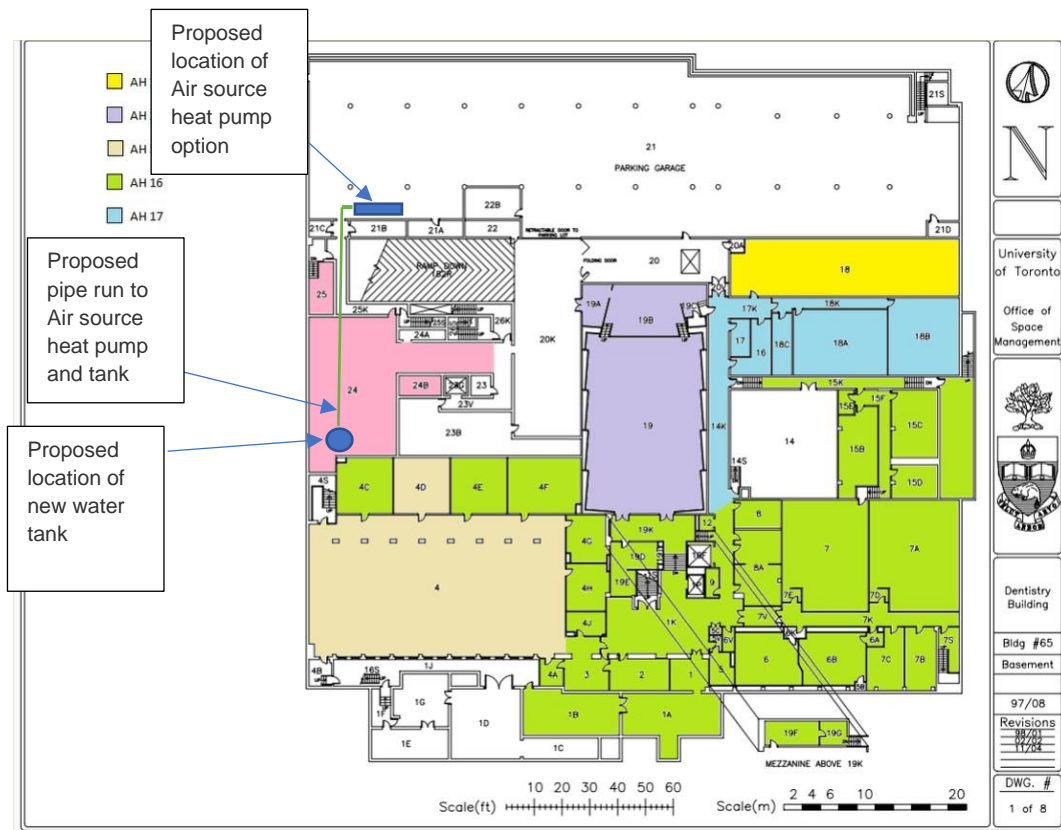
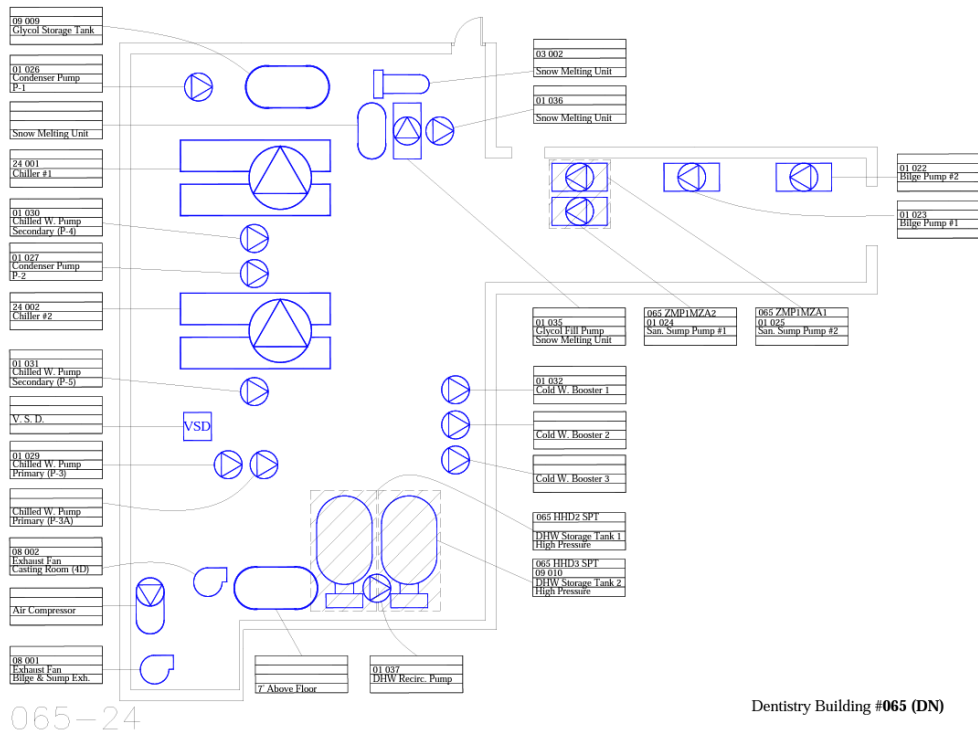

Figure 22 Proposed location of the DHW Heat Pump system



Dentistry Building #065 (DN)

Figure 23 Current layout of mechanical room 24

Economics and assumptions

DHW load is based on modeling and not actual measurements. Metering data or additional analysis is required to confirm load. Low flow faucets will be required as part of the project energy charter requirements and the corresponding reduction in DHW will need to be accounted for in the simulation.

Space allocation for Air source heat pumps in the garage and pipe runs to the low pressure and high-pressure pipe networks are based on assumptions of a clear location and path for pipe runs, and that sufficient space is available in mech. room 24 for new water tanks. These assumptions will need to be further investigated in the next phases of the project.

Constructability

The construction will disrupt DHW supply especially in the final stage when connecting to the existing piping and commissioning. The final stage of this measure's construction will need to be off the heating season.

We have assumed the installation work will be done during regular working hours or during low occupancy periods. We will create a detailed communication and delivery plan due to the nature of this installation, before work commences.



5.3 ECM 02 – Humidification electrification

This ECM electrifies the humidification load and will eliminate 201 tons of CO₂ annually. The electric steam boiler will have a capacity of 408 Kw.

Economics and assumptions

This capacity is based on a high-level estimate which does not include the fifth floor AHUs. As mentioned in the previous sections, the humidifiers for the fifth floor AHUs feeding floors 1 to 3, were found mostly inoperable. A study of the impact of lack of humidification in the 1st to 3rd floors is required to assess the need for a larger boiler and possibly a second low pressure clean steam generator to supply the fifth floor AHUs.

The steam boiler can be installed in the penthouse mechanical room or the new proposed Mech room on the third-floor roof.

Constructability

We have assumed the installation work will be done during regular working hours or during low occupancy periods. We will create a detailed communication and delivery plan due to the nature of this installation, before work commences.

5.4 ECM 03 – Autoclaves steam supply electrification

Process loads for Autoclaves operation represents 21% of the total energy load and ~33% of the total carbon emissions or 599 tons annually. This ECM proposes installing a heat pump steam generator to electrify the steam supply required for the Autoclaves on the 4th and 5th floors as well as the other Autoclaves that have not been decommissioned yet on floors 1 to 3.

Economics and assumptions

The heat pump steam generator capacity is based on pre-MDR addition. The Autoclaves steam demand is expected to be much lower in the coming years as the electric MDR Autoclaves are fully commissioned. The only steam depended process loads are expected to be the 2 Autoclaves on the lab floors, or ~30% of the baseline year process load referenced here. Process loads pre and post MDR will continue to be refined in collaboration with property management and MDR project manager.

The Heat pump steam generator is assumed to have the required LTHW supply required (120 DEGF) to operate efficiently. The additional LTHW required is assumed to be supplied by additional WSHP and recovering heat from the Autoclaves condensate or exhaust air.

Constructability

This retrofit will need to be planned so as to avoid disrupting the operation in the building.



We have assumed the installation work will be done during regular working hours or during low occupancy periods. We will create a detailed communication and delivery plan due to the nature of this installation, before work commences.

5.5 ECM 04 – Lighting Retrofit

A lighting retrofit is proposed to reduce the current LPD by about 55% using a combination of LEDs and lighting controls.

This retrofit is expected to save 645 MWH or 55% of the current 1,172 MW annual lighting load and will eliminate 26 tonnes of CO₂e annually.

The building is primarily fitted with 4ft and 8ft T8 32W two lamp fixtures. A type B retrofit is proposed controlled by occupancy sensors.

Economics and assumptions

Data is based on fixture type and count obtained from the deferred maintenance report, and visual inspection of key spaces. The actual count will require a more detailed lighting audit. The impact of lower lighting induced heat on winter heat demand was not accounted for.

Constructability

This retrofit will need to be planned so as to avoid disrupting the operation in the building.

We have assumed the installation work will be done during regular working hours or during low occupancy periods. We propose to install this measure in many areas of the facility including in academic areas so that requires careful coordination. We will create a detailed communication and delivery plan due to the nature of this installation, before work commences.

5.6 ECM 05 – Building Automation System (BAS)

Fan loads represent 13% of the total energy load and 2.9% of the total carbon emissions or 67 tons annually. A BAS ECM is proposed to address all critical AHU fans not equipped with VFD drives. Adding VFD drives, replacing faulty dampers and installing high efficiency fan blades are also part of this ECM. This ECM proposes implementing Demand Control Ventilation (DCV) using exhaust fans CO₂ sensors as a potential control strategy. The contemplated scope also includes dedicated bathroom ERVs. This measure will also see integrating the existing islanded VFD controlled fans into a single system that is BACnet compatible and complies with the University's controls standard. In addition, it will integrate proposed ECMs equipment, and integrating the existing two water-cooled chillers, pumps, and cooling tower. All control points are to be integrated into the University's EMRS platform.

The system will be programmed to allow for peaking/backup boilers activation for trimming/backup and will control all related valves, and pumps.

The high-level systems proposed for integration into the new BAS are estimated but not limited to the following:



- 12 existing AHUs – add minimum of 30 measurement and control points each (Budget dependent)
- New DCV for non-lab AHUs
- New CO2 Sensors for a minimum expected 22 exhaust ducts
- Existing chiller controls – integrate existing water-cooled chillers into the new BAS system
- Existing cooling tower – add a minimum of 10 measurement and control points
- New proposed peaking/backup boilers
- New Humidification boiler and clean steam generator
- New Autoclaves steam generator Heat Pumps/steam boiler
- New LTHW heating Heat Pumps
- Bathroom ERVs
- New DHW Heat Pumps
- Integration of existing AHUs VFDs
- Integration of lighting controls

Economics and assumptions

CCMS controlled equipment to be transitioned to the new BAS system with minimal disruption to the equipment operation, such as pumps and fans.

Constructability

We have assumed the installation work will be done during regular working hours or during low occupancy periods. We propose to install this measure in many areas of the facility including in academic areas so that requires careful coordination. We will create a detailed communication and delivery plan due to the nature of this installation, before work commences.

6.0 DEFERRED MAINTENANCE AND MAINTENANCE ITEMS NOT ADDRESSED IN THE PROPOSED ECMS PACKAGE:

6.1 Air ducts, windows and penetrations sealing

This item was identified through air audits and is considered a critical maintenance item that affects the building's energy efficiency. A total leak rate of 5.5 L/S was identified in modeling of the building which exceeds the university's standard.

Since the main ductwork in the main shaft is not accessible due to asbestos, sealing of the ductworks in the main shaft and sub shafts identified as leaking in the air audits is proposed rather than replacing the complete duct work. Aerosolized or other technology for duct sealing internally is proposed. Asbestos containment will be required during the sealing operation.

Caulking and sealing of window frames, ceiling and walls penetrations is also included in this item to reduce the air leakage rate. Refer to the Thermographic scan for identification of main leakage locations.

6.2 Exterior doors replacement

Exterior doors are a category 2, potentially critical DM item.

The scope of work includes the demolition and replacement of 19 exterior doors complete with frames.



6.3 2000 KVA primary transformer replacement

The Two primary 13.8KV to 600 V – 2000 KVA transformers have reached the end of life and are due for replacement. To ensure electrical capacity availability for future faculty renovation/expansion projects, it is recommended to replace the two transformers with 2500 KVA transformers. The higher capacity transformers will also ensure ability to operate safely if the proposed heating electrification measures efficiency (COP of heat pumps) drop below the design COP.

7.0 LOW CARBON ACTION PLAN

The addition of FOD retrofit to the U of T Low Carbon Action Plan (LCAP) will contribute 1500 tCO₂e reduction or avoidance at a tri-campus level by end of calendar 2026. This contribution supports the U of T in meeting or exceeding its 2030 commitments to mitigate the impacts of climate change thru a 37% GHG reduction relative to a 1990 baseline.



8.0 MANDATORY REQUIREMENTS

8.1 Outcomes / Performance Metrics

The following is a list of performance-based metrics:

- Minimum reduction of 80% of the candidate buildings annual scope 1 & 2 emissions and meet the Project Charter which specifies the Energy Use Intensity (“EUI”) target for each building. The (“Project Charter”) defines the energy targets for the projects. Sample Project Charters are found in Appendix D to this RFSQ.
- The utility budget (natural gas, fuel oil, electricity, and water), excluding carbon tax, remains the same or is reduced. Utility rates are fixed to the base year rates.
- Maximize the Net Present Value (“NPV”) using the U of T’s Lifecycle Cost Analysis (“LCCA”) template
- Maximize Greenhouse Gases (“GHG”) reduction
- Project life not to exceed 20 years
- Address Deferred Maintenance (“DM”) on a building-by-building basis
 - Dentistry: Min. requirement – Upgrade 2,000 KVA transformers to 2,500 KVA
- Perform conversions to low temperature hot water LTHW (<57°C) in support of our Carbon and Energy Master Plan to electrify and decarbonize our campus
- Provide updated as-built drawing sets for all buildings affected
- Provide complete Operations and Maintenance (“O&M”) manuals for full scope of the Project
- Provide comprehensive training on all systems to U of T staff
- Meet the requirements of the Tri-Campus Energy Modelling & Utility Performance Standard for all building retrofits as established by the Project Charters (see Appendix D for sample project charters)
- Comply with all applicable U of T standards including, but not limited to, Facilities & Services design, performance standards, and Environmental Health & Safety standards
- Ensure continuity of critical operations and research in laboratory facilities
- Address provisions for future expansion – of Clinic 2 second floor infill at Dentistry and additional floors at 255 McCaul
- Modernization and Integration of building the Building Automation System (“BAS”) into U of T’s Centralized Management and Reporting System (“EMRS”) portal

8.2 U of T Design Standards

All designs must be compliant with all U of T design standards unless exemptions are approved by the Project Steering Committee.

The latest U of T Design Standards are located here:

<https://www.fs.utoronto.ca/projects/design-standards-and-project-forms/>

<https://ehs.utoronto.ca/resources/standards/>

These shall include but are not limited to



- Mechanical Design Standard
- Electrical Standards
- Building Commissioning Design Standard
- Building Automation System Design Standard
- Fume Hoods & Fume Hood Exhausts Standard
- Laboratory Design Standard and Guidelines



9.0 FINANCIAL ANALYSIS

Omitted.



APPENDIX A – AHU (AIR HANDLING UNITS) SUMMARY



Seq.	AHU #	Air Supply	VFD	Heating coil(s) - Design Data	Cooling coil(s) - Design Data	Humidification Supply	Supply Air Fan - Design Data	Return Air Fan - Design Data	Zones Served	Remarks
1	AHU 1 old	Mixed	No	S1 50% EG EAT: 13 DEGC LAT: 21 DEGC Flow Rate: 1,421 L/S EWT:71 DEGC LWT:60 DEGC Flow Rate: 0.35 L/S	S1 CHW EAT: 26.2 DEGC DB/19.3 DEGC WB LAT: 12.8 DEGC DB/11.4 DEGC WB Flow Rate: 1,421 L/S EWT: 5.5 DEGC LWT: 13.8 DEGC Flow Rate: 1.09 L/S	Unknown Assumed inoperable			Book and basement storage room 18	1983 fan and coil design data presented where available Site visit Mar 2023 manual Calcs: 51% OA Min 10% OA
2	AHU 2 old	Mixed	No	S2 50% EG EAT: 13 DEGC LAT: 21 DEGC Flow Rate: 4680 L/S EWT: 71 DEGC LWT: 60 DEGC Flow Rate: 1.17 L/S	S2 CHW EAT: 26.2 DEGC DB/19.3 DEGC WB LAT: 12.8 DEGC DB/11.4 DEGC WB Flow Rate: 4680 L/S EWT: 5.5 DEGC LWT: 13.8 DEGC Flow Rate: 3.58 L/S	Unknown Assumed inoperable	4,649 L/S (9,850 CFM)	4580 L/S (9700 CFM @1635 RPM) 7.5 HP 0.75" WG	Lecture Hall room 19 (Auditorium)	1983 fan and coil design data presented where available Min. 10% OA Enviro Audit June 2020: 4447 L/S (9422 CFM) measured at fan inlet (100% OA) Site visit Mar 2023 Calcs: 22% OA Return Fan: Enviro Audit June 2020: 3035 L/S (6430 CFM)



3	AHU 1 new	100% OA	Yes	50% Propylene Glycol (425 KW) From Penthouse mech. Room glycol HX EAT: -23 DEGC LAT: Flow Rate: 9580 L/S Outdoor Air: 9580 L/S EWT: 82 DEGC LWT: 71 DEGC Flow Rate: 9.15 L/S	Chilled Glycol (352 KW, sensible 187KW) From roof Air Cooled Chiller EAT: 32 DB/24 WB DEGC LAT: Flow Rate: 9580 L/S Outdoor Air: 9580 L/S EWT: 7.2 DEGC LWT: 12.8 DEGC Flow Rate: 9.15 L/S	Fed from Clean Steam Generator (CSG) 161 KG/Hr	9,580 L/S (20,300 CFM) AHU1-SAF 30HP 750 pa	7,358L/S (15,590 CFM) AHU-EAF 20HP 750 pa	4th Floor Labs	coil and fan Data based on IFC drawings dates 2017 Glycol Supply Temp: 73 Degc (163 Degf) Glycol Return Temp: Penthouse steam to Glycol equipped with heat recovery coil Steam - Valve position found on EMRS at ~50% Terminal units are VAVs (HW from penthouse HX) and Radiant Ceiling Panels
4	AHU 2 new	100% OA	Yes	50% Propylene Glycol (425 KW) From Penthouse mech. Room glycol HX EAT: -23 DEGC LAT: DEGC Flow Rate: 9580 L/S Outdoor Air: 9580 L/S EWT: 82 DEGC	Chilled Glycol (352 KW, sensible 187KW) From roof Air Cooled Chiller EAT: 32 DB/24 WB DEGC LAT: Flow Rate: 9580 L/S Outdoor Air: 9580 L/S EWT: 7.2 DEGC LWT: 12.8 DEGC Flow Rate: 9.15 L/S	Fed from Clean Steam Generator (CSG) 161 KG/Hr	9,580 L/S (20,300 CFM) AHU1-SAF 30HP 750 pa	7,358L/S (15,590 CFM) AHU-EAF 20HP 750 pa	5th Floor Labs	coil and fan Data based on IFC drawings dated 2017 Glycol Supply Temp: 73 Degc (163 Degf) Glycol Return Temp: Penthouse steam to Glycol equipped with heat recovery coil Steam - Valve position found on EMRS at ~50% Terminal units are VAVs (HW from penthouse HX) and Radiant Ceiling Panels



				LWT: 71 DEGC Flow Rate: 9.15 L/S						
5	AHU 3 New	Mixed	Yes	N/A (Cooling coil only)	S3 (66 KW) CHW EAT: 32 DEGC DB/24 DEGC WB LAT: Flow Rate: 3,550 L/S EWT: 7.2 DEGC LWT: 12.8 DEGC Flow Rate: 2.45 L/S	6.8 KG/HR	3,553 L/S (7,115 CFM) 7.5 HP 250 pa	3,207 L/S (6,795 CFM) 3HP 250 pa	5th Floor office Area (South Wing) Active during office hours	coil and fan Data based on IFC drawings dated 2017 Terminal units are VAVs (HW from penthouse HX) and Radiant Ceiling Panels
6	HRV - AHU 3 replacem ent- Lab4	100% OA	Yes	HRV: Heat Pipe - Electrical Preheat - ASHP heating section (83 KW) 282 MBH Heat Pipe EAT: -20/-20 DEGC DB/WB LAT: -2.1/-2.6 DEGC DB/WB Electrical Pre- heating (37 KW) EAT: -2.1 DEGC LAT: 5 DEGC Heating ASHP	HRV: Heat Pipe - ASHP cooling (154 KW) - 526 MBH Heat Pipe EAT: 31/23 DEGC DB/WB LAT: -29.3/22.5 DEGC DB/WB Cooling ASHP EAT: 29.3/22.5 DEGC LAT: 12.7/12.7 DEGC Flow Rate: 4247 L/S	Electrical: 84 KG/HR - 61.7 KW	2 supply fans Total air flow: 4,245 L/S (9000 CFM) 9.38 HP (7KW) each fan VFD 697 pa each fan	Total air flow: 4,245 L/S (9000 CFM) 4.69 HP (3.5 KW) each VFD 398 pa each Fume Hood Exhaust Fan 707 L/S (~1500 CFM)	New pre-clinical Lab4 in the basement	Final Design specs reported - Construction phase starts in 2023/2024 Terminal units are VAVs with electrical reheat coils



				EAT: 5 DEGC LAT: 21 DEGC Flow Rate: 4247 L/S						
7	MDR AHU (replaces old AHU4)	Mixed	Yes	50% Propylene Glycol (201.7 KW) from existing fifth floor HX EAT: -20 DEGC LAT: 19.2 DEGC Flow Rate: 4247 L/S EWT: 54.4 DEGC LWT: 43.3 DEGC Flow Rate: 4.86 L/S	DX Coil (77.2 KW) EAT: 25.2 DEGC DB/18.2 DEGC WB LAT: 13.2 DEGC DB/12.9 DEGC WB Flow Rate: 4247 L/S	yes	2 supply fans Total air flow: 4,247 L/S 5.5 HP (4.1KW) each fan VFD 498 pa each fan	2 return fans Total air flow: 3,492 L/S 3 HP (2.2KW) each fan VFD 374 pa each fan	1st floor MDR sterilization facility (113)	Equipped with Enthalpy Wheel - >90% eff. Electric humidifier and hot water terminal reheat coils Design specifies ~30% OA TAB report April 2022: 3,465 L/S (7,342 CFM) Terminal units are VAVs (HW from basement HX) and Radiators
8	Labs Exhaust AHU4	Exhaust fans	Yes	N/A	N/A	N/A	N/A	Three LEF fans, 2 active constantly 10 HP each 2,398 L/S (5,081 CFM) each -500pa	Fume hoods exhaust - 4th and 5th floors	Two fans run 100% of the time



9	AHU 5	Mixed	No	Glycol 5th floor steam to Glycol (~73 DEGC - 163 DEGF)	DX Coil	Unknown Assumed inoperable			Pedo Clinic and Clinic 1 - rooms 133, 133S & 102	Min. req. is 30% OA Supply Fan: Enviro Auit June 2020: 5093 L/S (10791 CFM) 0% exhaust at time of audit/OA and return air 50% open March 2023 site visit calcs: 35% OA Return Fan: Enviro Auit June 2020: 4149 L/S (8791 CFM) 35% OA based on site visit (Apr 2023) CCMS RAT/MAT/OAT readings
10	AHU 7	Mixed	No	N/A	S7 CHW EAT: 26.2 DEGC DB/19.3 DEGC WB LAT: 12.8 DEGC DB/11.4 DEGC WB Flow Rate: 3,675 L/S EWT: 5.5 DEGC LWT: 13.8 DEGC Flow Rate: 2.81 L/S	Unknown Assumed inoperable	7.5 HP - Max 1750 RPM		Lecture Halls 170, 170 (A,B,C,D), 171, 171(A,B, S,D), 100H	1983 fan and coil design data presented where available Supply: Enviro Audit 2021: 5861 CFM @1101 RPM, 3554 CFM delivered to diffusers in rooms 170 and 171 Return: Enviro Audit 2021: Fan delivers 4130 CFM, 3007 CFM measured at return grilles, difference of 1123 CFM due to leaks



11	AHU 8	Mixed	No	S8 50% EG from existing fifth floor HX EAT: 10 DEGC LAT: 21 DEGC Flow Rate: 2,448 L/S EWT: 71 DEGC LWT: 60 DEGC Flow Rate: 0.81 L/S	S8 CHW EAT: 26.6 DEGC DB/19.3 DEGC WB LAT: 12.8 DEGC DB/11.4 DEGC WB Flow Rate: 2,448 L/S EWT: 5.5 DEGC LWT: 13.8 DEGC Flow Rate: 1.87 L/S	Unknown Assumed inoperable	2,448 L/S (5,190 CFM @1,318 RPM/3.1BHP) - Design 7.5 HP @1,800 3" WG		Lecture Hall 216	1983 fan and coil design data presented where available
12	AHU 12	Mixed	No	S12 50% EG from existing fifth floor HX EAT: 13 DEGC LAT: 21 DEGC Flow Rate: 1,886 L/S EWT: 71 DEGC LWT: 60 DEGC Flow Rate: 0.47 L/S	S12 CHW EAT: 26.2 DEGC DB/19.3 DEGC WB LAT: 12.8 DEGC DB/11.4 DEGC WB Flow Rate: 1,886 L/S EWT: 5.5 DEGC LWT: 13.8 DEGC Flow Rate: 1.45 L/S	Unknown Assumed inoperable			Second Floor South West section (Stack room and library)	1983 fan and coil design data presented where available Supply: Enviro Audit June 2020: 2,454 (5,200 CFM, 90% of design) OA air damper fully closed at time of audit/ return fully open/return air fully exhausted Return: Enviro Audit June 2020: 1778 L/S (3767 CFM) Fully exhausted at time of audit



13	AHU 13	Mixed	No	Glycol 5th floor steam to Glycol (~73 DEGC - 163 DEGF)	DX Coil	Unknown Assumed inoperable	Design: 10 HP		Clinic 2 - (207, 207K, and 207D) Double floor height ceiling	Supply: Enviro Audit June 2020: 3,791 L/s (8,032 CFM - 77% of Design) OA 10%/return air 90%/exhaust assumed fully closed based on meas. at time of audit Return: Enviro Audit June 2020: 3,777 L/S (8,003 CFM - 76% of design)
14	AHU 15	Mixed	No	Glycol 5th floor steam to Glycol (~73 DEGC - 163 DEGF)	DX Coil	Unknown Assumed inoperable	Design: 15 HP		Second floor east offices 207 (A,B,C,E,F,V) attached to Clinic 2, Double floor height ceiling	Supply: Enviro Audit June 2020: 4,713 L/S (9,986 CFM - 95% of design) Return: Enviro Audit June 2020: 2,980 L/S (6,314 CFM) OA 10%/Return 90%/exhaust fully closed at time of audit
15	AHU 16*	Mixed	Yes	S16 50% EG from existing fifth floor HX EAT: 13 DEGC LAT: 21 DEGC Flow Rate: 24,660 L/S EWT: 71 DEGC LWT: 60 DEGC	S16 CHW EAT: 26.7 DEGC DB/19.4 DEGC WB LAT: 12.8 DEGC DB/11.4 DEGC WB Flow Rate: 24,660 L/S EWT: 5.5 DEGC LWT: 13.8 DEGC Flow Rate: 19.3 L/S	Unknown Assumed inoperable	S16 (1983 data) 24,660 L/S (52,250 CFM @717 RPM/51.6 BHP)) 60HP @1800 RPM 5" WG	R16 (1983 data) 20,280 L/S (42,970 CFM @ 913 RPM/28.1 BHP) 40 HP @1800 RPM 1.25" WG Exhaust Fan E-48 14130 L/S (29,940 CFM @ 899 RPM/17.3 BHP)	Basement S&E, Leve1 I SE, Level 2 SE, Level 3 S,	1983 fan and coil design data presented where available Supply: Enviro Audit June 2020: 15,387 L/S (32,603 CFM) @ 42Hz outside air damper fully open/return air damper fully closed Return: Enviro Audit 2021: Supplies 27,875 CFM



				Flow Rate: 6.14 L/S				25 HP @1800 RPM		
16	AHU 17	Mixed	Yes	S17 50% EG from existing fifth floor HX EAT: 13 DEGC LAT: 21 DEGC Flow Rate: 14,945 L/S EWT: 71 DEGC LWT: 60 DEGC Flow Rate: 3.72 L/S	S17 CHW EAT: 26.7 DEGC DB/19.4 DEGC WB LAT: 12.8 DEGC DB/11.4 DEGC WB Flow Rate: 14,945 L/S EWT: 5.5 DEGC LWT: 13.8 DEGC Flow Rate: 11.7 L/S	Unknown Assumed inoperable	S17 (1983 data) 14,945 L/S (31,670 CFM @1611 RPM/34.5BHP) 4.5" WG	R17 (1983 data): 12,428L/S (26,330 CFM @ 1,027 RPM) each 20 HP @1800 RPM 1.25" WG	Basement rooms 18 (A,B,C,K), 17, 17K, 16, 14K, Mezanine?, First floor North Wing, Second floor North wing, Third floor North East offices	1983 fan and coil design data presented where available
17	AHU 20	Mixed	No	Glycol 5th floor steam to Glycol (~73 DEGC - 163 DEGF)	CHW	Unknown Assumed inoperable			Basement Lecture Hall 19, 19 (A,B,C)	



18	AHU 21*	Mixed	Yes	Glycol Penthouse steam to Glycol (~70 DEGC - 160 DEGF) (Glycol HX: P-2A and P-2B - 15 HP each, max flow 23.3 L/S (370 GPM))	S21 CHW EAT: 27 DEGC DB/19.7 DEGC WB LAT: 12.8 DEGC DB/11.4 DEGC WB Flow Rate: 34,360 L/S EWT: 5.5 DEGC LWT: 13.8 DEGC Flow Rate: 28 L/S	Steam from CSG - runs at ~ 50% -EMRS Humidification coils capacity 150 lb/hr x 2 coils	S-21 (1983 data) Volume: 35,360 L/S (74,925 CFM @ 863 RPM/96.4 BHP) 125HP @1800 RPM 6.5" WG	R 21A (1983 data): 13,750L/S (29,130 CFM @ 1141 RPM) each 20.9 HP @1800 RPM 1.625" WG R 21B (2017 Data): 16,132 L/S (34,181 CFM) 20.1 HP @ 1725 RPM 500 pa (2.0" WG) TEF (2017 Data): 6,132 L/S (12,993 CFM) 10 HP @1725 RPM 400 pa (1.6" WG)	rooms 173,181,178,172,24, 25, second floor west offices, third floor west offices and 9 South West offices (366,366A,365,386, 384,383,368,371,373)	1983 fan and coil design data presented where available Supply: Enviro Audit June 2020: 11,391 L/S (24,136 CFM) 2,328 L/S (4,932 CFM) OA or ~20% Enviro Air Audit 2021: Supplies 24,944 CFM Return: Enviro Audit June 2020: 9,063 L/S (19,203 CFM)
19	AHU 24	Mixed	No	S24 EAT: 21 DEGC LAT: 32 DEGC Flow Rate: 63 L/S EWT: 66 DEGC LWT: 49 DEGC Flow Rate: 0.14 L/S	N/A	Unknown Assumed inoperable	471 L/S (1,000 CFM @3402 RPM) 3/4 HP @2600 RPM		Parking Ramp zone	1983 fan and coil design data presented where available



20	AHU 31	Mixed	Yes	N/A	S31 CHW EAT: 43 DEGC DB/24 DEGC WB LAT: 7.2 DEGC DB/12.8 DEGC WB Flow Rate: 4500 L/S EWT: 5.5 DEGC LWT: 13.8 DEGC Flow Rate: 28 L/S	11.4 KG/HR	4,672 L/S (9,895CFM) 10HP 375 pa	4434L/S (9395CFM) 5HP 250pa	4th floor office area	coil and fan Data based on IFC drawings dated 2017 Active during office hours
21	BAHU (Air Compressors)	100% OA	Yes	N/A	N/A	N/A	9000 CFM 8.25 BHP @ 1750 RPM	9000 CFM 8.21 BHP @ 1750 RPM	Mech room 14	As Built drawings data dated March 2021
22	AHU4-1 (Entrance)	Mixed	No	Glycol 5th floor steam to Glycol (~73 DEGC - 163 DEGF) Enthalpy wheel	N/A	N/A	12,000 CFM - Design	9,770 CFM (1,100 CFM to exhaust) - EMRS Continuous	Main Entrance	~20% OA from EMRS spot check

- Design data may be outdated

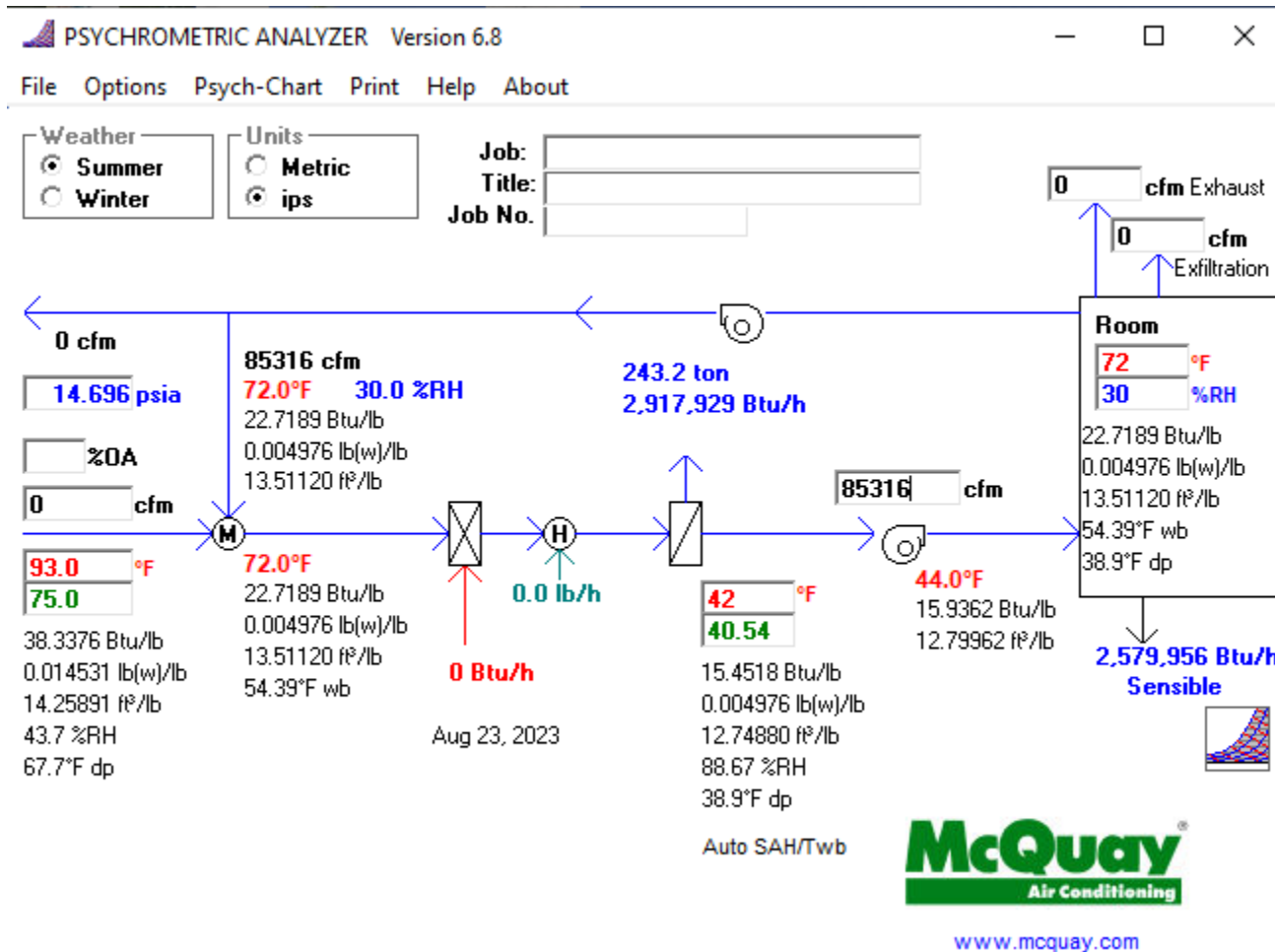

*Estimated recovered heat from available and viable AHUs exhaust volume that is proposed to be chilled for heat recovery, to feed the WSHWP system.

*Heat recovery system losses and efficiency are excluded from this estimate at this stage of the proposed concept.



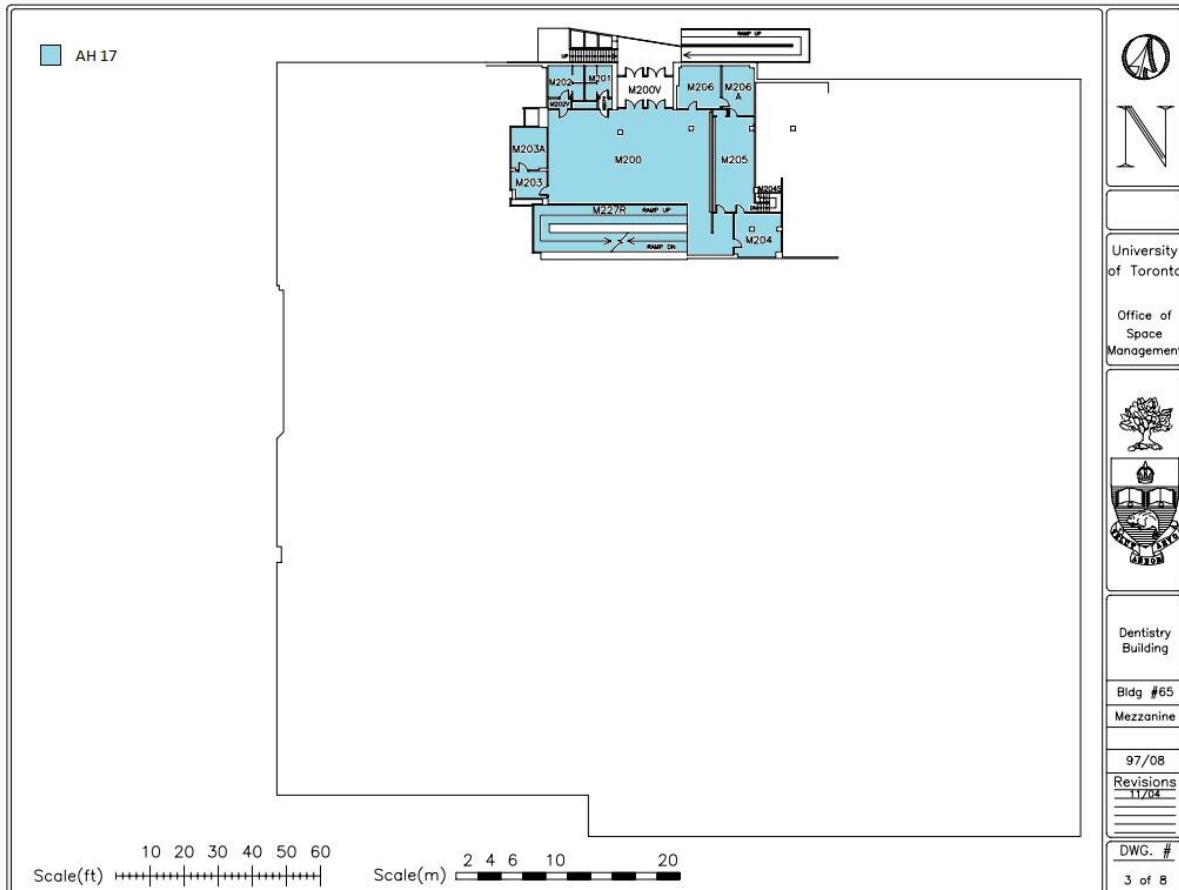



- AH 4
- AH 5
- AH 7
- AH 16
- AH 17
- AH 20
- AH 21
- AH 24



N

University of Toronto
 Office of Space Management

Dentistry Building
 Bldg #65
 1st Floor
 97/08
 Revisions
 08/01
 07/02
 06/03
 DWG. #
 2 of 8



- AH 8
- AH 12
- AH 13
- AH 15
- AH 16
- AH 17
- AH 21

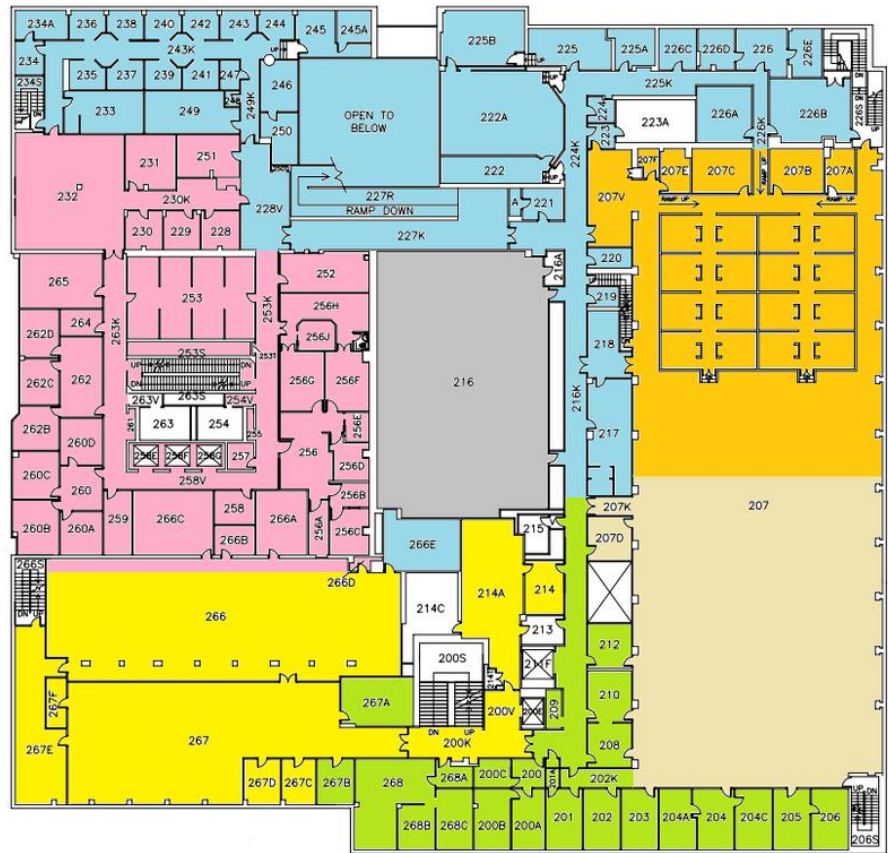

Scale(ft) 10 20 30 40 50 60

Scale(m) 2 4 6 10 20

N

University of Toronto

Office of Space Management

UNIVERSITY OF TORONTO

Dentistry Building

Bldg #65

2nd Floor

97/08

Revisions
08/01
08/03
07/03
11/04

DWG. #

4 of 8



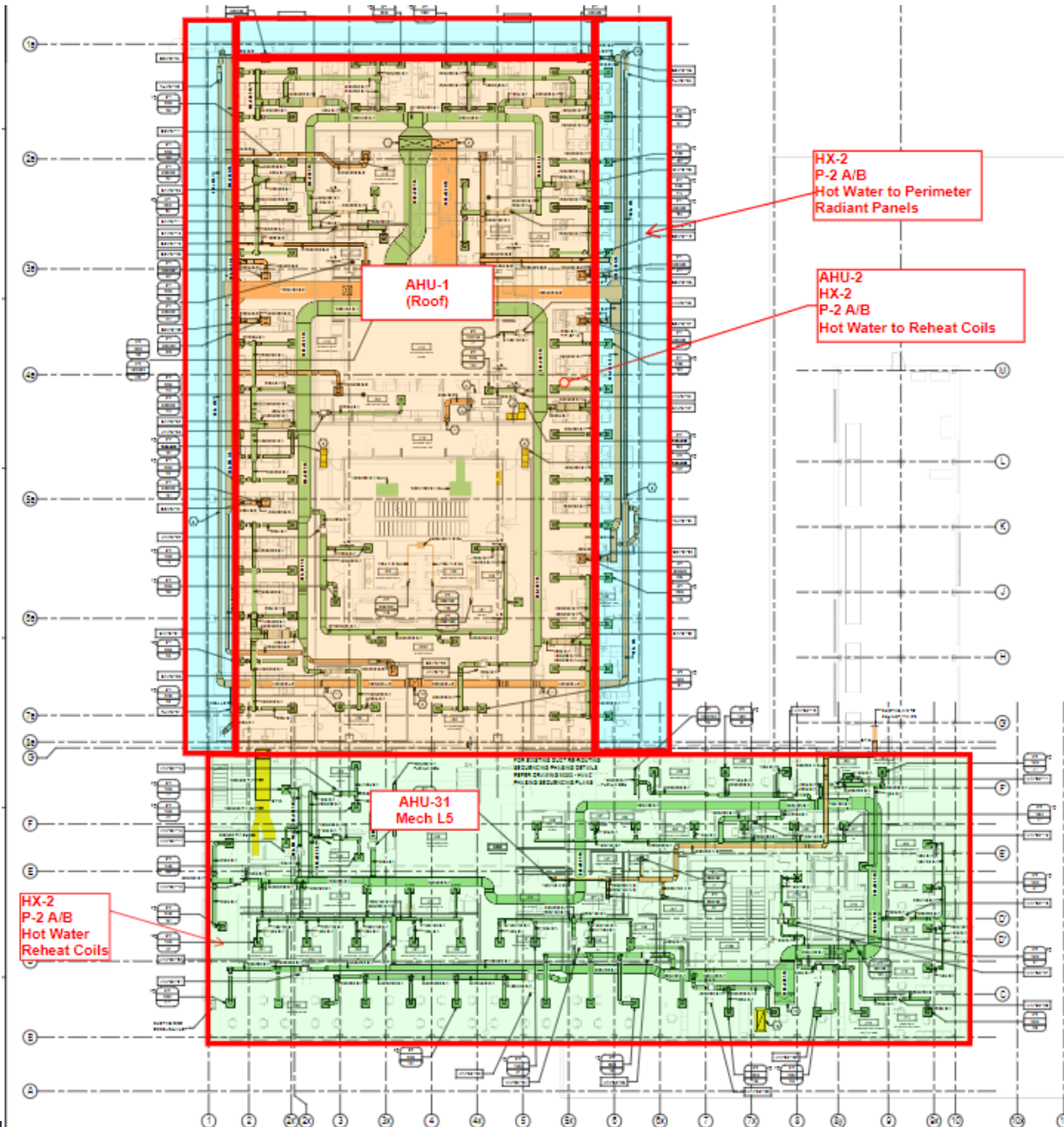

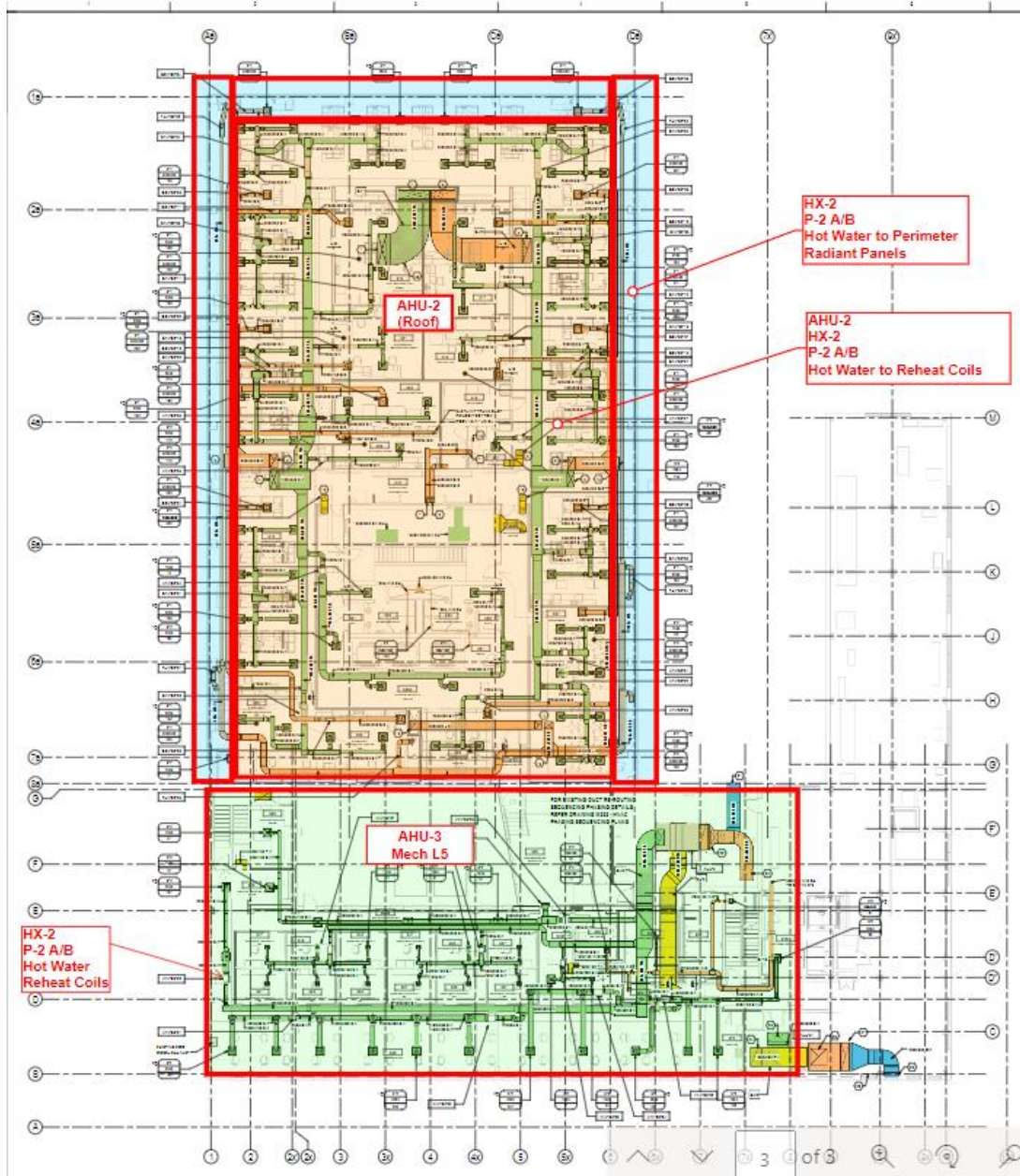



Below is a diagram of a lab AHU connected to a Siemens control system.

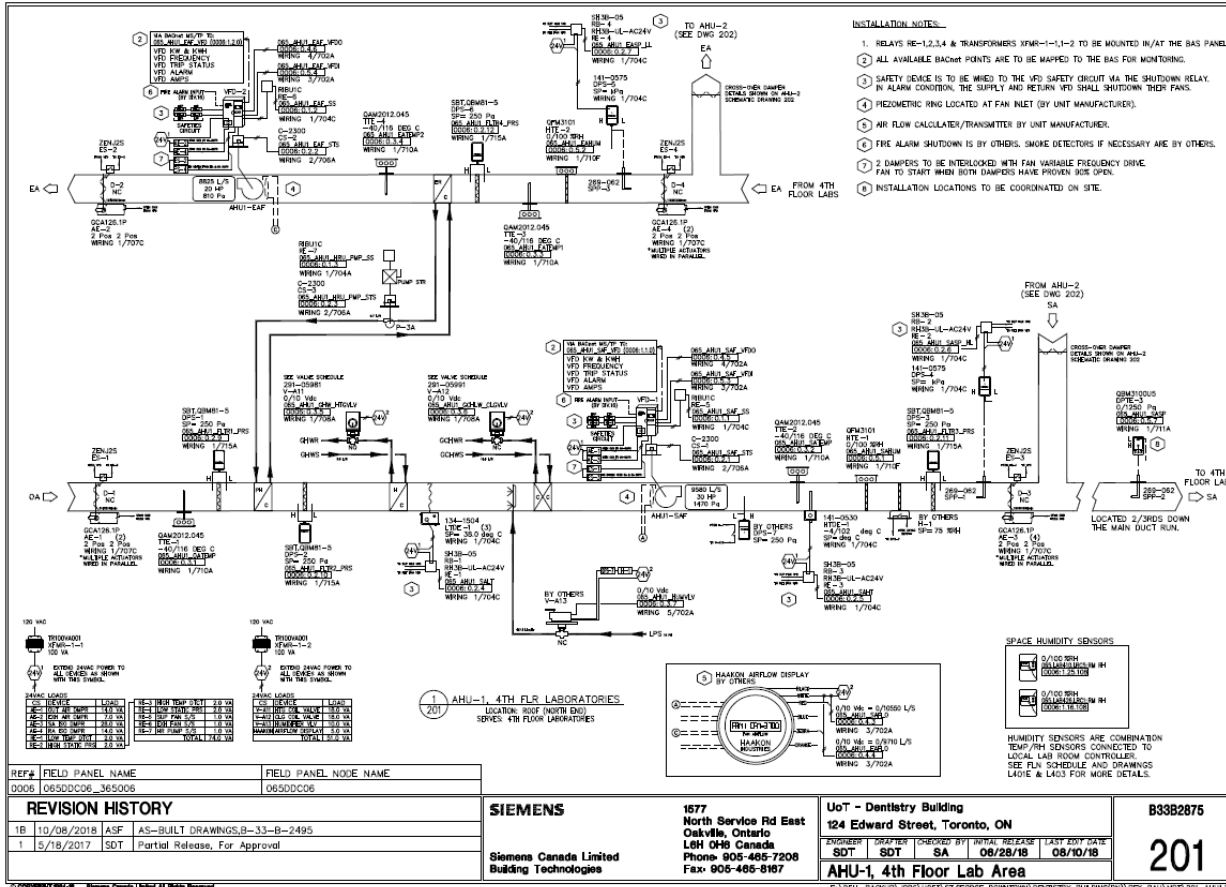



APPENDIX B – EXISTING CONDITIONS HIGH LEVEL SCHEMATIC DIAGRAM

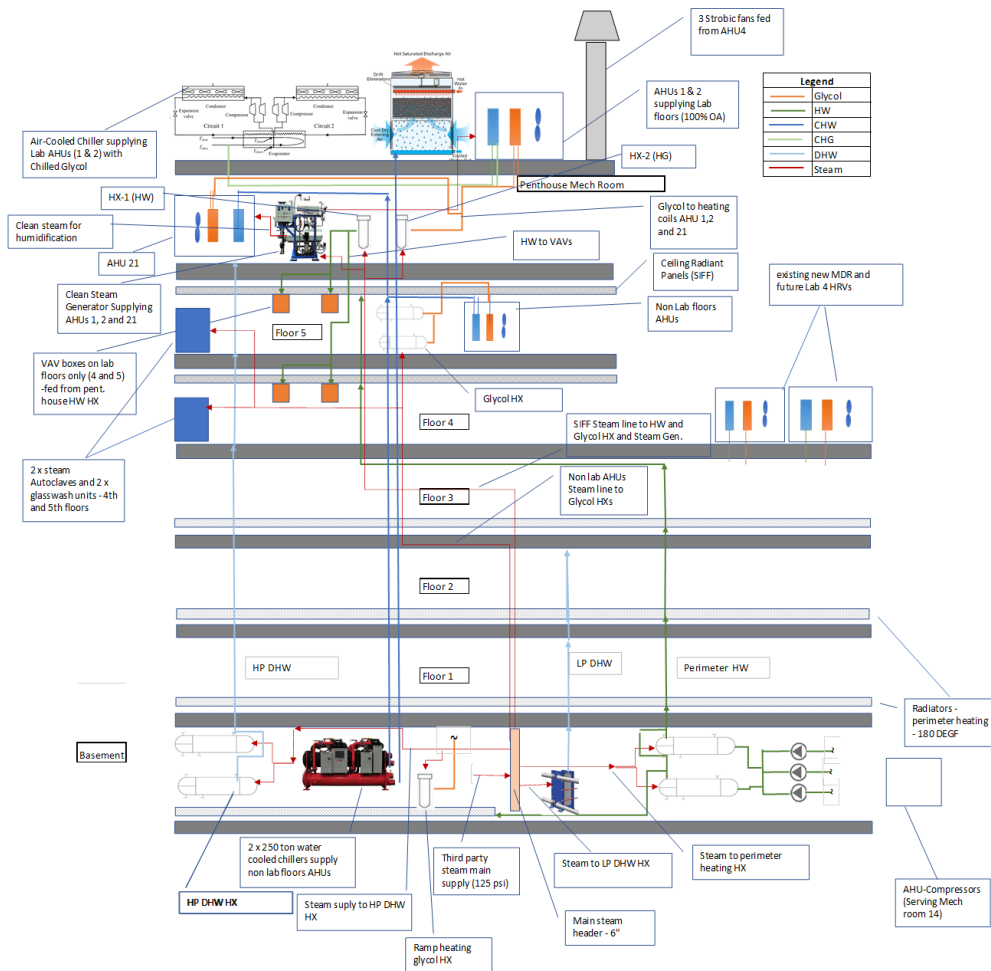



APPENDIX D - SAVINGS BY DESIGN (SBD) WORKSHOP SIMULATION

Model Inputs – Using

Modelled GFA	23,484 m ²
# Floors	5-Stories + 1 Level UG
Primary Space Type	Offices, Classrooms, Labs, Clinics
Occupancy/Gain Schedule	Offices: NECB Schedule A Classrooms: NECB Schedule D Labs & Clinics: NECB Schedule H
Occupancy	≈950 peak occupancy
Heating Set Point	71.6 °F Setback: 64.4 °F RH: 30%-70%
Cooling Set Point	75.2 °F Setback: OFF RH: 30%-70%

Window to Wall Ratio

North	16%
East	19%
South	28%
West	13%
Overall	19%





Envelope Specifications

	SBD Reference (NECB 2015 + SB-10)	Baseline/Proposed
Opaque Above Ground Wall Performance	Climate Zone 5 R-20.4	Above Grade Masonry Wall Clear Field Effective R-5.0 Overall Effective R-4.0 <i>Includes the effects of thermal bridging</i>
Below Grade Walls	Climate Zone 5 R-14.9	Uninsulated Below Grade Wall Overall Effective R-1.5
Roof Performance	Climate Zone 5 R-37.0	Roof Overall Effective R-22
Glazing Performance	Climate Zone 5 USI-1.90 W/m ² -°K	Average Window Performance USI-5.19 W/m ² -°K
Solar Heat Gain Coefficient (SHGC)	Climate Zone 5 SHGC-0.40	Average Window SHGC SHGC-0.57
Window-to-Wall Ratio	19%	19%
Overall Envelope Performance	R-19.2	R-5.7

R-Values represent the effective thermal insulation values of the assembly, including the effects of thermal bridging

USI-Value is the overall coefficient of heat transfer for the window including framing





Electrical Specifications

	SBD Reference (NECB 2015 + SB-10)	Baseline/Proposed
Electrical Equipment Power Density (W/m ²)	<u>Per As-Built Design</u> Receptacle & Elevator Load: 12.1 W/m ² Vacuum Pumps & Compressors: 0.7 W/m ²	<u>Per As-Built Design</u> Receptacle & Elevator Load: 12.1 W/m ² Vacuum Pumps & Compressors: 0.7 W/m ²
Interior Lighting Power Density (W/m ²)	<u>Per SB-10 (2017)</u> Average 8.8 W/m²	<u>Per Design Drawings</u> Average 9.9 W/m²





Reference System Type

Table 8.4.4.7.-A

HVAC System Selection for the Reference Building

Forming Part of Sentences 8.4.4.7.(1) and (3), 8.4.4.9.(1) and (3), 8.4.4.10.(1) and (7), 8.4.4.13.(1), 8.4.4.14.(6) and 8.4.4.18.(6)

<i>Building or Space Type of the Proposed Building</i>	<i>Size of Building or Space⁽¹⁾⁽²⁾</i>	<i>Type of HVAC System Required⁽³⁾</i>
Assembly Area: exhibit space, conference/meeting/multi-purpose room, performing arts/motion picture <i>theatre</i> , courtroom, classroom/lecture/training room, place of worship, fellowship hall, sports centre, arena and swimming pool seating area, waiting room	Maximum 4 storeys	System - 3
	More than 4 storeys	System - 6
General Area: office, banking, health care clinic, library, retail/mall concourse, gymnasium, athletic play area, swimming pool, exercise centre, dressing room, lighting control room, atrium	Maximum 2 storeys	System - 3
	More than 2 storeys	System - 6

Table 8.4.4.7.-B

Descriptions of HVAC Systems 1 - 7

Forming Part of Sentences 8.4.4.7.(1), 8.4.4.9.(3) and 8.4.4.18.(3) and (4)

System - 3	Single-zone packaged rooftop unit with baseboard heating	Constant-volume	Air-cooled direct-expansion	Fuel-fired or electric resistance <i>furnace</i> for rooftop, hot water with fuel-fired <i>boiler</i> , or electric resistance for baseboards
System - 4	Single-zone make-up air unit with baseboard heating	Constant-volume	Air-cooled direct-expansion	Make-up air unit: electric or indirect fuel-fired <i>furnace</i> Baseboards: electric resistance or hydronic with fuel-fired <i>boiler</i>
System - 5	Two-pipe fan-coil ⁽²⁾	Constant-volume	Water-cooled water chiller	None
System - 6	Multi-zone built-up system with baseboard heating	Variable-volume	Water-cooled water chiller	Baseboards: electric resistance or hydronic with fuel-fired <i>boiler</i>



Models Inputs

	SBD Reference (NECB 2015 + SB-10)	Baseline/Proposed
Space Heating Plant	<p>████████ District Steam Modelled As: One modulating boiler, 83.3% efficient 180 °F supply, 150 °F return HW supply T reset w/ OA T</p>	<p>████████ District Steam Modelled As: One modulating boiler, 83.3% efficient 180 °F supply, 150 °F return</p>
Space Cooling Plant	<p>Water-cooled centrifugal chiller 44.6 °F supply, 55.4 °F return COP 5.547 (constant speed)</p>	<p>Water-cooled centrifugal chiller 44 °F supply, 51 °F return COP 4.9 (constant speed)</p>
Heat Rejection Plant	<p>Open axial fan cooling tower 85 °F supply, 95 °F return Fan: 0.013 kW/kW (constant speed)</p>	<p>Centrifugal fan cooling tower 85 °F supply, 95 °F return Fan: 0.026 kW/kW (constant speed)</p>
Pumps	<p>HW Pump: 16.6 kW (constant speed) CHW Pump: 16.6 kW (constant speed) CW Pump: 13.3 kW (constant speed)</p>	<p>HW Pump: 16.6 kW (constant speed) CHW Pump: 16.6 kW (constant speed) CW Pump: 13.3 kW (constant speed)</p>
DHW Heating Equipment	<p>████████ District Steam Modelled As: Gas DHW Heater, 90% efficient</p>	<p>████████ District Steam Modelled As: Gas DHW Heater, 90% efficient</p>
DHW & Process Loads	<p>NECB 2015 DHW Flow: 6.2 GPM Lab/Clinic Process Load: 0.82 MBtu/h</p>	<p>NECB 2015 DHW Flow: 6.2 GPM Lab/Clinic Process Load: 0.82 MBtu/h</p>





Models Inputs HVAC System: Whole Building

	SBD Reference (NECB 2015 + SB-10)	Baseline/Proposed
HVAC System Type	NECB 2015 System-6 Multi-zone VAV system with CHW coils and HW baseboards.	<u>Air Handling Units (AHUs)</u> AHUs with CHW and HW coils + 2 AHUs with air-cooled DX cooling and HW heating. Perimeter HW baseboards. Reheat in some 4 th and 5 th floor spaces
Air-Side Heat Recovery	55% Latent and Sensible Effectiveness <i>Per SB-10 (2017)</i>	Not Installed
Heating	Hot Water Baseboards	Hot Water Coils
Cooling	Chilled Water Coils	Chilled Water Coils Air-Cooled DX (EER 11.0)
Fan Power	Basement to 5 th Floor: VAV Supply: 0.86 W/cfm Return: 0.39 W/cfm	Basement to 3 rd Floor: Constant Speed 4 th and 5 th Floor: VAV Supply: 1.0 W/cfm Return: 0.45 W/cfm
Outside Air Supply	Recovered OA: 19,925 cfm Total: ~ 29,000 cfm	Recovered OA: 0 cfm Total: ~ 29,000 cfm



Other Model Inputs

Typical for both the Reference, Baseline and Savings By Design energy models unless otherwise specified

- Operational Infiltration Rate
 - 5.5 L/s-m² (@ 75Pa) of exterior surface area
- Occupancy
 - Assumed ~ 950 Occupants
- Equipment
 - Modelled according to sub-meters and utility calibration
- Outdoor Air
 - Modelled according to design drawings and utility calibration ~ 29,000 cfm
- Domestic Hot Water & Hot Water Process Loads
 - DHW per NECB 2015 space by space peak hot water demand
 - Process load modelled according to sub-meters and utility calibration



Model Calibration - Electricity Use

Modelled vs Historical Electricity Consumption

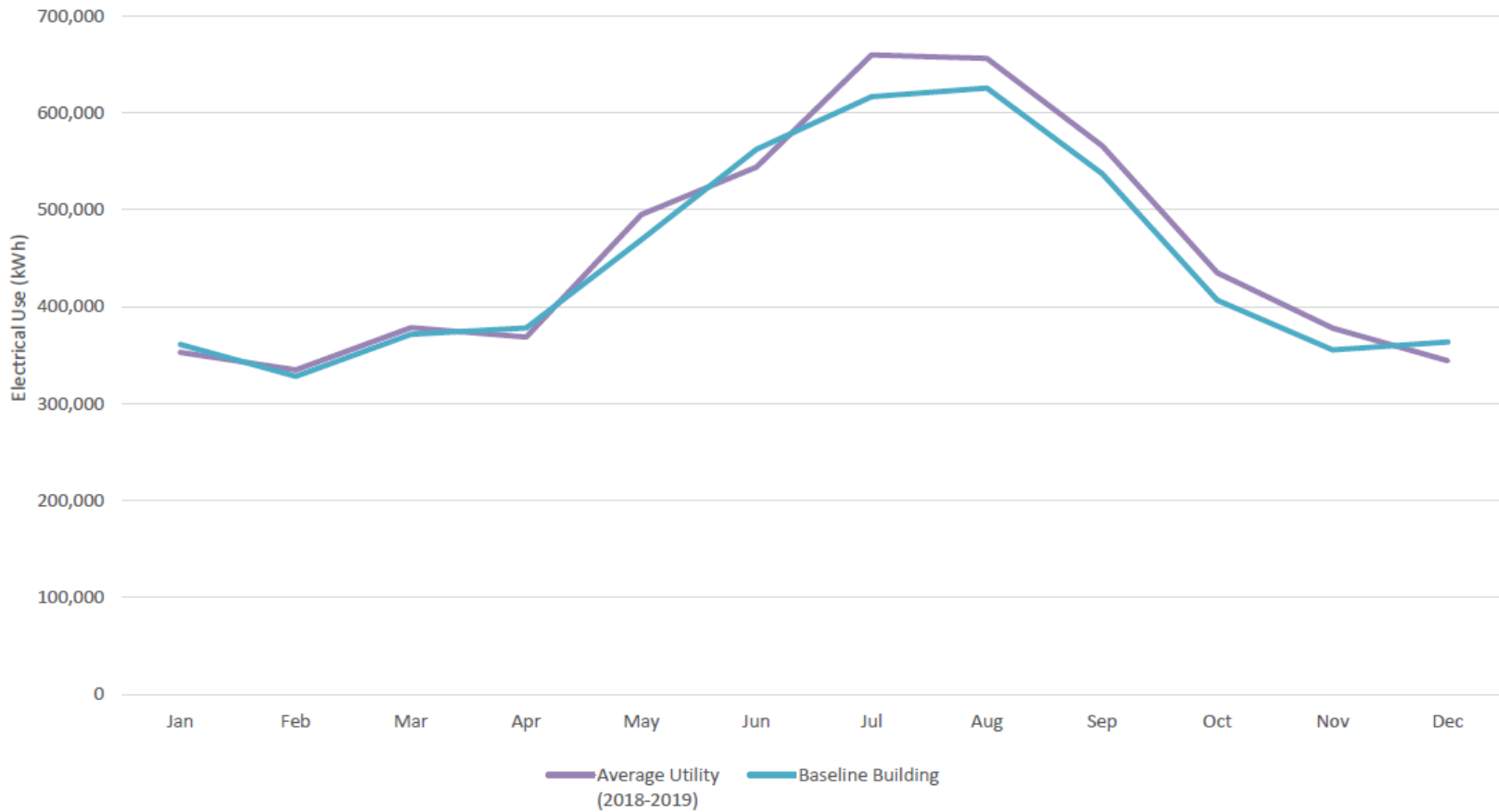

savingsbydesign.ca



Model Calibration - Steam Use

Modelled vs Historical Steam Consumption

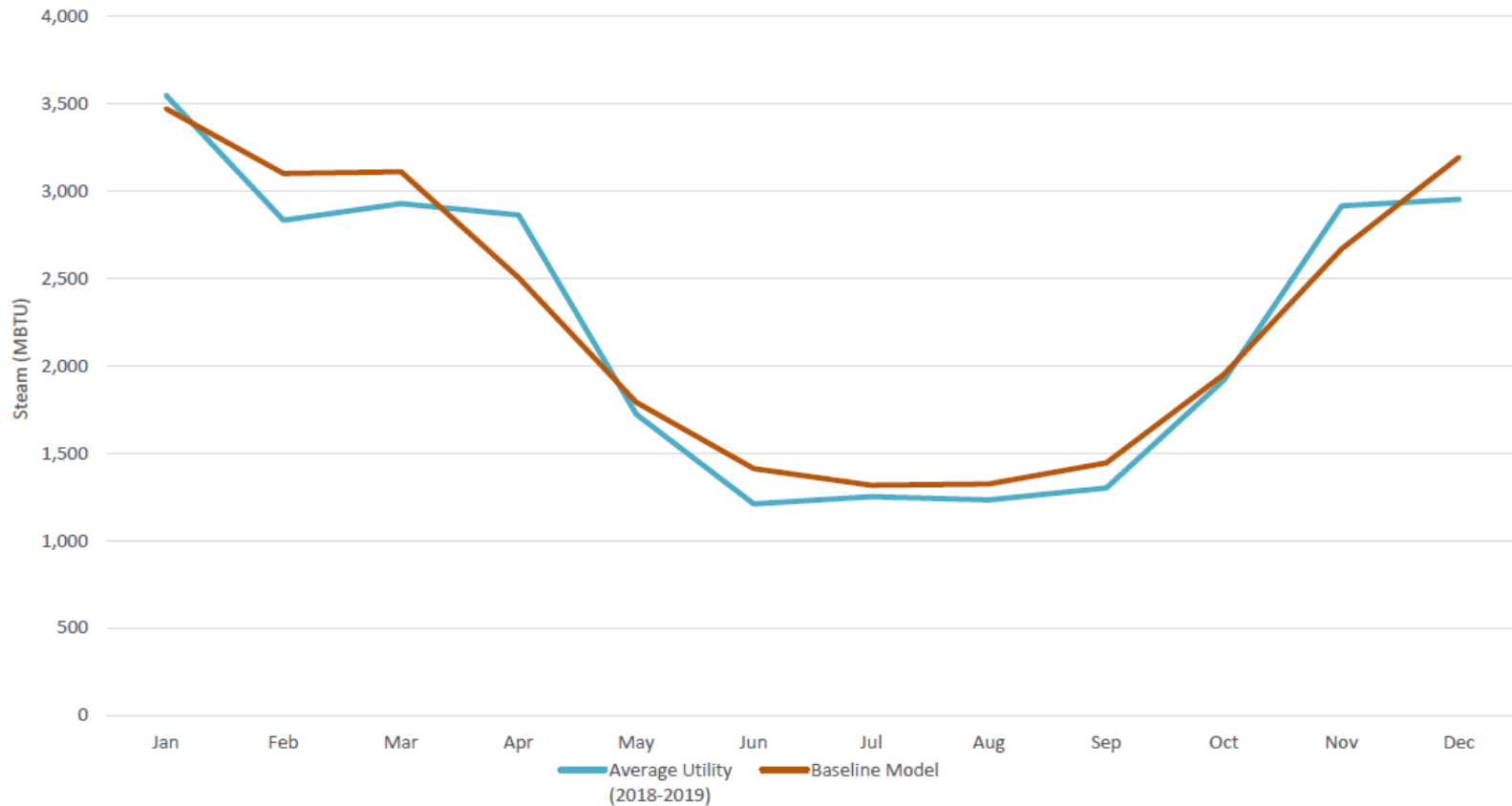



Total Annual Energy Consumption

	Reference Building	Baseline Building	Savings
Total Consumption ekWh	11,274,883	15,057,919	-33.6%
Consumption per ekWh/m ²	480.1	641.2	-33.6%
Electricity Consumption kWh	4,657,573	5,375,968	-15.4%
Natural Gas Consumption m ³	626,835	917,138	-46.3%

The Baseline Building exceeds the Reference Building in energy use and GHG emission by **33.6% and 41.3%** respectively.

Baseline Building vs Reference Building	Savings
Electricity Consumption (kWh)	-718,395
Electricity Cost (\$)	-\$104,167
Natural Gas Consumption (m ³)	-290,303
Natural Gas Cost (\$)	-\$71,124.24
Total Energy Consumption (ekWh)	-3,783,036
Total Annual Cost (\$)	-\$175,292
Total GHG Emissions Reduction from Reference (Kg CO ₂ Eq)	-587,205



Electricity is priced at \$0.145/kWh; Natural Gas is priced at \$0.245/m³. This may not reflect the actual pricing available to the proponent.

savingsbydesign.ca



Preliminary Results – Consumption by End Use

SB-10 Reference Building vs Baseline Building

33.6%

Energy Use Increase

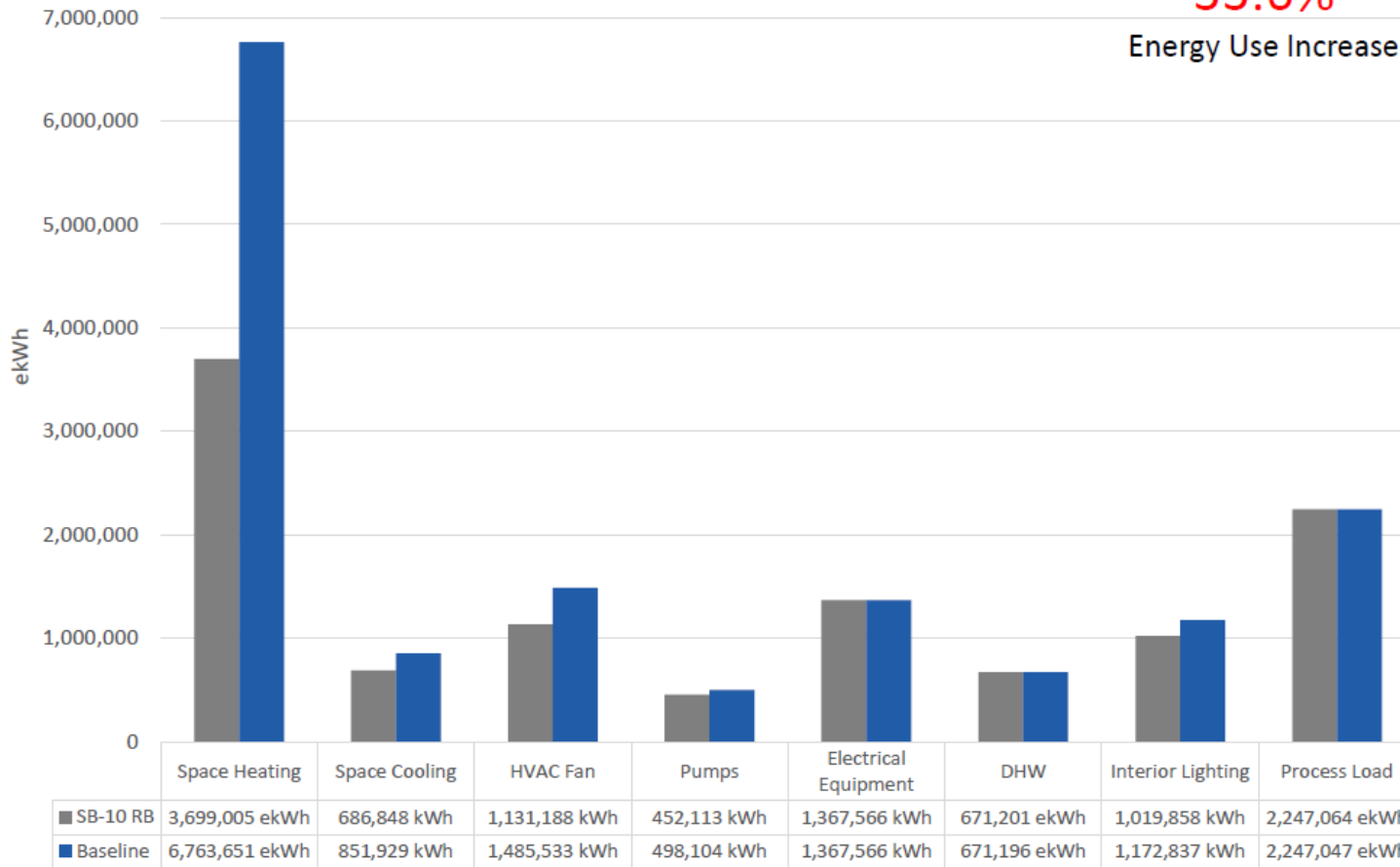

savingsbydesign.ca



Preliminary Results – Energy Cost by End Use *

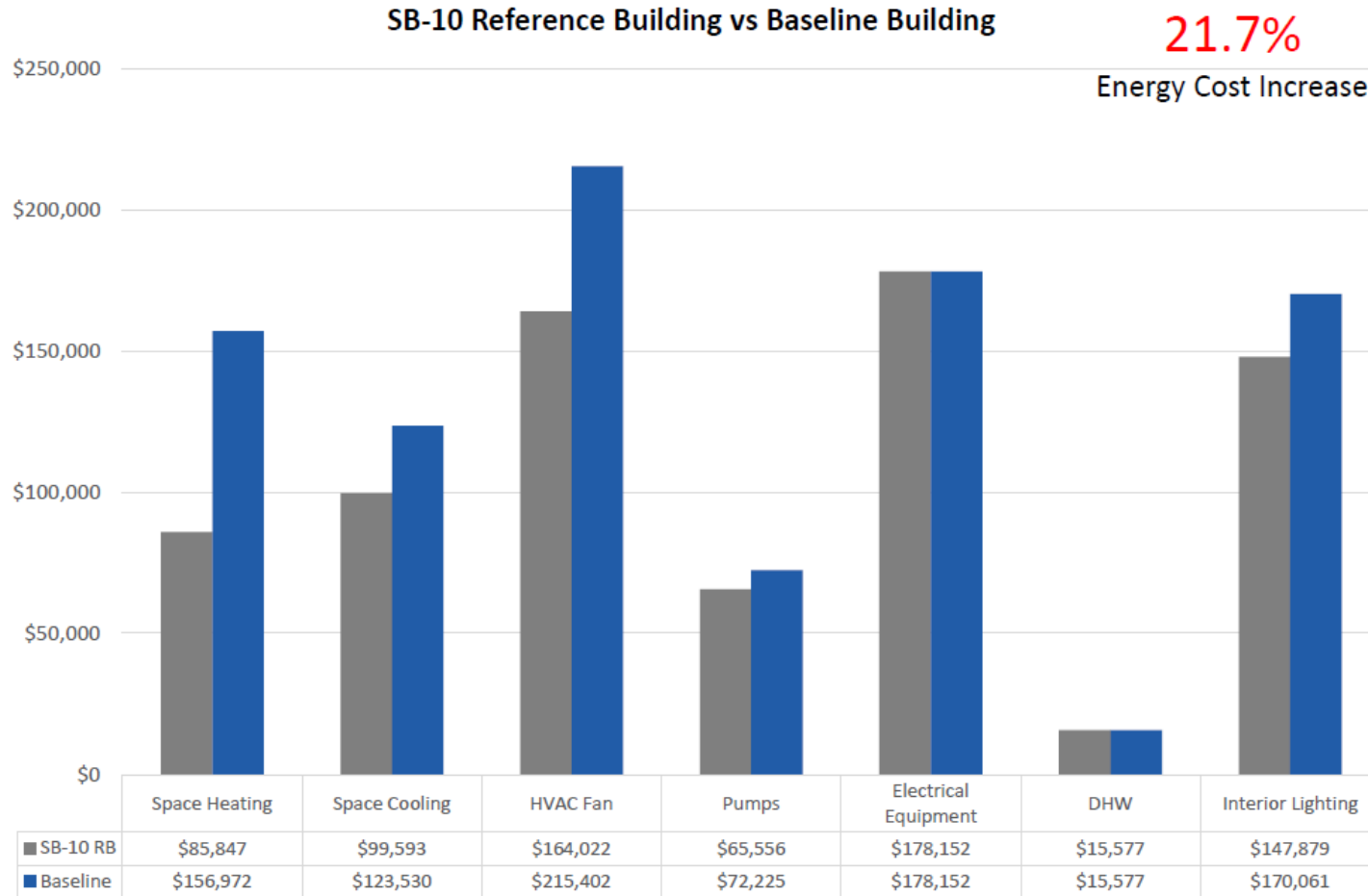

* Cost are based on electricity & NG rates that are an average used for the SBD Program and may not accurately reflect the pricing for the actual project. Proponents should validate prices with their Utility.

savingsbydesign.ca



Absolute Performance Metrics (EUI, TEDI, & GHGI)

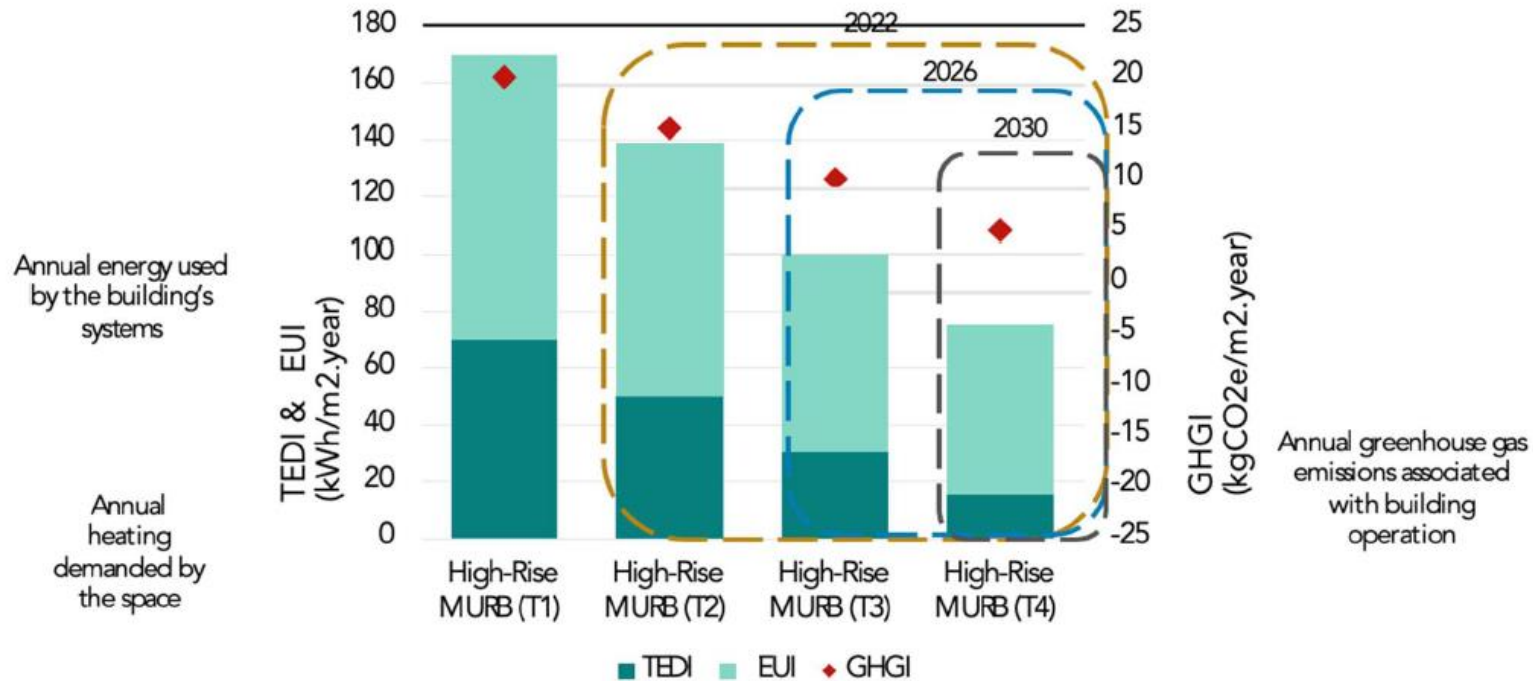

EUI: Energy Use Intensity (kWh/m².yr)

TEDI: Thermal Energy Demand Intensity (kWh/m².yr)

GHGI: Greenhouse Gas Intensity (kgCO₂e/m².yr)



savingsbydesign.ca



Simulation Results – Baseline Building

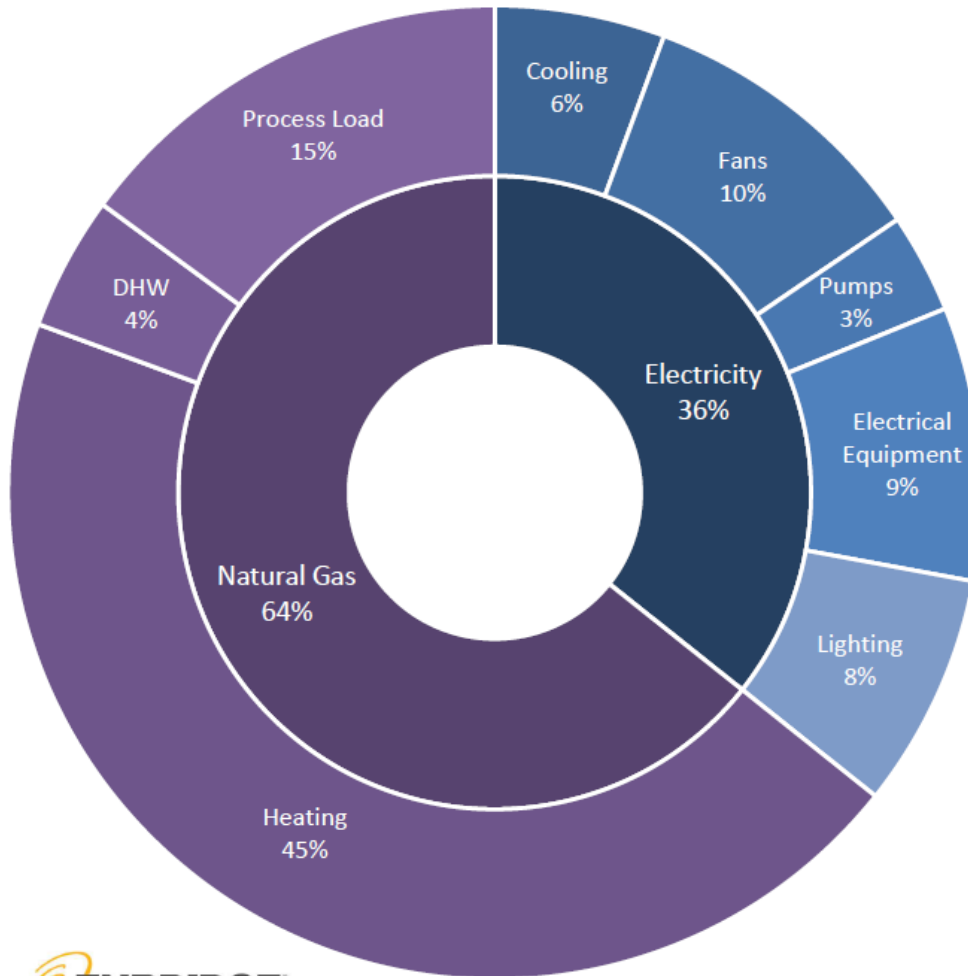

EUI (kWh/m ² -yr)	641.2
TEDI (kWh/m ² -yr)	235.5
GHGI (ekg CO ₂ /m ² -yr)	85.6
Energy Cost (\$/m ² -yr)	██████████





McCaul Complex Excerpts only

UNIVERSITY OF TORONTO

Project LEAP Concept Report

July 8th, 2022



ABBREVIATIONS

AHRI	Air Conditioning, Heating and Refrigeration Institute
AHU	Air Handling Unit
ASHRAE	American Society of Heating, Refrigerating and Air-Conditioning Engineers
ASME	American Society of Mechanical Engineers
ATS	Automatic Transfer Switch
BAS	Building Automation System
BAU	Business as Usual
BCIT	Bahen Centre of Information Technology
BESS	Battery Energy Storage System
BOP	Balance of Plant
CED	Central Electrical Distribution
CFM	Cubic Feet per Minute
CHW	Chilled Water
CMMS	Computer Maintenance Management Systems
CMRS	Central Management and Reporting System
COP	Coefficient of performance
Cogen	Cogeneration Plant
CSP	Central Steam Plant
CSP	Central Steam Plant
CW	Condenser Water
DHW	Domestic Hot Water
EMRS	Energy Management and Reporting System
GA	Global Adjustment
GSHP	Ground Source Heat Pump
GPM	US Gallons per Minute
HTHW	High Temperature Hot Water
Lbs/hr	Pounds per hour (Steam flow rate)
ISS	Ice Storage System
IESO	Independent Electricity System Operator
LDC	Local Distribution Company



LTHW	Low Temperature Hot Water
MSB	Medical Sciences Building
PPH	Pounds Per Hour (Steam)
OSHA	Occupational Safety and Health Administration
OWS	Operator Workstation
TH	Toronto Hydro
THESL	Toronto Hydro Electric System Limited
UMP	Site Utility Master Plan
UPS	Universal Power Supply
VFD	Variable Frequency Drive



3.5 McCaul (MC)

We have combined the following buildings under this group: 1) Health Sciences (HA), 2) Exam Centre and (EX), and 3) Old Administration Building (OA).

Health Sciences (HA) (154)

The Health Sciences Building dates from 1957 and has seven above grade stories plus a basement and a rooftop penthouse plant space. It has a mix of uses including administrative offices, classrooms, teaching labs, basement parking along with auditoriums on the first and sixth floors. It has two bridges, on the second and third floors, which link it to adjacent buildings: EX (255 McCaul Street) and OA (263 McCaul Street).

Exam Centre (EX) (155)

The Exam Centre Building dates from 1917 as industrial warehouse has four floors plus a partial basement space. After 2008 major renovation, U of T has repurposed the building function as a mix of uses including exam center on first to third floors, and administrative offices for facilities and services on fourth floor. It has two bridges, on the second and fourth floors, which link it to adjacent buildings: HA (155 College Street) and OA (263 McCaul Street).

Old Administration Building (OA) (156)

The Administration Building (building 156 - Health and Wellbeing of the University of Toronto is located at 263 McCaul Street. The rectangular shaped building was built in 1915 and was occupied by the Toronto Board of Education. The University acquired the building in 2003 and is now occupied by the University Department of Family and Community Medicine on the third and fourth floors, the Health and Well Being department on the 2nd floor and the Toronto School Board Sesquicentennial Museum and Archive on the first floor. The four-story building has a basement, and a total area is 3029 m². The building is connected to the adjacent buildings 154 and 155 by glass enclosed steel framed elevated walkways.

3.5.1 Existing Conditions

Heating

Third party steam enters the utility tunnel that joins OA and EX about in the middle below the outdoor parking. Steam enters at 200PSI in the utility tunnel and then continues travelling in the utility tunnel and enters EX and reduces to 100PSI and then again to 14PSI to feed existing boiler steam header in the EX Boiler Room. The steam header was originally fed from the disconnected old steam boilers left in place with all insulation removed. The steam header continues to feed:

- One feed from steam travels back via the utility tunnel to OA and converts to South & North HX's in basement and then continues with a steam line up to OA Penthouse MR to feed AHU steam coils. Same line feed steam unit heaters in bridge joining OA & EX. In addition, the steam also feeds DHW HX and is converted via 2 tanks.



- Two domestic hot water tanks located in basement heated by steam coils in tanks. Top tank (LP) supplies DHW up to the 4th floor and the bottom tank (HP) supplies from the 5th to the top floor.
- Another line travels in utility tunnel to OA basement and converts to hot water perimeter and hot to AHU plus convertor for small bridge 154 & 156
- Another steam line (2 lines for redundancy) travels to EX in basement mechanical room to 2 HXs one for perimeter and the other for AHUs. The hot water from the basement mechanical rooms HXs travel to the perimeter radiators and the air handlers on the roof
- There are 2 indoor parking garages in OA that have steam unit heaters
- There is one AHU in EX basement MR that is has steam coils

Gas DHW & Plumbing

Three gas fired domestic hot water heaters provide domestic hot water (DHW) for the buildings EX and OA. The DHW heaters are in the boiler room. Washroom facilities are located on each of the three floors and in the basement. A grey water system consists of rainwater cistern tanks, pumps in basement, and an expansion tank. The system was designed for saving portable water by using collected rainwater for flushing plumbing fixtures.

Chilled Water Systems

There is one air cooled glycol chiller on the roof of EX that supplies cooling to EX Air Handlers and there is another chiller in EX Basement with corresponding cooling tower on EX roof that feeds HA and OA. They are separate systems. For HA the primary chilled water is used in AHUs and then perimeter/Induction unit in summer. Chiller and chilled water pumps are in EX. Chilled water pumps are variable speed. Cooling coils has 3-way valves at AHUs. Chilled water operating temperature set between 44 to 48°F depending on OAT. Chiller can be OFF on schedule or based on low OAT. Most if not all AHUs in EX have VFD on supply and return fans.

Health Science Ventilation & BAS

The building had a major renovation in the early 2000s that included installation of several new AHUs in the rooftop penthouse along with a LED lighting retrofit in 2019. The building recently has completed a roof replacement project and does not have PV panels installed. Except for the steam system, the PRV is on a pneumatic control system. The building automation systems are on DDC controls that date from the time of the major renovation over 15-years ago.

Heating, cooling and ventilation are provided to the spaces via perimeter induction units that are original to the building and separated in a North-South configuration with regards to the AHUs that supply them (AHU 01 and AHU 02, respectively). The induction units have local wall- mounted thermostats that control space temperature via modulating control valve. Control via the local coil water temperature and the water circuits are switched seasonally between heating hot water and cooling chilled water. By Central switch over, not at the unit. CCMS control panel located in basement mechanical room has a summer and winter mode to switch over. Heating water and chilled water switch over valves located in basement mechanical room #091.



AHUs 03 & 04 serves most building spaces on floors 1-7, supplementing the induction systems. AHUs 05 & 06 serves the first and sixth floor auditoriums, respectively. AHU 08 serves the basement and the lobby is served by a fan coil unit in the basement for winter heating. A relatively small, newly installed, AHU serves a classroom space on the 7th floor and includes an air-to-air plate heat exchanger. All the AHUs, except for AHU 08, are in the penthouse plant room which acts as an air return plenum and incorporates exhaust and OA dampers as part of the envelope. AHUs 01 to 06 are on CCMS schedule fan shut- down during unoccupied time. Interior rooms have VAV Boxes (AHU 3 to 6). No reheat coils. Interior rooms have VAV boxes, no induction units.

All AHUs (1 to 6) located in PH Mechanical room at 8th floor. Return air from all the room from building supplying air to mechanical room (return air plenum) through return air Fans (RF1 and RF2). Return air fans supplying air to all AHUs through mixing damper and exhaust through exhaust air damper. RF1 and RF2 have VFD.

- AHU-1,2: supplying air to induction units at north and south
- AHU-3,4: supplying air to east and west side of building through VAV
- AHU-5: supplying air to 1st floor Room 106 and 108 (west of building)
- AHU-6: supplying air to auditorium at level 6, room 610.
- One air compressor located in PH mech room which is used for labs only

One HRV unit located in PH mechanical room which heat the fresh air with exhaust air and supplying to two classrooms on 7th floor.

- AHU-1: South Induction - SP 64.4°F
- AHU-2: North Induction - SP 64.4°F
- AHU-3: West Interior - SP 64.4°F
- AHU-4: East Interior - SP 63.5°F
- AHU-5: Auditorium 1st floor- SP 63.5°F
- AHU-6: Auditorium 6th floor-SP 63.5°F

The BAS is JCI

- JCI NAE controllers @ 3 are overloaded controllers (>120%)
- JCI access via launcher.

Health Sciences Third Floor Server Room

A third-floor data server room (room no.309) has two air-cooled Liebert units with the condenser located at EX Roof.



Exam Centre AHU's, Ventilation, & BAS

The five air-handling units and one air-cooled chiller are also installed on the roof. The boiler room located in basement and occupied two floor space, and a 500-ton chiller in the chiller room on ground floor serves the other buildings.

The main condensate return system is in the basement boiler room and consists of a condensate collection tank and two condensate pumps. Two heating exchangers (HE-1&HE-2) using steam as primary heating source to feed the hot water heating system and glycol heating system.

Chilled water pumps, and glycol heating pumps are equipped with VFDs, and the hot water pumps are running at constant speed.

The five AHUs are equipped with glycol heating coils, and cooling coils.

- AHU-1 serves level-1 basement space and provides cooling and ventilation.
- AHU-2 serves level-2 exam room RM200 and provides cooling and ventilation.
- AHU3 serves the lobby area and provides cooling and ventilation.
- AHU-4 serves the third-floor exam rooms and provides cooling and ventilation.
- AHU-4 serves the fourth floor F&S office and provides cooling and ventilation.
- The BAS is an ALC standalone system with local access only.

Old Admin AHU's & Ventilation & BAS

- Basement AHU has steam heating and DX for cooling which feeds 25% of 1st floor rooms.
- Two air compressors are in basement. One in service and one on STBY. Air compressor used for pneumatic control for AHUs.
- Small steam to glycol HE located in basement, used for heating radiators at the bridge to Building 154 through heating glycol circulation.
- This building has local control only. No CCMS, EMRS, and BAS.
- Two DCW booster pumps located in basement mech room have VFDs.
- AHU-2 at 2nd floor mech room:213 and AHU-3 at 3rd floor room 317.
- AHU-2 &3 have heating water from basement HE and 3-way valve at AHUs
- AHU-2,3 have chilled water from exam center and 3-way valve at AHUs.
- All AHUs have no VFDs for supply and Return Fans.
- Basement AHU-1: for some rooms (25%) at 1st floor
- 2nd floor AHU-2: For 2nd floor and partially 1st floor.
- 3rd floor AHU-3: For 3rd, 4th, 5th floors.



- No humidification in AHUs. No VAVs, and no reheat.
- All the rooms have hot water radiators. T-Stat controls radiator's heating output.
- There is no BAS in Old Admin

Exam Centre Electrical

Electrical Main Service

The building is supplied with a 2500A, 120/208V, 3 phase, 4 wire service from Toronto Hydro. The incoming service conductors enter from the Toronto Hydro vault and feeds the main switchboard. The incoming service conductors are housed in a protective enclosure.

Electrical Distribution

There are Toronto hydro meters, located within the main electrical room, for the Supply building and the Old Administration building.

Emergency Power

There is an existing Cummins, 225kW, 120/208V standby generator for the building.

Solar PV on Roof

There has been 67 kWac solar panels installed on the roof. Annual electricity generation is approximately 73,000 kWh tied into the building hydro meter.

Lighting

Throughout the building the lighting fixtures comprise of PL/CFL pot lights, under cabinet LED task lights, T5 fluorescent one or two-lamp fixtures. Some of T5 fixtures in stairwells recently have been converted to



3.5.2 Energy Conservation Measures (ECMs)

The following ECMs are proposed for further analysis at McCaul.

MC-ECM-01: Upgrade Lighting in EX & OA

a) Overview

This measure proposes that lighting be updated to more efficient in EX & OA.

EX Lighting

Throughout the building the lighting fixtures comprise of PL/CFL pot lights, under cabinet LED task lights, T5 fluorescent one or two-lamp fixtures. Some of T5 fixtures in stairwells recently have been converted to LED. Main lighting control is by Douglas control system dated back to 2008 major renovation.

Most of the lighting type in the building has not been converted to LED yet. This measure recommends all existing fluorescent based and compact fluorescent based T5 lamps and pot lighting to be replaced with LED equivalent.

OA Lighting

Most of the lighting type in the building has not been converted to LED yet. This measure recommends all existing fluorescent based and compact fluorescent based T8 lamps and pot lighting to be replaced with LED equivalent

b) Economics and Other Benefits

We have only included utility savings and have also taken into consideration both the cooling effect reduction and added heating load. We have not included any operational savings but do expect an operational cost reduction due to longer life LEDs.

Objectives Supported

- Eliminate CO2
- Address deferred maintenance
- Carbon tax avoidance

Principals Applied

- Balance carbon with cost
- Conservation first
- Foster innovative solutions
- Improve comfort and wellness

ECM ID	Electrical Savings						Thermal Savings			Saving Totals	
	kW ^{DR}	kW ^{GA}	kW ^{Pk}	kWh	tCO2e	\$	MMBtu	tCO2e	\$	tCO2e	\$
MC-ECM-01	0	24	24	121,090	4	\$7,107	-146	-11	-\$4,461	-7	\$2,647



c) Calculation Methodology

We have estimate LPD. The LED lamps are expected to reduce the LPD by 44%. This percentage reduction was then applied to the baseline energy model LPD.

d) Constructability

We have assumed the installation work will be done during regular working hours or during low occupancy periods. We propose to install this measure in many areas of the facility including in academic areas so that requires careful coordination. We will create a detailed communication and delivery plan due to the nature of this installation before work commences.

MC-ECM-02: McCaul Electrification

a) Overview

This ECM proposes the electrification of the grouped McCaul buildings EX, OA, and HA.

At a high level conceptually, decarbonizing of steam based heating by using Ground Source Heat pumps with exhaust air heat recovery from AHUs with electric boilers for peak heating (> 140°F). In addition, to centralize cooling for the proposed heat pump to use heat to recharge ground loop in summer. We also propose to convert the dedicated natural gas DHW to electric.

Scope of Work

- Install new Heat Pump 400-Ton @ 160F output in chiller room with 150-Ton geo exchange field in parking lot and garage
- Remove steam boilers in EX boiler room and install 1100kW electric boiler
- Supply hot water from boiler to:
 - To basement MR in OA to replace 2 x HX's (North and South Loops)
 - To PH MR in OA and in OA PH MR remove steam coils and install hot water coils 130°F

Objectives Supported

- *Build resilient low carbon systems*
- *Eliminate CO2*
- *Carbon tax avoidance*

Principals Applied

- *Balance carbon with cost*
- *Reach beyond our own assets*
- *Foster innovative solutions*



- Replace bridge steam heating unit with hot water fed from riser from EX to HA PH MR
- To 2 x HXs in basement EX MR
- To 3 x HX's in OA basement MR and replace 1 A HU steam coil located on basement with hot water
- To 2 x parking garage steam U/H's and replace with hot water
- To HA AHU's steam coils
- Connect the EX PH air cooled chiller to basement chiller in EX
- Install new elect 80 kW DHW and tanks in EX Boiler Room and replace 3 x gas fired DHW in same room
- Install exhaust air coils in AHUs in HA & EX PH and Roof Air handlers

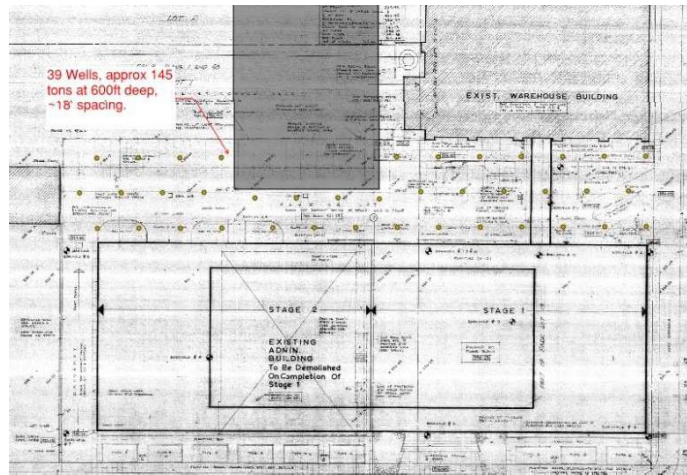

Figure 23: Proposed Location for Geo Field

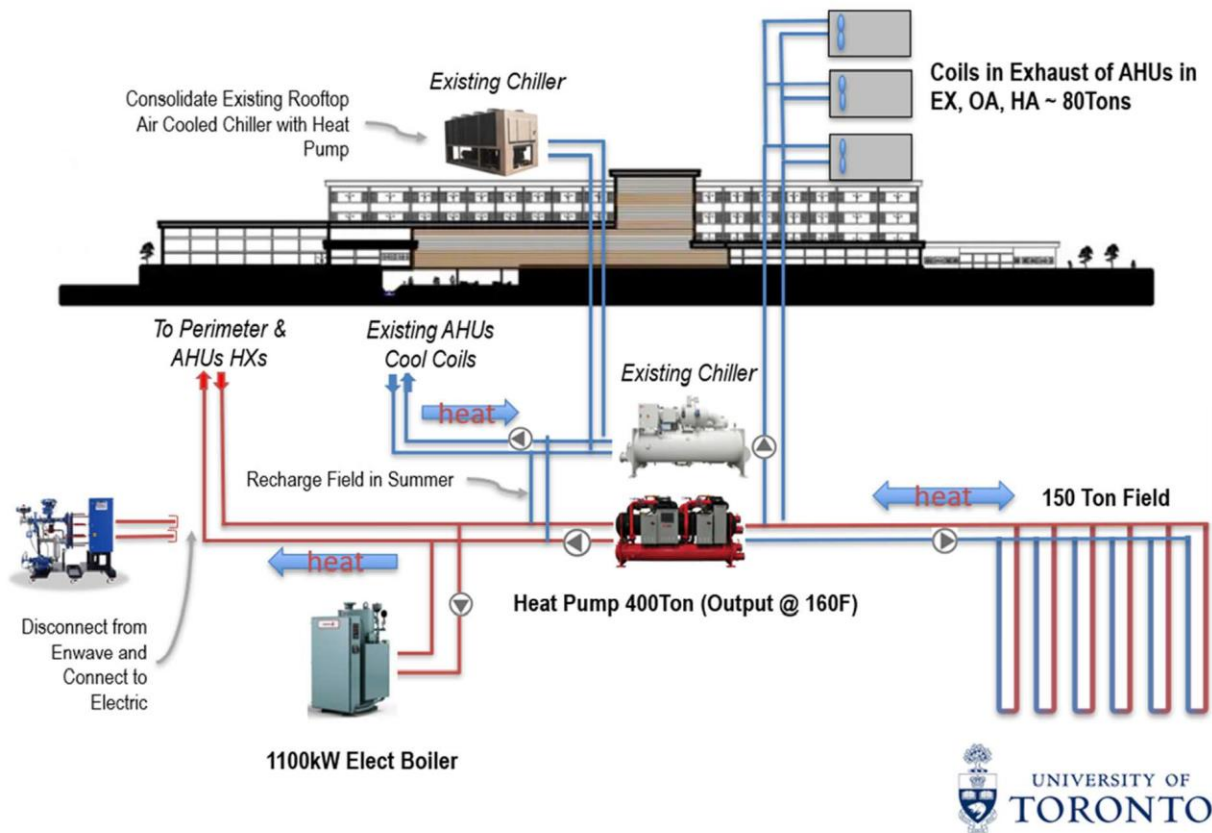

Figure 24: Proposed GSHP Schematic



- Connect exhaust coils in 155 & 154 to chiller room located in 155 basement with new heat pump chiller
- Install adiabatic or electric humidification in AHU's

Nodal Plant Option

This option has been omitted from the report as it may no longer be applicable.

MC-ECM-03: Battery Energy Storage System (BESS)

a) Overview

To further enable demand response and GA avoidance 3MWh hours of battery storage will be installed in the central heating plant. The batteries will be purchased in a self-contained unit and installed in a stacked manner near the electrical infrastructure. The 3MWh of capacity will provide 1MW of demand response capacity.

There are multiple benefits to the battery storage systems as they can be charged overnight when electricity is both cheap and clean with a lower carbon content than the marginal during daytime operation. The conversion efficiency of the batteries is also very high at over 90%. Containerized solutions provide an advantage for noise mitigation and the ability to relocate generator in future to accommodate relocation of the Central Plant and/or Nodal Plant Design.

Objectives Supported

- *No material impact to utility budget*

Principals Applied

- *Reach beyond our own assets*
- *Foster innovative solutions*

Scope of Work:

Supply a containerized BESS solution 1MW @ 3 hours (3MWh) batteries with required HVAC, controls, etc.



Nodal Plant Option

This option has been omitted from the report as it may no longer be applicable.

MC-ECM-04: Combine Elect Service and Upgrade (+3MW)

a) Overview

As part of our strategy to electrify McCaul’s 3 buildings we’re proposing to change from the current Class B to a Class A rate. By electrifying the heating to electric should put us into the 1000kW minimum demand threshold for Class A. In addition, we would be required to tie all three buildings together electrically to achieve the new rate Class A.

The measure is in line with the overarching Nodal Strategy that our electrical service group has been taking elsewhere on campus. It allows for larger targeted demand response items for any storage systems on the node, which may indeed have a carbon effect since they will typically be used on peak days when the grid has a likely higher concentration of CO2/kW as the gas-fired plant dispatched for generation.

Based on preliminary load sizing we expect there to be another 1.7MW of peak electric load. When combined with existing 0.8MW we would require approx. 3MW in total. We’re proposing to build a customer owned HV substation service, consolidating the three existing buildings, proposed thermal (electric if decided) loads, and any future loads such as the Steward building. Other considerations include the renewal of the HA/EX/OA LV main electrical distribution systems, and emergency generators from diesel to renewable nature gas.

Objectives Supported

- *Build resilient low carbon systems*
- *No material impact to utility budget*

Principals Applied

- *Balance carbon with cost*
- *Reach beyond our own assets*
- *Foster innovative solutions*



Nodal Plant Option

This option has been omitted from the report as it may no longer be applicable.

MC-ECM-05: Electrify DHW

a) Overview

Three gas fired domestic hot water heaters provide domestic hot water (DHW) for the buildings EX and OA. The DHW heaters are in the boiler room.

We're proposing to install new 60-kW electric DHW boiler in HA basement mechanical room and feed 2 x DHW tanks.

Nodal Plant Option

This option has been omitted from the report as it may no longer be applicable.

Objectives Supported

- Build resilient low carbon systems
- Eliminate CO2
- Carbon tax avoidance

Principals Applied

- Balance carbon with cost
- Foster innovative solutions

MC-ECM-06: Upgrade BAS + DCV and Recommission in HA

a) Overview

The mechanical systems and their control equipment are in generally good condition but are now over 15 years old and would benefit from this measure.

- JCI NAE controllers @ 3 are overloaded controllers (>120%)
- JCI access via launcher.

This may entail upgrading of existing DDC points and addition of some new DDC points to allow the systems to follow the building loads more closely. The BTU meters which have not been working properly in the past two years for heating and cooling BTU meter is required to be calibrated, and re-commissioning.

- Upgrade BAS and connect to EBI for control

b) Economics and Other Benefits

Only utility savings have been included at this stage. We will need to understand what the differential operating costs are during the next detailed engineering phase.

Objectives Supported

- Eliminate CO2
- Address deferred maintenance
- Carbon tax avoidance

Principals Applied

- Conservation first
- Foster innovative solutions
- Improve comfort and wellness

ECM ID	Electrical Savings	Thermal Savings	Saving Totals
--------	--------------------	-----------------	---------------



	kW ^{DR}	kW ^{GA}	kW ^{Pk}	kWh	tCO ₂ e	\$	MMBtu	tCO ₂ e	\$	tCO ₂ e	\$
MC-ECM-06	0	0	0	61,003	2	\$1,806	2,827	212	\$86,450	214	\$88,256

c) Calculation Methodology

To be provided.



d) Constructability

No issues identified at this stage.

MC-ECM-07: Upgrade BAS + DCV and Recommission in EX

a) Overview

The mechanical systems and their control equipment are in generally good condition but are now over 15 years old and are recommended for upgrade. ALC BAS. local access only.

This may entail upgrading of existing DDC points and addition of some new DDC points to allow the systems to follow the building loads more closely. The BTU meters which have not been working properly in the past two years for heating and cooling BTU meter are required to be calibrated, and re-commissioning.

- Upgrade BAS and connect to EBI for control

Objectives Supported

- Eliminate CO2
- Address deferred maintenance
- Carbon tax avoidance

Principals Applied

- Conservation first
- Foster innovative solutions
- Improve comfort and wellness

b) Economics and Other Benefits

Only utility savings have been included at this stage. We will need to understand what the differential operating costs are during the next detailed engineering phase.

ECM ID	Electrical Savings						Thermal Savings			Saving Totals	
	kW ^{DR}	kW ^{GA}	kW ^{Pk}	kWh	tCO2e	\$	MMBtu	tCO2e	\$	tCO2e	\$
MC-ECM-07	0	0	0	33,844	1	\$1,002	158	12	\$4,822	13	\$5,824

c) Calculation Methodology

We have calculated savings based on a conservative 15% reduction of the HVAC loads as per the Energy Balance.

d) Constructability

Costing is based on previous BAS retrofits at the university. We will install this measure in many areas of the facility including in academic areas so that requires careful coordination. We will create a detailed communication and delivery plan due to the nature of this installation before work commences.



MC-ECM-08: Upgrade BAS + DCV and Recommission in OA

a) Overview

The mechanical systems and their pneumatic control equipment are in fair conditions locally, but they are not connected with any central energy management system. It is recommended that this BAS be connected to the central ERMS and building re-commissioning activities, such as system tune-up, setpoint calibrations, control sequence re-adjustment, and preventative maintenance corrections, etc., be performed.

Meanwhile, M&V&T program follows IPMVP protocol as a guidance, the savings can be properly quantified and accounted. The ongoing Cx activity ensures the persistent savings to be maintained over the time.

- Upgrade BAS and connect to EBI for control

Objectives Supported

- Eliminate CO2
- Address deferred maintenance
- Carbon tax avoidance

Principals Applied

- Conservation first
- Foster innovative solutions
- Improve comfort and wellness

b) Economics and Other Benefits

Only utility savings have been included at this stage. We will need to understand what the differential operating costs are between existing operation and proposed during the next detailed engineering phase.

ECM ID	Electrical Savings						Thermal Savings			Saving Totals	
	kW ^{DR}	kW ^{GA}	kW ^{PK}	kWh	tCO2e	\$	MMBtu	tCO2e	\$	tCO2e	\$
MC-ECM-08	0	0	0	12,479	0	\$369	58	4	\$1,778	0	\$2,147

c) Calculation Methodology

We have calculated savings based on a conservative 15% reduction of the HVAC loads as per the Energy Balance.

d) Constructability

Costing is based on previous BAS retrofits at the university. We will install this measure in many areas of the facility including in academic areas so that requires careful coordination. We will create a detailed communication and delivery plan due to the nature of this installation before work commences.



MC-ECM-09: Install Solar PV at HA

a) Overview

The roof of the penthouse has sufficient open area to support a photovoltaic array that would help offset the building's grid electricity usage. Per AMP's study, a total 342 PV panels for 120kWac capacity is proposed to be installed on the roof. The potential energy savings of rooftop solar PV is estimated at 139,725 kWh/annual.

Scope of Work:

- Approx. 342 panels
- 150kW, outdoor rated inverter installed on the roof
- Outdoor rated rapid shutdown box

Objectives Supported

- Build resilient low carbon systems
- Eliminate CO2
- Carbon tax avoidance

Principals Applied

- Reach beyond our own assets
- Foster innovative solutions
- Add renewable content



Figure 27: Proposed PV Layout

- Outdoor rated DC disconnect and combiner
- All local LDC requirements

b) Economics and Other Benefits

Savings are based on displacing the electric usage at the new electric rate. We will need to include operational costs with equipment renewal for invertors for example. This will be detailed in the next phase of development.

ECMID	Electrical Savings					Thermal Savings			Saving Totals		
	kW ⁰ _R	kWGA	kWPK	kWh	tC02e	\$	MMBtu	tC02e	\$	tC02e	\$
MC-ECM-09	0	75	0	139,725	4	\$4,136	0	0	\$0	4	\$4,136

c) Calculation Methodology

Savings are based on AMP's study.

d) Constructability

Costing is based on typical rooftop installations with no added structural requirements. Systems can be scaled and/or removed if costs for structural prove prohibitive. We will need an approved parallel grid connection from Toronto Hydro.



MC-ECM-10: Install Solar PV on OA

a) Overview

According to the site situation and roof conditions, a small solar PV project is recommended based on a RETScreen Expert analysis. It is proposed to install 15kW of Solar PV on the roof of OA.

Scope of Work:

- 30kW, outdoor rated inverter installed on the roof
- Outdoor rated rapid shutdown box
- Outdoor rated DC disconnect and combiner
- All local LDC requirements

Objectives Supported

- Build resilient low carbon systems
- Eliminate CO2
- Carbon tax avoidance

Principals Applied

- Reach beyond our own assets
- Foster innovative solutions
- Add renewable content

b) Economics and Other Benefits

Savings are based on displacing the electric usage at the site based on synchronous grid operation.

ECM ID	Electrical Savings					Thermal Savings			Saving Totals		
	kWDR	kWGA	kWPk	kWh	tCO2e	\$	MMBtu	tCO2e	\$	tCO2e	\$
MC-ECM-10	0	9	0	16,900		\$500	0	0	\$0		\$500

c) Calculation Methodology

Savings are based on RETScreen for Toronto.

d) Constructability

Costing is based on typical rooftop installations with no added structural requirements. Systems can be scaled and/or removed if costs for structural prove prohibitive. We will need an approved parallel grid connection with Toronto Hydro.



MC-ECM-11: Upgrade Heating Radiators in OA

a) Overview

The perimeter radiant heating system (units and piping included) are approaching end of life. It is proposed to replace with new more energy-efficient models. The retrofit will require the system to connect and be designed with the LTHW system (135°F) and maintaining the same heating output, fan coil units appear to be a suitable alternative to the original units.

The additional opportunity of energy savings is controllability on the individual unit through temperature reset and occupancy sensing. There are approximately 24 units per floor for 5 floors, giving a total of 120 units for the entire building requiring conversion. Each unit has an output of 600 btu/ft/hr with a length of 4ft, providing 2400 btu/hr. An equivalent output of fan coil unit should be sized to replace each of the existing radiant units.

Nodal Plant Option

This option has been omitted from the report as it may no longer be applicable.

Objectives Supported

- *Address deferred maintenance*

Principals Applied

- *Foster innovative solutions*



UNIVERSITY OF TORONTO

Climate Positive: 500
University Deep Energy
Retrofit Proof of
Concept Report

External Version

April 8th, 2022



Table of Contents

1.0	Executive Summary	4
1.1	Overview	4
2.0	Building Systems Discussion:	8
2.1	Building Mechanical systems:	8
2.2	Electrical System:	13
2.3	Water System:	14
3.0	Building Performance Analysis.....	15
3.0	Detailed Proposed Energy Conservation Measures:.....	17
3.1	ECM-01 Heating Plant Electrification	18
3.2	ECM 02 – Lighting Upgrade	21
3.3	ECM 03 – Building Automation System (BAS).....	21
4.0	Deferred Maintenance Items not addressed in the proposed ECMs package:	22
4.1	Cafeteria AHU:	22
4.2	Emergency Generator:	22
4.3	AHU Interior Supply Duct Air Leak:	23
5.0	Low Carbon Action Plan.....	23
6.0	Mandatory Requirements	24
6.1	Outcomes / Performance Metrics.....	24
6.2	U of T Design Standards	24
7.0	Financial Analysis	26
	Appendix A – AHU controls diagrams snapshots	27
	Appendix B – Existing Conditions and Proposed ECM Measures Schematic.....	33



ABBREVIATIONS

AHRI	Air Conditioning, Heating and Refrigeration Institute
AHU	Air Handling Unit
ASHRAE	American Society of Heating, Refrigerating and Air-Conditioning Engineers
ASME	American Society of Mechanical Engineers
ATS	Automatic Transfer Switch
BAS	Building Automation System
BAU	Business as Usual
CFM	Cubic Feet per Minute
CHW	Chilled Water
CMMS	Computer Maintenance Management Systems
CMRS	Central Management and Reporting System
COP	Coefficient of performance
CW	Condenser Water
DHW	Domestic Hot Water
EMRS	Energy Management and Reporting System
GA	Global Adjustment
GSHP	Ground Source Heat Pump
GPM	US Gallons per Minute
HTHW	High Temperature Hot Water
lbs/hr	Pound per Hour (Steam Flow Rate)
IESO	Independent Electricity System Operator
LDC	Local Distribution Company
LTHW	Low Temperature Hot Water
MSB	Medical Sciences Building
TH	Toronto Hydro
THESL	Toronto Hydro Electric System Limited
UMP	Site Utility Master Plan
UPS	Universal Power Supply
VFD	Variable Frequency Drive



UNIVERSITY OF
TORONTO

Facilities & Services



1.0 EXECUTIVE SUMMARY

1.1 Overview

In recognition that climate change remains one of the most pressing challenges of our time, the University of Toronto St. George campus has committed to becoming climate positive (having net negative emissions) by 2050. Our downtown Toronto campus—the university’s largest and oldest campus—makes up over 80% of the University of Toronto’s operational carbon footprint. Our impact on the institutional footprint and our key role in the community calls for going beyond net-zero carbon emissions to become climate positive by 2050. This means not only reducing the operating emissions under our control, but also mitigating additional carbon emissions to achieve net-negative emissions,

Our first step towards becoming climate positive is to invest in transformational infrastructure renewal as part of our 30-year carbon and energy campus master plan. We are moving towards a renewed, resilient and reliable utility infrastructure that will enable our campus to operate and thrive without disruption and mitigate the impacts of growth on our carbon footprint. Our 2050 plan follows the release of U of T’s tri-campus Low-Carbon Action Plan (2019-24), which focuses on U of T’s 2030 reduction target, and will position the institution to accelerate carbon reductions towards 2050.

While proud of our 2050 plan and commitment, we realize that we need to take decisive action now. As part of the launch of the Climate Positive Campus plan, the University is launching Deep Energy Retrofit Projects across campus to eliminate gas as a primary fuel for heating, and switch to low temperature hot water heating systems. In addition, optimizing ventilation, lighting retrofits, and adding renewable energy assets where possible while renewing aging assets.

The University of Toronto Energy Management team has conducted an energy audit of 500 University and identified key Energy Conservation Measures (ECMs).

500 University is a 13,091 m², 10 storey building located at University Avenue and Edward Street, 2 blocks South of University of Toronto St. George main campus. The building houses the Rehabilitation Sciences School and consists mainly of classrooms, large lecture halls, dry labs, and one wet lab.

Being an off-Campus building, it is not connected to the St. George Campus District Energy Systems (DES). The building was built in 1958 and was known as the Mutual of Omaha building at the time. Originally it was equipped with 2 gas fired boilers for heating the core fresh air supply and Domestic Hot Water while the perimeter heating was supplied with Dunham Baseboard Convectors. Air conditioning was supplied with dedicated AC units and a cooling tower.

500 University Key Objectives

- *Elimination of 432 net metric tonnes of CO₂, representing 80% of the annual Scope 2 thermal emissions*
- *No material impact to the building’s utility budget*
- *Added energy system resiliency by having dual fuel capability*
- *Addresses significant deferred maintenance priority*



Two duct shafts run along the height of the building near the elevator shaft that house the interior air supply and main return air ducts. The bulk of the fresh air supply is introduced by the interior AHU handling unit with a total volume of 60,000 CFM. The perimeter fan delivers 18,900 CFM to induction units while the main return fan has a maximum volume rate of 70,000 CFM.

1991 Retrofit

In 1991, the building was equipped with electric duct heaters/reheat coils. At that time the perimeter heating had been already converted to induction units heating fed by the gas fired boilers in the penthouse mech room. Several Exhaust fans were also installed. A Carrier AHU (AC-1 AHU – Mixed air) with hydronic cooling and heating coils was installed in the cafeteria which remains. A carrier split system was installed in the kitchen (AC-2 133 MBH). A Carrier chilled water fan coil unit was installed in the lobby (AC-3 27MBH). A TRANE hot water heating unit was also installed in the Mechanical room (EHT-1 17.4 MBH). Electric heating units were installed in the shipping area (EHT-2 5KW) and two in the kitchen (EHT-3 & 4 2KW each) as well as several exhaust fans. Thermostats were installed throughout the building controlling all newly installed equipment including electric heaters, duct reheat units and induction units.

2002 Retrofit

In 2002, hot water source for heating loads was changed from gas boilers to steam converters (Heat Exchangers). The steam to hot water heat exchangers were located in a basement mechanical room and fed the original main header in the penthouse mechanical room. CVBs with basic air volume controls were installed throughout the building.

Retrofits to the AHUs and DHW were done since 2002 but no major changes to the building's energy systems were made. More details on the changes are in section 2.0.

No assessment of the building's air leakage rate is available. The building has single glazed windows that are believed to be original to the building. With reference to the baseline year used in this report 2018/2019, it has a TEUI of 360.80 ekWh/m².y, GHGI of 44.86 Kg CO₂e/m².y, and the building emits just over 587 tons of GHG annually, primarily scope 2.

Benchmarking

Considering that 500 University is primarily an office building with very few dry labs, the recommended target TEUI according to ASHRAE 100 should be 287 ekwh/m² (source energy (Table 7-2b, ASHRAE 100-2015) and 314 ekwh/m² according to NRCAN 2014 survey of office buildings (non-medical).

Proposed Energy Conservation Measures Overview:

The University of Toronto Energy Management team conducted an energy audit of the Faculty of Rehabilitation Sciences building and identified key Energy Conservation Measures (ECMs).

The goal of the ECMs identified is to demonstrate that the Deep Energy Retrofit program targets of reducing the GHG emissions by 80% and EUI by 40% can be achieved, and initiate a discussion for improvements and new innovative measures in the next stages of the project.



The ECMs selected are decarbonizing the steam heating plant by electrifying heating using a combination of electric boilers and heat pumps with gas fired boilers for peaking.

The building is estimated to exhaust approximately 22,000 CFM of conditioned air based on AHUs specs and OA intake field observations. The exhaust air is primarily accessible through main exhaust fans presenting an opportunity for heat recovery as a source of low-grade heat for the proposed water source Heat Pumps loop. Additional opportunity for feeding the space heating loop is attainable through replacing excess OA intake by the AHU-interior unit for free cooling with mechanical cooling using heat pumps. The space heating electrification ECM is expected to result in a net GHG reduction of ~416 tons or 71% of the building's total emissions, in addition to a 59% reduction in heating energy intensity.

A lighting retrofit is proposed to reduce the lighting energy consumption by 55% and 13 tons of Carbon or 2%. This retrofit will target replacing the T8s and CFLs lamps with LED lighting and lighting controls where feasible.

A Building Automation System (BAS) ECM is proposed that will see integrating the existing VFD controlled fans and VAVs into a single system that is BACnet compatible and complies with the university's controls standard. The measure aims to implement a control strategy that will take advantage of the VFD drives of the AHUs supply fans and return fan, in addition to utilizing the modulation capability of the VAVs (referred to in the mechanical drawings and this report as CVBs).

Finally, critical deferred maintenance items that will contribute to the energy efficiency of the building were selected. The Deferred maintenance items are replacing the cafeteria AHU and emergency generator that are approaching end of life. The emergency generator replacement DM measure proposes switching from Diesel to Gas supported by the availability of an express gas line that runs to the penthouse mechanical room close to the roof mounted emergency generator.

Proposed measures summary

The proposed conceptual ECMs are expected to meet the project's KPIs and result in a projected reduction in utilities cost in year 1 of ~\$171K based on 2022/2023 utility rates. The proposed measures are expected to achieve a TEUI of 231 ekwh/m².y or 36% reduction and a GHGI of 12 KG CO₂e/m².y. or 73% reduction. While the estimated TEUI and GHGI values don't meet the Project Charter and Project targets, they demonstrate that with refinement of the proposed measures, or an alternate more innovative approach, the targets can be achieved or exceeded.

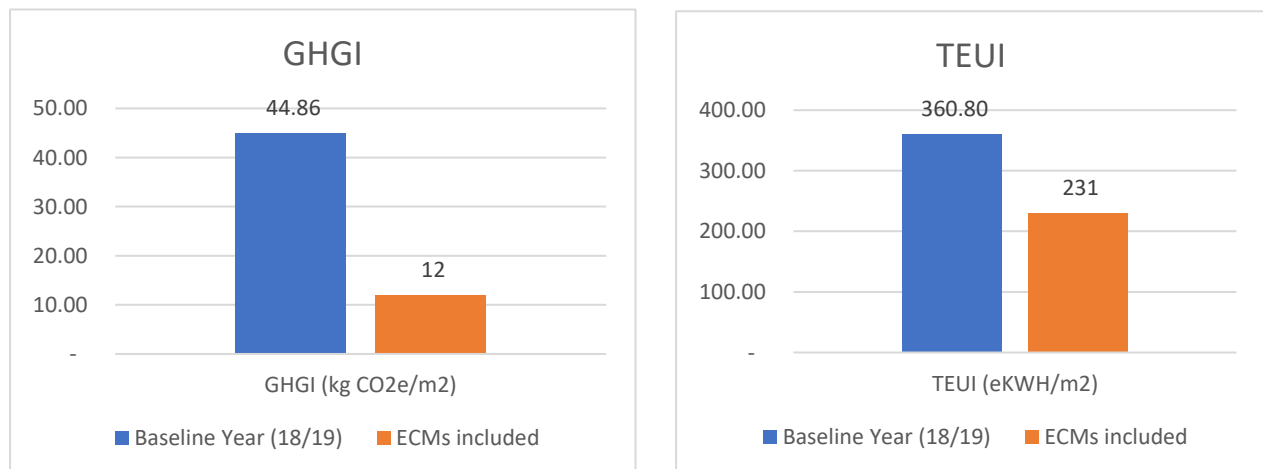

Figure 1 Energy metrics summary



Table 1 Summary of ECMs

ECM #	Location	Description	Measure	Outcome
RS-ECM-01	Basement and Penthouse Mech room	Heating Plant Electrification	Heat Pumps – 150 Tons with Gas Boilers for trim	Reduce the total GHG emissions by 70% (415 net Metric Tonnes)
RS-ECM-02	All Floors	Lighting Retrofit	Lighting: Re-lamp with LED lighting and implement lighting controls	55% saving on lighting energy – 328 MWH/year
RS-ECM-03	Full Building	Building Automation System (BAS)	Optimize ventilation, pumps, CVBs and fans controls	Advance the building towards full automation
RS-DM-01	Mech room 116	Cafeteria-AHU replacement	Deferred maintenance item: Replace the existing Cafeteria-AHU with new AHU equipped with VFD motors and DCV to integrate into new BAS system	Address a critical deferred maintenance item
RS-DM-02	Roof	Emergency generator replacement	Deferred maintenance item: Replace the existing Kohler Diesel generator with a 150 KW Gas fired emergency generator	Address a critical deferred maintenance item
RS-DM-03	Penthouse mech room	Repair and seal return duct to AHU-Interior	Deficiency repair item: Repair and seal supply duct to AHU-Interior	Address a deficiency

Table 2 Summary of ECMs - Units and Savings

ECM ID	Electrical Savings			Thermal Savings			Total Savings	
	KWH	tCO2e	\$	MMBTU	tCO2e	\$	tCO2e	\$
RS-ECM-01 Electrification of Heating	- 671,091	- 27.51	- 84,738.86	6,366.19	442.16	207,620.18	414.64	122,881.31
RS-ECM-02 Lighting Retrofit	328,041.24	13.45	41,421.87				13.45	41,421.87
RS-ECM-03 Building Automation & DCV	60,653.69	2.49	7,658.76				2.49	7,658.76
RS-DM-01 Cafeteria AHU								
RS-DM-02 Emergency Generator								
RS-DM-03 Air leak repair								
Sum	- 282,396.05	- 11.58	- 35,658.24	6,366.19	442.16	207,620.18	430.58	171,961.94



2.0 BUILDING SYSTEMS DISCUSSION:

2.1 Building Mechanical systems:

Heating capacity is supplied by Two steam to hot water heat exchangers HE-1&2. The water is supplied at 180 DEGF @ 15psi at the header (EWT 150 DEGF - LWT 190 DEGF).

Heat Exchanger HE-1 is typically on standby. the heat exchangers have a total maximum capacity of 7,400 lb/hr ~ 7.4 MMBTU (~7400 MBH).

The Hot Water from the steam to water heat exchangers located in the basement mechanical room feed all the main loads by supplying the hot water to the header located in the penthouse mechanical room.

The header feeds the following loads:

- Hot water to Glycol heat exchanger supplying hot Glycol for heating coil supply fan SF-1 providing the main fresh air supply AHU (AHU-interior) to the building and located in the mechanical penthouse.
- Hot water to Perimeter ventilation AHU (AHU-Perimeter) heating coil
- Hot water to Perimeter induction units water loop/riser
- Hot water to Washroom heaters
- Hot water to Ducts heating loop/riser feeding CVB reheat coils
- Hot water to Ground floor and lobby units
- Hot water to NE and SE Baseboard heaters
- Hot water supply to the Multi-purpose room AHU unit (AHU-1) heating coil
- Hot water supply to the Cafeteria/Lobby AHU unit (AC-1)

The summer and winter sequence initially intended to allow for pump backup is disabled – P-8 does not backup P-9 in the winter and P-9 does not backup P-8 in the summer.

Humidifier H-1 is a gas fired humidifier serving the interior AHU. The humidifier is not operational, and no humidification is currently supplied to the building.

The chiller plant is a dual compressor 300T McQuay Chiller. The chiller plant runs at about 50% capacity at peak cooling demand and feeds both AHUs cooling coils as well as the induction units water loop, multi-purpose room, and cafeteria. The Chiller is served by a new cooling tower on the 10th floor roof.

A roof top chiller is installed intended to serve AHU-interior was found not operational.

The perimeter and interior units have a common return fan 70,000 CFM and a common fresh air Louvre and plenum with each unit having a dedicated OA damper

Domestic hot water is provided by a Rheem-Ruud Universal 250MBH Natural gas 80% efficiency boiler and a 119 USGAL tank. DHW was supplied via 2 DHW tanks in the penthouse in 2002.



Both main supply fan SF-1 of the interior AHU (AHU-interior) and main return fan RF-1 are equipped with VFD drives.

Lighting is primarily a mix of T8s and, CFLs and recessed lights on most floors.

Ventilation System (Airside) Summary:

Multi-purpose room AHU-1 unit installed on the Ground floor:

Supply Fan - 5 HP (4000 CFM – Max Fresh Air 1600 CFM)

Return Fan RF-2 – 3600 CFM

HC: Water Heated coil - 200 MBH – 1 row (12 FPI)

EAT 40F LAT: 82 / EWT: 180F LWT: 160F@20 GPM

CC: Water cooled – 177 MBH – 5 rows (9 FPI)

EAT 83/68F LAT: 55/54 / EWT: 45F LWT: 55F@36 GPM

Ceiling Air AC-1 DX unit located in Room 4-18:

Supply Fan – 0.5 HP -1250 CFM

Condensing Unit Fan – 0.5 HP -1650 CFM

Interior AHU unit (in Mech penthouse):

Main Supply Fan - 75 HP - 60,000 CFM (VFD with CO2 sensor installed 2002)

HC-1: Glycol Heated coil - 2030 MBH (1 row – 11 FPI)

EAT 33F LAT: 57 / EWT: 150F LWT: 130F@172.8 GPM

CC-1: Water cooled - 1600 MBH (6 rows – 10 FPI)

EAT 60F LAT: 50 / EWT: 40F LWT: 52F@279 GPM

Perimeter unit (installed in Penthouse):

Supply Fan – 40 HP, 27.3 BHP, 25% min. OA, 18,900 CFM (installed in 2013)

HC: Water Heated coil – 613 MBH EAT 53F LAT: 82 / EWT: 160F LWT: 160F @ 58 GPM

CC: Water cooled EAT – 668 MBH (478 MBH sensible) 79/66F LAT: 54.9/53.6 / EWT: 42F @ 132 GPM

Main return fan (in Mech penthouse):



Fan: RF - 30 HP - 70,000 CFM

Feeds both AHU units.

Kitchen AHU (in room 116):

Carrier unit serving the kitchen

Supply and return fans. Served by the 300T chiller.

Return fan equipped with a damper allowing mixed air capability.

The AHU is equipped with a heating coil.

Terminal Constant Volume Fan Powered Boxes:

All terminal units are Tuttle & Bailey and equipped with a single row hot water coil and have a discharge capacity ranging from 200 to 1300 CFM.

Exhaust Fans:

Table 3 Exhaust Fans Summary

Fans	CFM
EF-1	150
EF-2	1000
EF-3	150
EF-4	100
EF-5	150
EF-6	150
EF-7	300
EF-8 (Fume Hood)	735
EF-9	900
EF-10	1000

2.1.1 Peak demand and baseload

Steam – Space Heating:

Based on the Steam utility bills, the peak monthly steam consumption 1,090,000 lbs (~1,301 MMBTU) for the month of Dec, 2017. Based on a regression analysis of the baseline year plotted against HDH, an estimate peak load of 2.35 MMBTU/HR and an average hourly load of 1.29 MMBTU/HR was estimated. The same analysis revealed that space heating loads are below 1.8 MMBTU/HR for 94% of the time. The



hourly analysis calibration to monthly bills showed higher error in the shoulder seasons and lower error 3 to 13% during the heating season.

The steam is supplied at 200 psi to the building and dropped to 100 psi before reaching the Steam to HW heat exchangers.

A regression analysis of the baseline year revealed a monthly baseload of ~239 MMBTU and is assumed to be the summer reheat load since steam is not used in the building for any other application other than space heating.

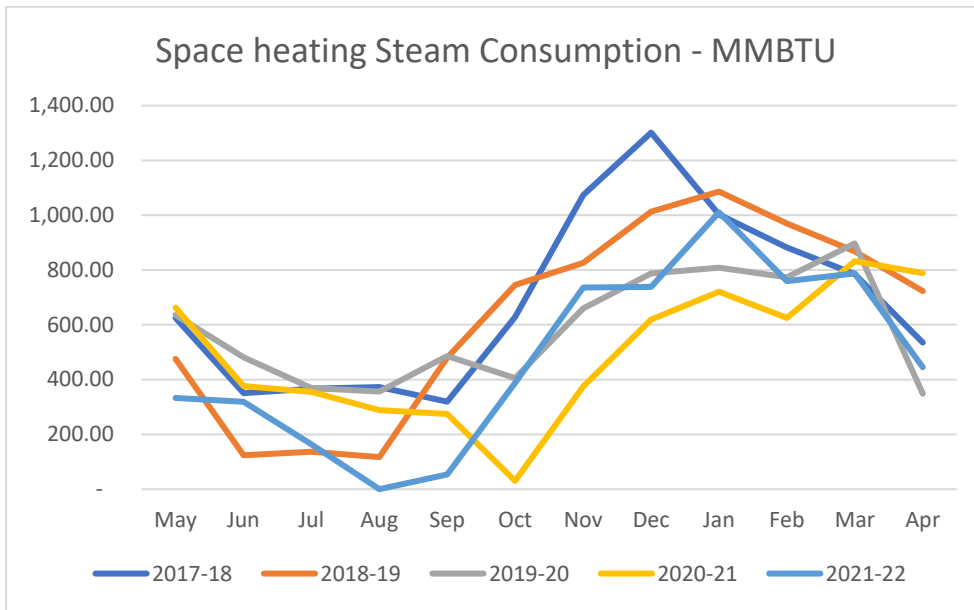

Figure 2 Space Heating Consumption profile

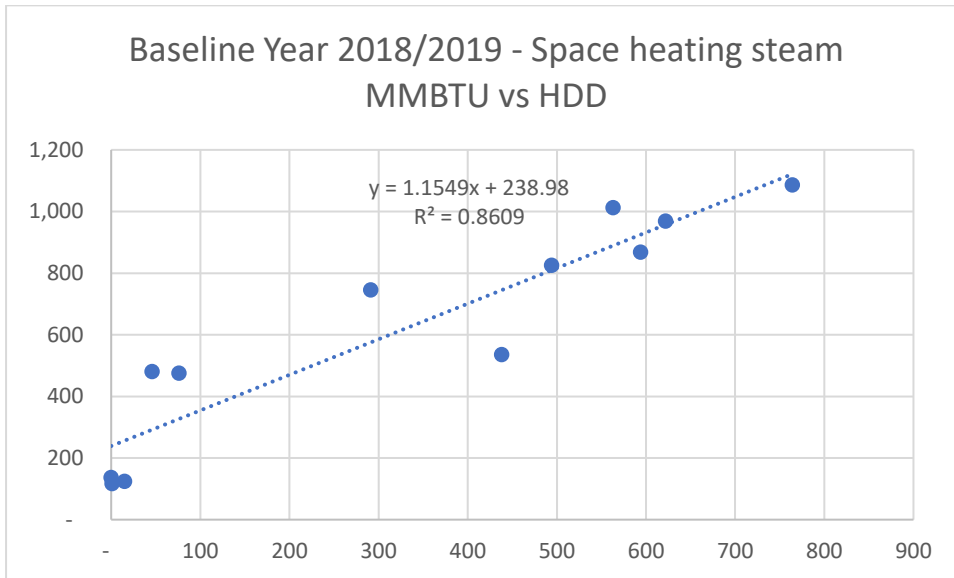

Figure 3 Space Heating - Steam Regression Analysis of Baseline Year

Gas – DHW:

Gas is used primarily for DHW. The express gas line that runs to the Penthouse mechanical room was originally used to feed the two dual fuel boilers that were retired and replaced by third party steam for space heating in 2002. The line now feeds only the Rheem water heater in the penthouse mechanical room. Gas monthly consumption average is ~400m3.

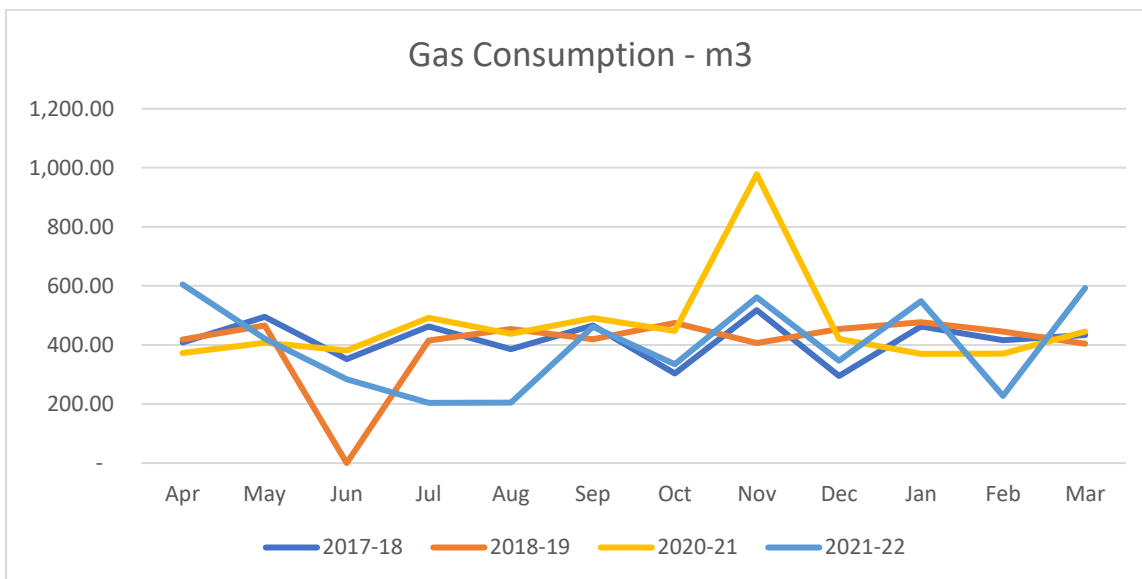

Figure 4 DHW - Gas Consumption Profile



2.2 Electrical System:

The building is hydro connected and served by a 13.8 KV service feeding 2 x 1,000 KVA (13.8KV to 120/208V) transformers. The Main switchboard is a 4,000 A 3P split bus and receives 120/208V from the transformers secondary.

TX2 transformer and bus serve the risers with a 2,400A main breaker, the 150T chiller splitter, cooling tower fan, AHU-interior supply fan and penthouse panel P1.

TX1 transformer and bus serve the other loads including penthouse MCC, panel DP-DPA, fire pumps, penthouse other life safety and elevators ATS loads, pump control panel, RP-GH, 120KVAR capacitor bank, panel BA, RP-GC, basement MCC, and main 300T chiller.

Emergency power is provided through a 150kW, 120/208V generator.

With reference to the baseline year, electrical consumption peaks in the summer at ~274 MWH and Peak demand of ~500 KVA or 50% of one transformer capacity.

A regression analysis of the baseline year revealed a baseload of ~185 MWH.

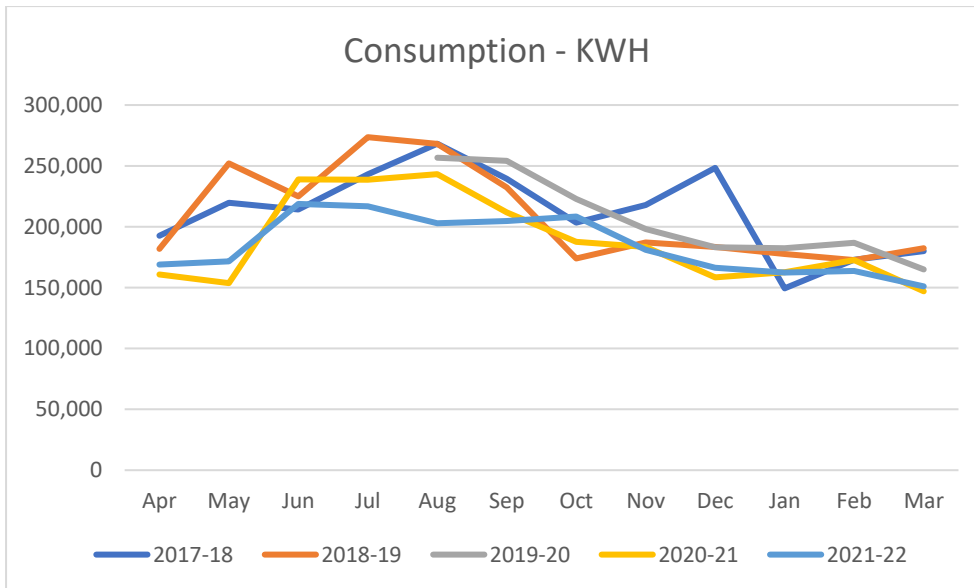

Figure 5 Electrical Consumption Profile

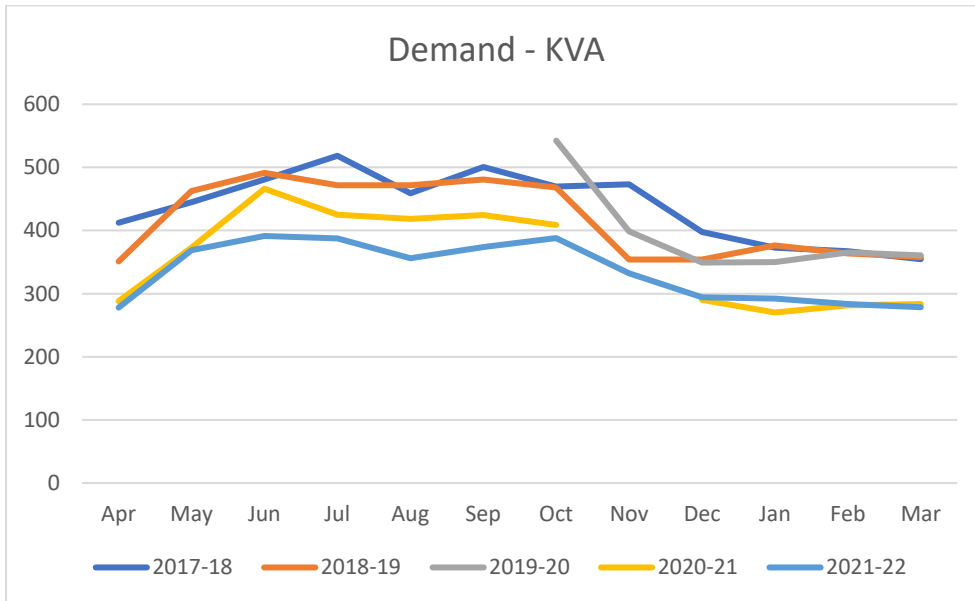

Figure 6 Electrical Demand Profile

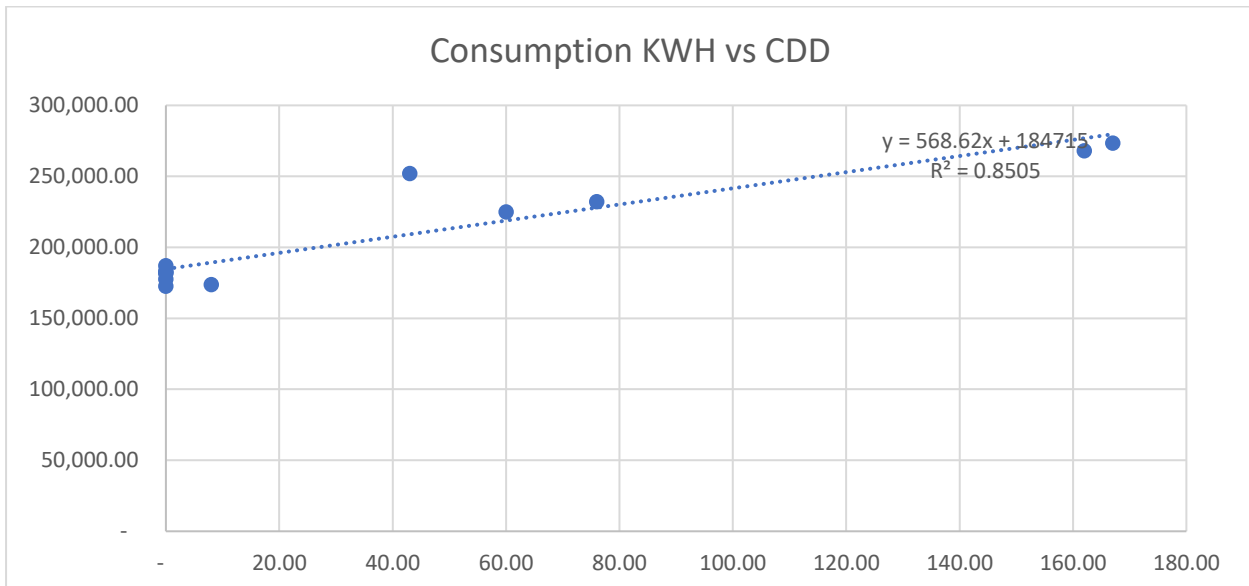

Figure 7 Electrical Consumption Regression Analysis

2.3 Water System:

The water consumption follows a pattern of increasing consumption in the summer months by 2.4 times compared to the winter months with reference to the baseline year. The consumption increase coincides with the cooling season and is likely attributed to the cooling tower evaporation volume. A new cooling



tower was installed in 2022 and an updated set of data from 2022-2023 would be more representative of current consumption, and possible opportunities to reduce the cooling tower consumption further.

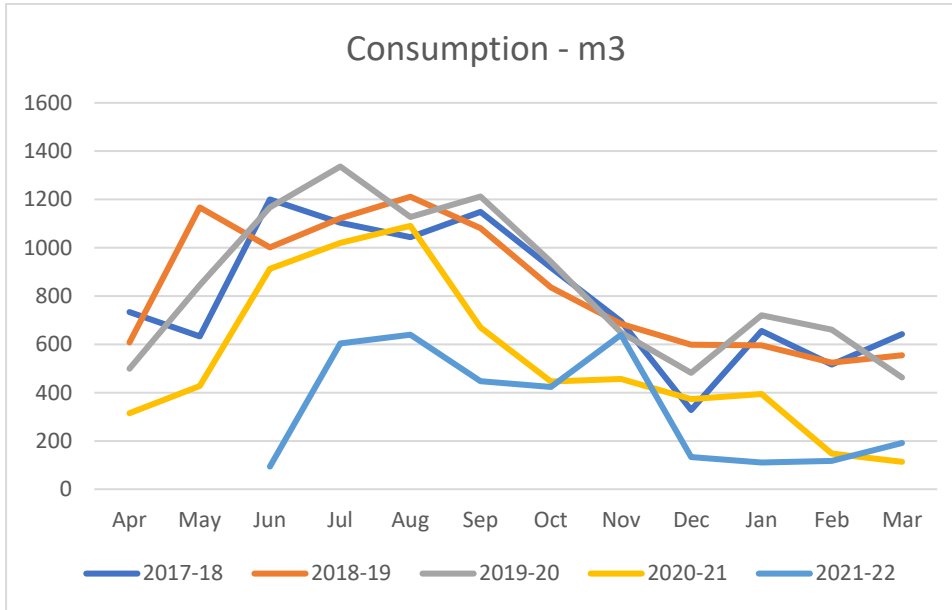

Figure 8 Water Consumption Profile

3.0 Building Performance Analysis

The building's TEUI (Total Energy End Use Intensity) is higher than the average office building, it is currently at 360 eKWH/m2 as mentioned in the benchmarking discussion. The higher TEUI could be attributed to the age of the building envelope which is built less airtight and insulated compared to an average modern building, close to constant air volume configuration, and older lighting fixtures. The GHGI is 44.86 kgCO_{2e}/m², equivalent to 587 tons of GHG per year which is mainly scope 2 and attributed to purchased third party steam.

Table 4 Building Performance Metrics Summary

Energy Metric	Units
TEUI (kWh/m2.yr)	360.80
TEDI (kWh/m2.yr)	169.07
GHGI (kgCO _{2e} /m ²)	44.86

Energy End-use breakdown:

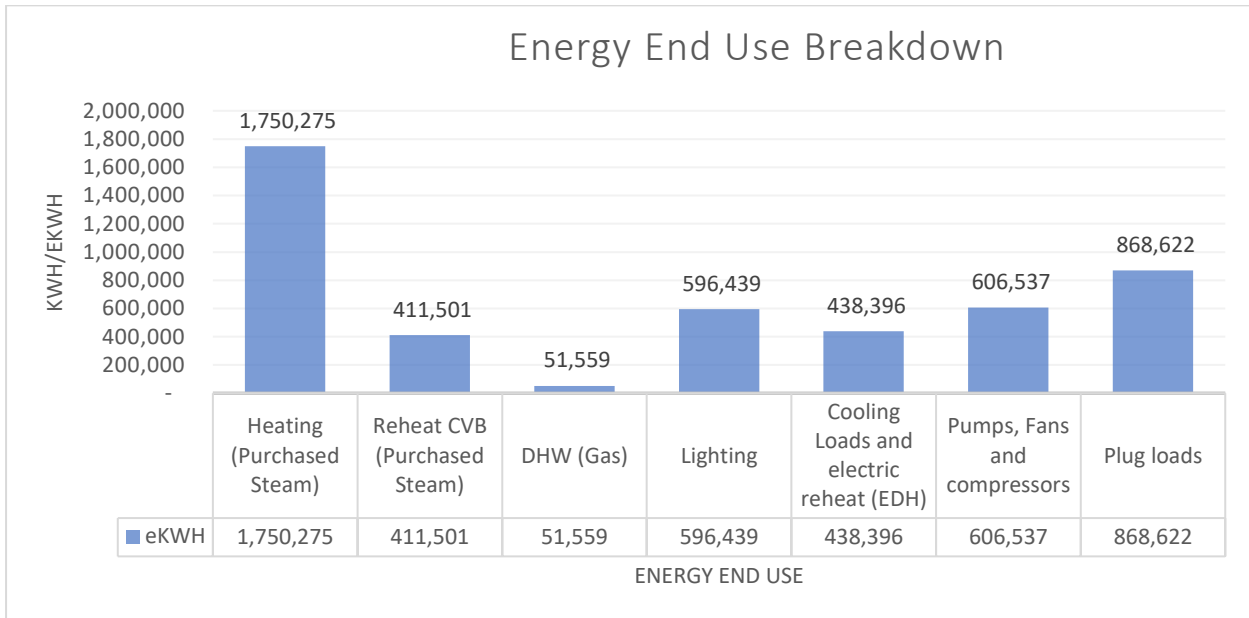

Figure 9 Energy End Use Breakdown

The energy end use breakdown shows that space heating is the highest energy load representing 37% of the total annual energy consumption. A summer reheat load represents 9% of the total annual energy consumption. Together the total annual heating energy represent 46% of the total annual energy consumption and 81% of the building's emissions or 475 tons.

High lighting loads are typical in commercial buildings. The lighting load is the fourth highest energy end use and represents 13% of the total annual energy use and 24 tons annually of Carbon.

Rates Structure:

500 University is off the main campus and is fed by Toronto Hydro and Enbridge for gas. Steam is supplied by third party and delivered to the loads as hot water via onsite steam to hot water heat exchangers. The gas rate has significantly increased in the second half of 2022 through the cost adjustment charge resulting in an average annual blended rate of just over \$0.58. The blended rate includes the Federal carbon tax charge. Third party steam unit rates have increased in the last fiscal year bringing the blended rate to \$29.47 in the year 2021-2022. The blended rate includes the Federal carbon tax charge. The blended average rate of electricity is \$0.126/KWH and the building is a class B customer with a peak of ~500 KVA (baseline year).

The utilities blended rates and emissions rates below were applied to the selected baseline year 2018-2019 fiscal year to calculate the savings of the proposed ECMs. The baseline is a pre-COVID year and is considered representative of future energy demand.



Table 5 Utilities Rates and Emissions values

Utilities Rates			Emissions	
Hydro Blended Rate	0.126	\$/Kwh	41	gCO2e/Kwh
Enbridge Gas Unit Rate	0.159	\$/m3	1933	gCO2e/m3
Enbridge Gas Annual Fixed Charges	1,638.64	\$	182	gCO2e/ekwh
Enbridge Carbon Tax rate	0.09	\$/m3		
Enbridge blended rate	0.58	\$/m3		
Enbridge Gas Unit Rate W/O Carbon cost	0.49	\$/m3		
Enbridge annual carbon escalation to 2030	0.03	\$/m3		
Steam Unit Rate	17.07	\$/MMBTU	64,370	g CO2e/MMBTU
Steam Annual Fixed Charges	68,498.88	\$	220	gCO2e/ekwh
Steam Carbon Tax Rate	3.12	\$/MMBTU	76.6	g CO2e/lbs
Steam blended Rate	29.47	\$/MMBTU		
Steam Unit Rate W/O Carbon cost	26.35	\$/MMBTU		
Steam annual carbon escalation to 2030	0.97	\$/MMBTU		
Water	4.48	\$/m3		

The information used to develop our understanding of the existing system are as follows:

1. 500 University renovation project – 01-241
 - a. Drawing M-01 to M-16 – Revision 4 (February 2002)
2. 500 University renovation project – 2001-0485
 - a. Drawing E1-01 – Revision 4 (December 2001)
3. University of Toronto Utilities Division F&S Single Line Diagram
 - a. Drawing 0152-SLD-01 – Revision 01 (February 2023)
4. Rushby Energy Solutions University of Toronto Lighting Audit – Rehabilitation Sciences – (February 2002)
5. University of Toronto EM team Site visit performed on February 08, 2023

3.0 DETAILED PROPOSED ENERGY CONSERVATION MEASURES:

A high-level schematic summarizing understanding of current building systems and proposed ECM01 is attached in Appendix A



3.1 ECM-01 Heating Plant Electrification

This Energy Conservation measure aims to replace the heating plant currently running on third party steam with 150 Tons of Water to Water heat pump capacity as option 1. The proposed capacity will provide the building’s total heating requirements to a temperature of -10 DegC or 1.8 MMBTU/HR. At temperatures lower than -10 DEGC (or >1.8 MMBTU/HR), a Two 1500 MBH gas fired high efficiency boilers will provide heating to the maximum projected annual load of the baseline year 2018/2019 of 2.35 MMBTU/HR. Annually this translates to Heat pump coverage of 6,871 MMBTU (2,013,272 eKWH) or 93% of the total building annual heating demand, including summer reheat. The remaining building demand of 505 MMBTU (147,965 eKWH) or 7% peak demand will be provided by the high efficiency gas boilers. This 93% electrification of the heating plant will result in a net of 415 tCO2e or 70% of the total building CO2e emissions.

The estimated grid emissions used to calculate the electricity (Scope 2) emissions is 41 gCO2e/KWH to reflect Ontario’s projected higher emissions.

The heat pump plant is assumed to operate at an average of 3.0 COP in heating mode utilizing rejected heat from Mechanical cooling of the interior return air and exhaust air heat recovery.

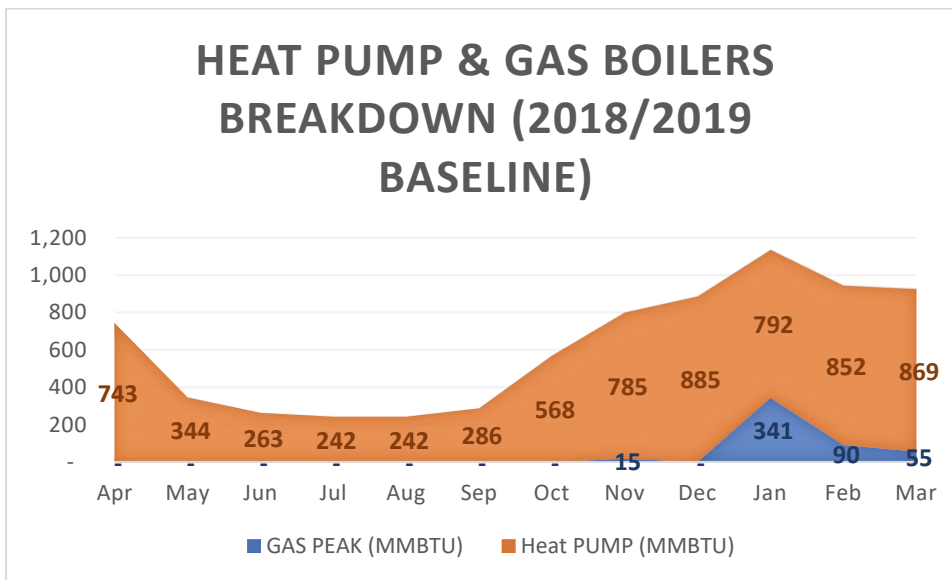

Figure 10 Heat Pump and Backup Gas Boilers Monthly Consumption Breakdown

While the interior unit AHU heating coil is supplied with low temperature hot glycol at 150 DEGF, the perimeter AHU unit receive high temperature water (160 DEGF) directly from the hot water supply header as well as the other loads including the perimeter induction units. A conversion to LTHW may require further investigation of the terminal loads including replacing the perimeter AHU coils.

The building peak demand based on 2018/2019 baseline year is ~500KVA. The available electrical spare capacity is ~450 KVA (95% max loading of a single transformer of the transformer pair). Based on the



data available, 150 Tons of heat pump capacity running as low as 2-3 COP would not significantly load the system beyond the 950 KVA maximum allowed loading.

Further assessment of the summer condition needs to be considered when reheat energy is required by the heat pumps while the chillers are running simultaneously.

Economics and assumptions

The heating plant heat pumps are expected to displace 93% of the total baseline year heating demand while the gas boilers will be used for trimming covering 7% of the baseline year demand.

A second option for implementing this measure contemplates an Air-to-Water heat pump system.

Constructability

In case of option 1 (Water-to-Water heat pump system), the system can be installed in the Penthouse Mechanical room. The LTHW can be connected to the hot water supply header.

In case of option 2 (Air-to-Water heat pump system), 2 locations are proposed, the penthouse mechanical room or an enclosure to house the heat pumps on the roof. The penthouse mechanical room will require re-opening a louvre to provide sufficient outside air flow rate to the Air Source Heat pumps. The LTHW can be connected to the hot water supply header.

The backup gas boilers can be installed in the same locations where the original dual fuel boilers used to be in the penthouse mechanical room and connect to the supply and return headers nearby as well as the original flue stack. A gas connection is available in the mechanical room.

The construction will disrupt the heat supply especially in the final stage when connecting to the existing piping. The final stage of this measure's construction will need to be off the heating season with the final commissioning during the heating season.



3.2 ECM 02 – Lighting Upgrade

A lighting retrofit is proposed to reduce the current LPD by about 55% using a combination of LEDs and lighting controls. This retrofit will need to be planned so as to avoid disrupting the operation in the building. Some stakeholders may wish to test the LED color temperature first before the full installation.

This retrofit is expected to save 328 MWH or 55% of the current 596 MW annual lighting load and eliminate 13.5 tonnes of CO₂e annually.

The building is currently fitted with 4ft T8 32W two lamp fixtures and CFL recessed/pot fixtures.

Lighting controls are absent on all floors, and feasible to implement.

A lighting audit conducted in 2021 by Rushby Energy Services was the basis of the lighting calculations.

Economics and assumptions

Constructability

The lighting audit specifies where occupancy sensors can be installed.

We have assumed the installation work will be done during regular working hours or during low occupancy periods. We propose to install this measure in many areas of the facility including in academic areas so that requires careful coordination. We will create a detailed communication and delivery plan due to the nature of this installation, before work commences.

3.3 ECM 03 – Building Automation System (BAS)

The measure recommends demand control ventilation, BAS optimization, and recommissioning. These include an upgrade to the building automation system as well as attention to building operation including building pressurization. The upgraded BAS will see integrating the existing VFD controlled fans into a single system that is BACnet compatible and complies with the university's controls standard. This measure will convert related pumps to VFD pumps where applicable to fully benefit from the existing VFD fan controls. In addition, to benefit from the supply fans VFD drives, the terminal units CVB boxes, will require controls upgrade to respond automatically to setbacks, and local thermostats. The CVB boxes are currently adjusted manually acting as constant flow boxes. The new BAS system will integrate with the University's EMRS system.

Economics and assumptions

Constructability



CCMS controlled equipment will need to be transitioned to the new BAS system with possible disruption to the equipment operation, such as pumps and fans.

We have assumed the installation work will be done during regular working hours or during low occupancy periods. We propose to install this measure in many areas of the facility including in academic areas so that requires careful coordination. We will create a detailed communication and delivery plan due to the nature of this installation, before work commences.

4.0 DEFERRED MAINTENANCE ITEMS NOT ADDRESSED IN THE PROPOSED ECMS PACKAGE:

4.1 Cafeteria AHU:

The packaged Carrier air handling unit serving the cafeteria and located in mechanical room 116, was installed in 1990 and houses a supply fan, cooling coils and a filter section. The unit has only 5 years of useful life remaining based on 35 years of equipment life.

Photos



Rehabilitation Sciences Building - D304043



Rehabilitation Sciences Building - D304043

Figure 12 Cafeteria AHU - DM

A replacement with demand control ventilation and VFD drive to be integrated into the building's BAS is recommended.

4.2 Emergency Generator:

The Diesel emergency generator located on the roof is a 150 KW unit (188KVA) is in poor condition although no major deficiency was reported. The generator is estimated to have 1 year of useful life left based on a 30 years equipment life.

A conversion to a high efficiency emergency gas generator and the elimination of the diesel storage tanks is recommended. A gas connection is already available on the roof and might need coordination with the other loads to prioritize supply to the generator.



Rehabilitation Sciences Building - D509002



Rehabilitation Sciences Building - D509002

Figure 13 Emergency Power Generator

4.3 AHU Interior Supply Duct Air Leak:

An AHU supply duct suspected air leak near the Pneumatic control panel was observed during the site visit by the university energy manager. The leak is recommended to be addressed by maintenance staff if feasible or as part of the retrofit. Air duct sealing technologies can be used to address this leak.

5.0 LOW CARBON ACTION PLAN

The addition of 500 University retrofit to the U of T Low Carbon Action Plan (LCAP) will contribute 432 tCO₂e reduction or avoidance at a tri-campus level by end of calendar 2024. This contribution supports the U of T in meeting or exceeding its 2030 commitments to mitigate the impacts of climate change thru a 37% GHG reduction relative to a 1990 baseline.



6.0 MANDATORY REQUIREMENTS

6.1 Outcomes / Performance Metrics

The following is a list of performance-based metrics:

- Minimum reduction of 80% of the candidate buildings annual scope 1 & 2 emissions and meet the Project Charter which specifies the Energy Use Intensity (“EUI”) target for each building. The (“**Project Charter**”) defines the energy targets for the projects. Sample Project Charters are found in Appendix D to this RFSQ.
- The utility budget (natural gas, fuel oil, electricity, and water), excluding carbon tax, remains the same or is reduced. Utility rates are fixed to the base year rates.
- Maximize the Net Present Value (“NPV”) using the U of T’s Lifecycle Cost Analysis (“LCCA”) template
- Maximize Greenhouse Gases (“GHG”) reduction
- Project life not to exceed 20 years
- Address Deferred Maintenance (“DM”) on a building-by-building basis
 - Rehabilitation Sciences: Min requirement – Replace the emergency generator
- Perform conversions to low temperature hot water LTHW (<57°C) in support of our Carbon and Energy Master Plan to electrify and decarbonize our campus
- Provide updated as-built drawing sets for all buildings affected
- Provide complete Operations and Maintenance (“O&M”) manuals for full scope of the Project
- Provide comprehensive training on all systems to U of T staff
- Meet the requirements of the Tri-Campus Energy Modelling & Utility Performance Standard for all building retrofits as established by the Project Charters (see Appendix D for sample project charters)
- Comply with all applicable U of T standards including, but not limited to, Facilities & Services design, performance standards, and Environmental Health & Safety standards
- Ensure continuity of critical operations and research in laboratory facilities
- Address provisions for future expansion if applicable
- Modernization and Integration of building the Building Automation System (“BAS”) into U of T’s Centralized Management and Reporting System (“EMRS”) portal

6.2 U of T Design Standards

All designs must be compliant with all U of T design standards unless exemptions are approved by the Project Steering Committee.

The latest U of T Design Standards are located here:

<https://www.fs.utoronto.ca/projects/design-standards-and-project-forms/>

<https://ehs.utoronto.ca/resources/standards/>

These shall include but are not limited to:



- Mechanical Design Standard
- Electrical Standards
- Building Commissioning Design Standard
- Building Automation System Design Standard
- Fume Hoods & Fume Hood Exhausts Standard
- Laboratory Design Standard and Guidelines



7.0 FINANCIAL ANALYSIS

Omitted.



APPENDIX A – AHU CONTROLS DIAGRAMS SNAPSHOTS

UofT UNIVERSITY OF TORONTO - 500 UNIVERSITY

82.63 deg F OAir Temperature

PENTHOUSE SYSTEMS

- GLYCOL HEATING PLANT - PENTHOUSE
- REHEAT COIL HYDRONIC - PENTHOUSE
- CHILLED WATER SYSTEM - PENTHOUSE

AIR SYSTEMS

- AHU-1
- AHU INTERIOR
- AHU-1 PERIMETER
- EXHAUST FANS
- AC-1

FLOOR SYSTEMS

- 10TH FLOOR
- 9TH FLOOR
- 8TH FLOOR
- 7TH FLOOR
- 5TH FLOOR
- 4TH FLOOR
- 3RD FLOOR
- 2ND FLOOR
- 1ST FLOOR
- BASEMENT FLOOR

BASEMENT SYSTEMS

- HEATING PLANT - BASEMENT
- INDUCTION WTR SYSTEM - BASEMENT
- CHILLED WATER SYSTEM - BASEMENT
- BACKFLOW PREVENTER - BASEMENT

SUMMER/WINTER MODE

Winter

Dont touch this button unless you are certain you know what you are doing.

It will switch the building between its two modes of operation.

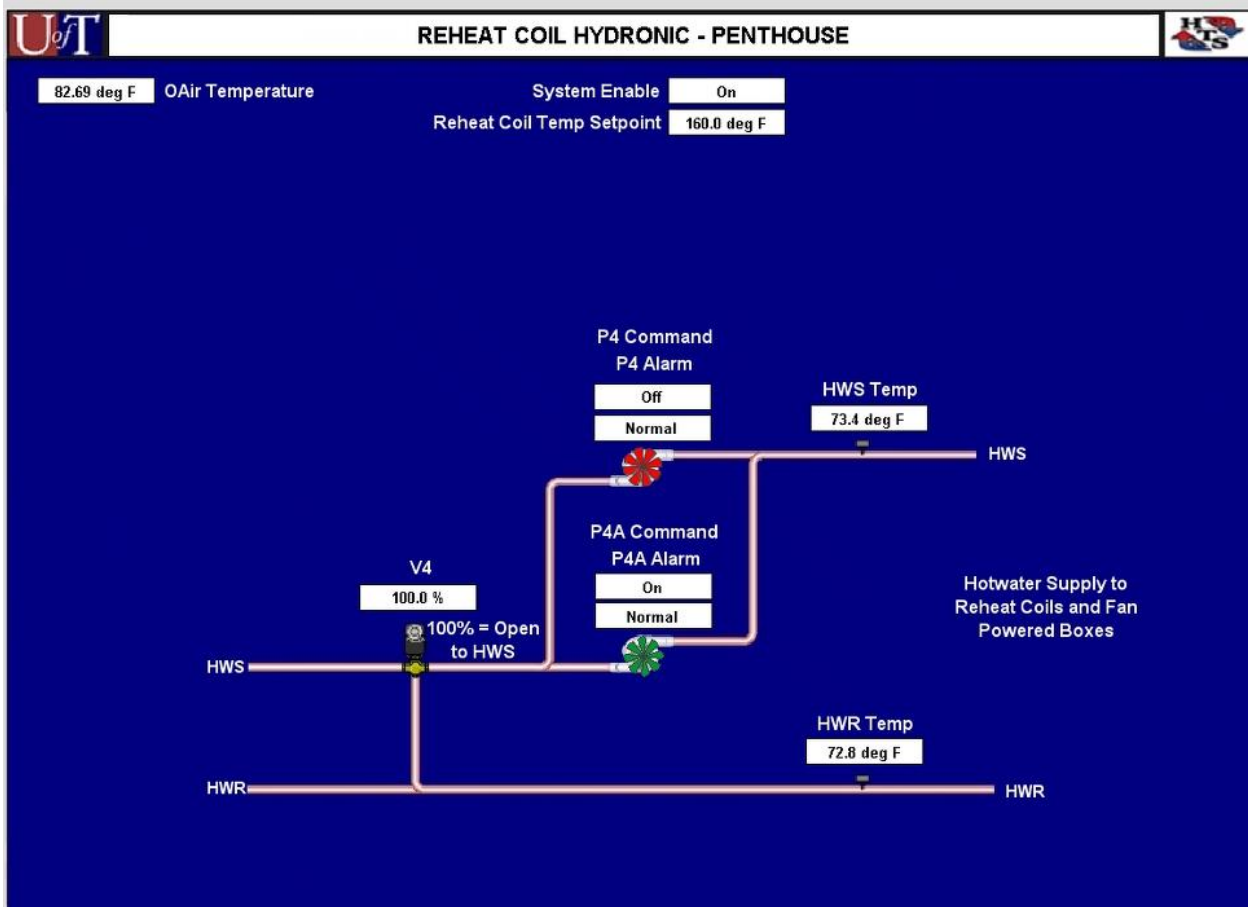

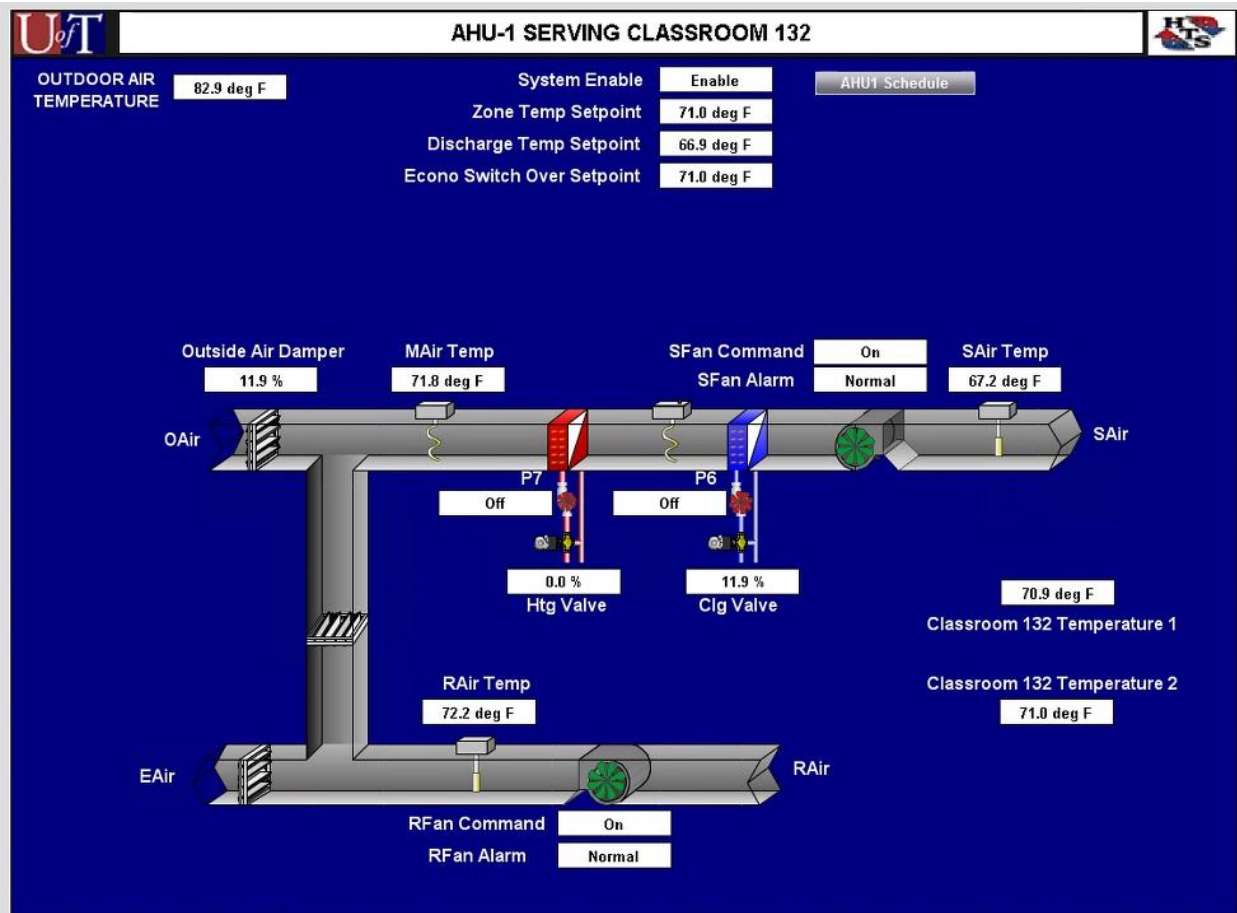

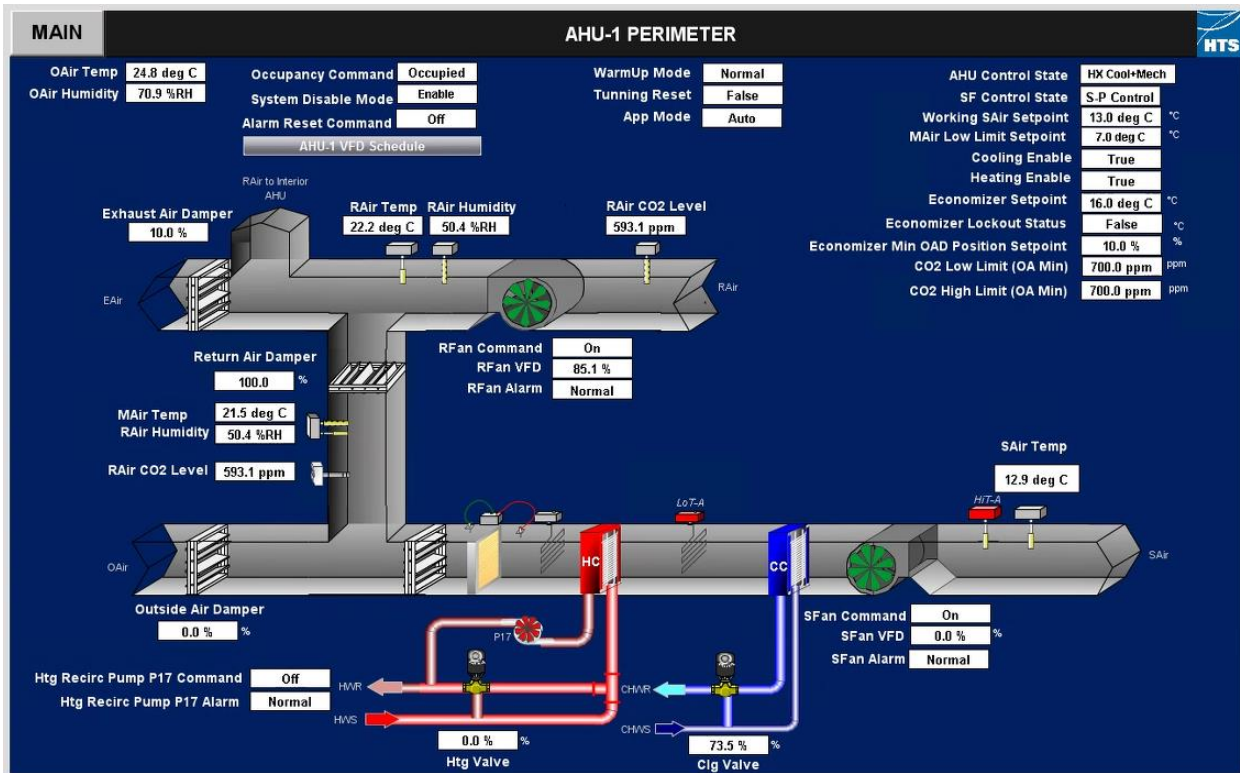

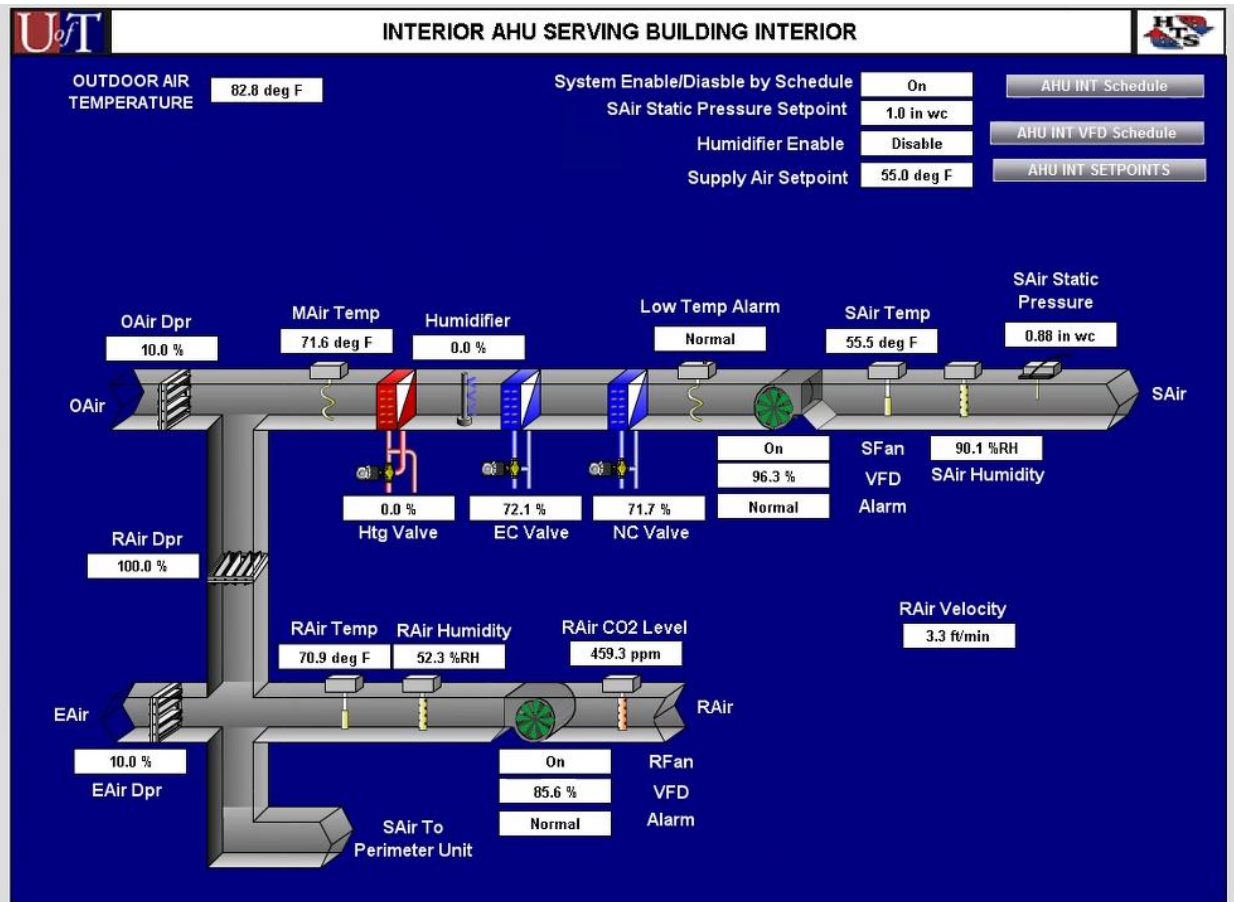



Name: Perimeter_AHU.1
Status: Normal
Date: 2/18/2023 12:23:46 PM
Value: Online
Priority: 108

Description: JCI - SNC16120 ---AHU1 (bldg152)
Alarm Message Text: < Returned to Normal Status >

Actions: Ack, Snooze, Discard, Silence All, Pending Acks: 720, View Item

VAV 4-1-45
Normal

Occupancy: 3.0 (1=Unoccupied, 2=Standby, 3=Occupied)
Common Setpoint: 72.0 deg F

Fan Command: On

From AHU: 29.9 % open
Damper Position: 29.9 % open

Reheat Valve: 100.0 %

SAir

Supply Flow: 84.2 cfm
Supply Flow SP: 89.0 cfm

Zone Temp: 65.8 deg F
W/C Adj: 0.9 deg F

Navigation: Energy, Programming, Schedules, Graphics, Calendars, BACnet, Chiller Study, FC-B, BFP-Rehabilitation Sci, UofT500U-HM03, BACnet Protocol Eng, Eth IP DataLink, Energy, Programming, Schedule, Field Bus 1, Graphic Folder, UofT500U-MA05, BACnet Protocol Eng, Eth IP DataLink, Energy, Programming, Schedule, Field Bus 1, BACnet IP 1, Graphic Folder



APPENDIX B – EXISTING CONDITIONS AND PROPOSED ECM MEASURES SCHEMATIC

Existing Conditions Schematic:

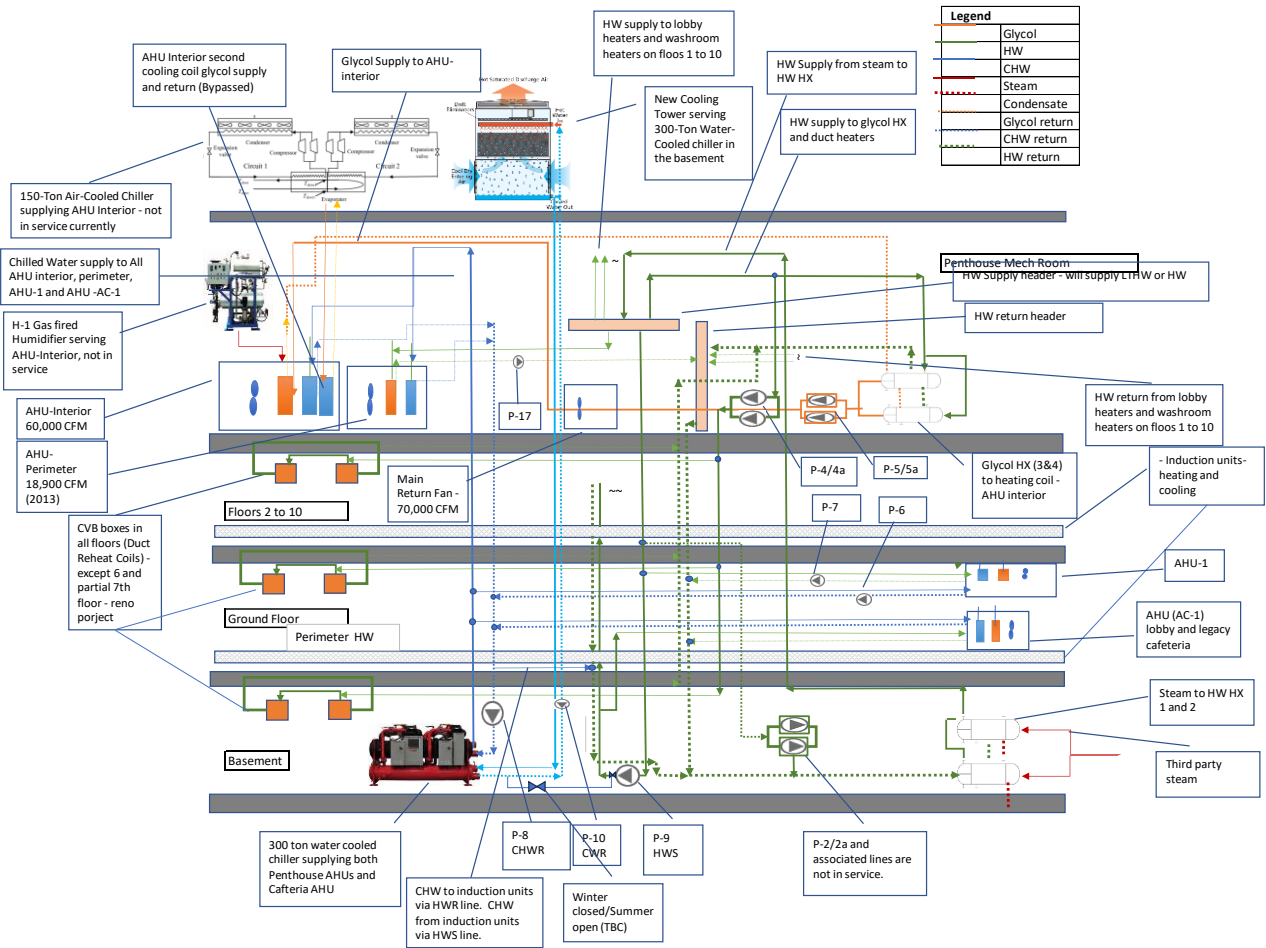

Proposed ECMs Schematic:

