

**FOR ENDORSEMENT
AND FORWARDING**

PUBLIC

CLOSED SESSION

TO: Executive Committee

SPONSOR: Professor Scott Mabury, Vice President, Operations and Real Estate Partnerships

CONTACT INFO: 416-978-2031, scott.mabury@utoronto.ca

PRESENTER: See above.

CONTACT INFO:

DATE: May 2, 2023 for May 9, 2023

AGENDA ITEM: 4 (e)

ITEM IDENTIFICATION:

Capital Project: *University of Toronto Facilities & Services Project Concept Report for the Climate Positive LEAP – Project Scope and Sources of Funding*

JURISDICTIONAL INFORMATION:

Pursuant to section 4.2.3. of the Planning and Budget Committee’s Terms of Reference, “...the Committee considers reports of project planning committees and recommends to the Academic Board approval in principle of projects (i.e. space plan, site, overall cost and sources of funds) with a capital cost as specified in the *Policy on Capital Planning and Capital Projects*.”

Pursuant to section 5.1 of the Academic Board’s Terms of Reference, the Board considers reports of project planning committees (i.e. space plan, site, overall cost and sources of funds) with a capital cost as specified in the *Policy on Capital Planning and Capital Projects*.

The *Policy on Capital Planning and Capital Projects* provides that capital projects with costs in excess of \$50 million (Approval Level 3) on the St. George campus, will first be considered by the Planning & Budget Committee, which shall recommend approval to Academic Board. Following consideration and by the Academic Board and approval for execution by the Business Board, such proposals are then brought forward to the Executive Committee for endorsement, and then forwarded to the Governing Council for approval. [Section 3(b)(ii)(1)(b) and (d)] The Policy further states that "any financing will be approved by the Business Board". [Section 3(c)].

GOVERNANCE PATH:

A. Total Project Cost, and Sources of Funding:

1. Planning and Budget [for recommendation] (April 12, 2023)
2. Business Board [for financing approval] (April 26, 2023)
3. Academic Board [for recommendation] (April 27, 2023)
4. **Executive Committee [for endorsement and forwarding] (May 9, 2023)**
5. Governing Council [for approval] (May 18, 2023)

B. Execution of the Project:

1. Business Board [for approval] (April 26, 2023)

PREVIOUS ACTION TAKEN:

On April 12, 2022, CaPS Executive approved related consultant fees.

On April 26, 2022 Business Board authorized the university to negotiate a conditional financing agreement with the Canadian Infrastructure Bank and a debt arrangement with a third-party lender.

HIGHLIGHTS:

The University of Toronto is committed to becoming climate positive; in order to achieve this goal, decisive, forward-thinking and impactful action must be taken today.

On the University's journey to becoming climate positive, Facilities and Services is proposing a bold initiative: Climate Positive LEAP (Low Emissions Accelerator Project). As proposed, Project LEAP will eliminate more than 50% of the campus' current scope 1 (on-site direct emissions such as natural gas combustion) and scope 2 (off-site indirect emissions, such as purchased electricity) carbon emissions (total 1990 baseline emissions of 90,796 metric tons per year).

Project LEAP goals:

- Eliminate 48,300 metric tons of CO₂ annually, representing 55% of our 2021 Scope 1 and 2 emissions (53.2% in reference to our 1990 baseline year)
- Reduce at least 40% energy use in some of our most energy and carbon intensive buildings
- Add energy system resiliency at both the building and district scale
- Address \$30M of deferred maintenance liability in the district energy infrastructure
- Deliver the project in a financially sustainable manner, relying on carbon tax cost avoidance to fund capital investments
- Accelerate climate positive progress by advancing planned projects from 2035 to 2025 and thereby prevent an additional 436,000 metric tons of emissions

This project is fully aligned with the goals of the Climate Positive Strategy, while also significantly

mitigating deferred maintenance liabilities through a financially sustainable solution. Further to this, Project LEAP allows the St George campus to surpass carbon reduction targets set out by all levels of government as well as the UN IPCC targets (commonly referred to as the science-based targets)

PROJECT LEAP – TARGET COMPARISON

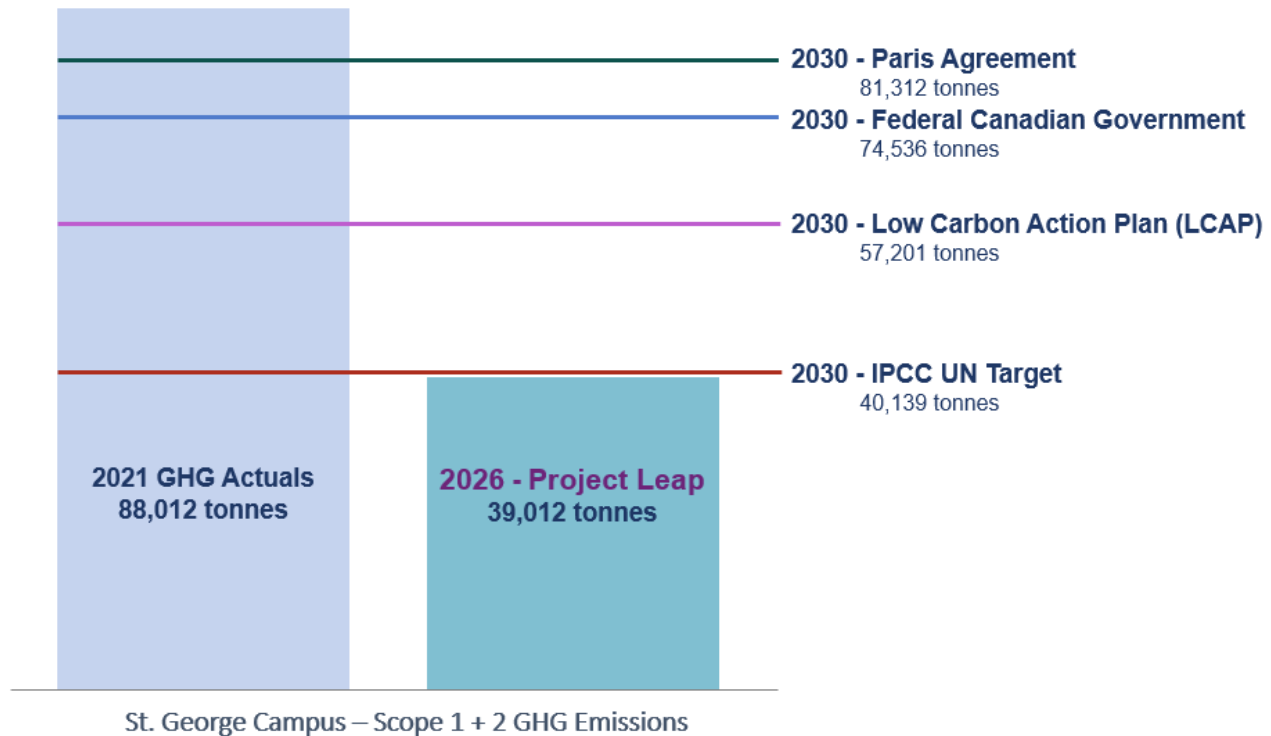

Project LEAP scope:

1. Modernization of the central steam plant and district energy system:
 - Replacement of one of the aged boilers in the central steam plant, installed in 1960, with a new electric boiler.
 - Integration of energy storage and demand response capability into the district energy network to enhance resiliency and reliability while reducing emissions and energy cost.
2. Deep energy retrofits at CCBR and Leslie Dan Pharmacy:
 - Deep retro-commissioning and retrofit of each building including building optimization.
 - Integration of energy storage for load shifting and demand response along with heat recovery.
3. Landmark geo-exchange integration
 - Accelerate the planned mechanical, electrical and piping distribution fit out to fully utilize installed geo-exchange borehole capacity.
 - Optimize the operation of the geo-exchange field to drive greater savings and resiliency and expand the distribution.
 - Install industrial heat pumps which will enable greater lab exhaust heat recovery.

Project LEAP will be executed via a performance-based design-build contract. This contracting methodology allows for significant risk transfer to the private sector while encouraging design innovation. Through this approach, the performance of the project will be guaranteed by the private sector partner. Although this represents the first project at U of T that will be executed using this model, this form of contracting has been used in public sector organizations in Ontario successfully for decades.

Schedule

The overall proposed project schedule is phased as follows:

- | | |
|---|------------------------|
| • CaPS Exec: Request for Consultant Fees | April 12, 2022 |
| • Issue of RFSQ for Private Partners | April 13, 2022 |
| • Business Board Review of Financing Strategy | April 26, 2022 |
| • RFSQ Shortlist Announcement | June 2022 |
| • Issue of RFP to Short List | July 2022 |
| • Detailed Study | January - May 2023 |
| • Cycle 5 Governing Council Full Project Approval | May 2023 |
| • Financial Close, Mobilization & Construction | July 2023 - April 2026 |
| • Anticipated Commissioning Period | May 2026 – April 2027 |
| • Anticipated Guarantee Period | May 2027 – April 2053 |

This schedule assumes all municipal approvals can be achieved within the timelines.

RESOURCE IMPLICATIONS:

Discussion of overall costs and sources of funds can be found in the in-camera document for this project.

RECOMMENDATION:

Be It Resolved

THAT the following recommendation be endorsed and forwarded to the Governing Council.

THAT the project scope of Project LEAP, as identified in the *Concept Report and Technical Submission*, dated March 31, 2023, be approved in principle; and,

THAT the project be approved in principle to be funded through: UTSG Utilities Operating Funds, Federal Grants, and Debt Financing.

DOCUMENTATION PROVIDED:

- *Project Concept Report* dated April 8, 2022.
- Technical Submission, *Project LEAP – Detailed Study Phase*, March 31, 2023

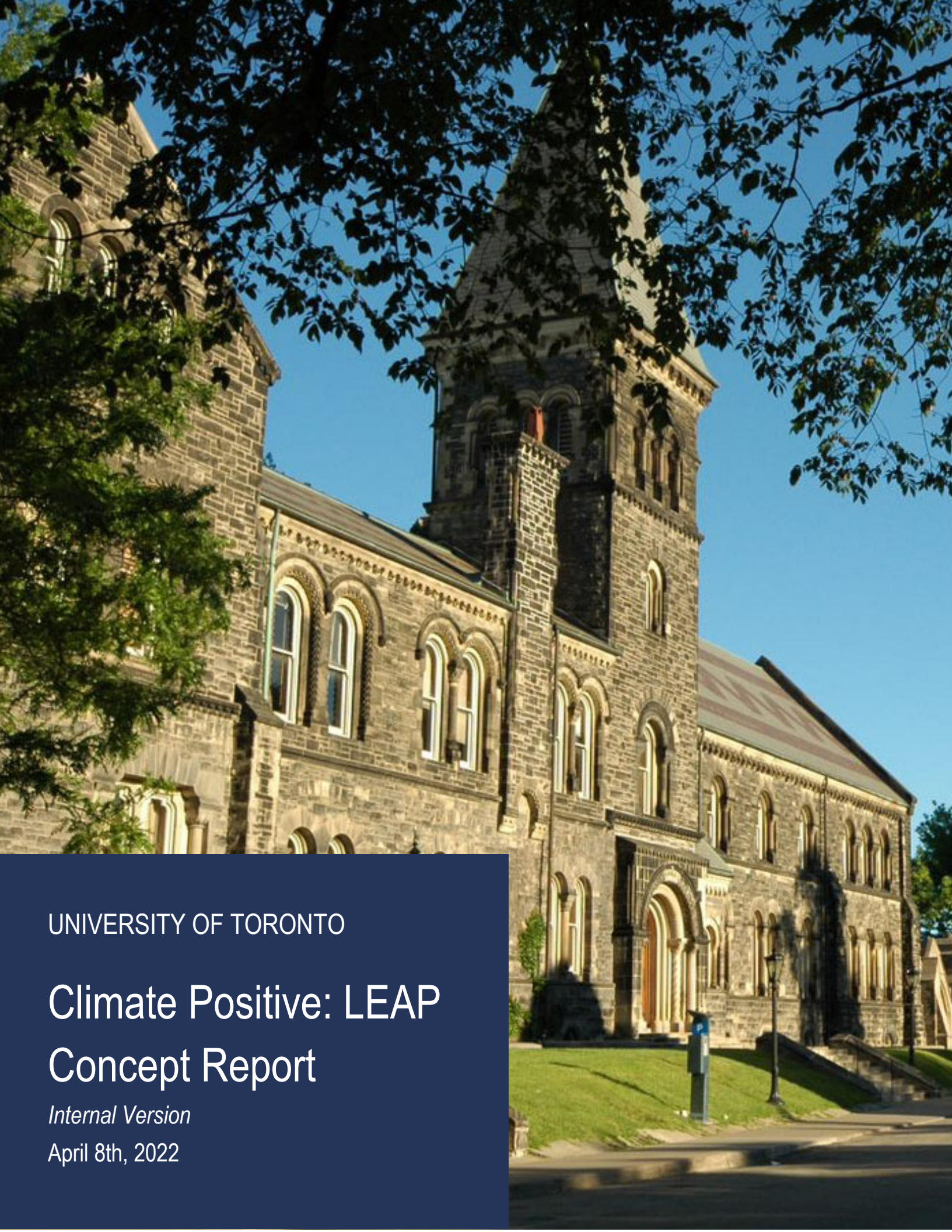

UNIVERSITY OF TORONTO

Climate Positive: LEAP Concept Report

Internal Version

April 8th, 2022



Table of Contents

- 1.0 Executive Summary 5
 - 1.1 Overview 5
 - 1.2 Global Adjustment..... 7
 - 1.3 Energy Conservations Measures (ECMs)..... 8
 - 1.4 Low Carbon Action Plan..... 11
- 2.0 Mandatory Requirements 12
 - 2.1 Outcomes / Performance Metrics..... 12
 - 2.2 U of T Design Standards..... 12
 - 2.3 Infrastructure Renewal 13
- 3.0 Financial Analysis 15
- 4.0 Utility Baseline & Savings Summary 17
 - 4.1 Base Year Rates 17
 - 4.2 Base Year Use and Savings Summary..... 18
- 5.0 Technical Plan..... 20
 - 5.1 Overview 20
 - 5.1.1 Assumptions..... 20
 - 5.1.2 Operational Cost 21
 - 5.1.3 Summary ECMs 22
 - 5.2 Central Heating Plant (CP)..... 25
 - 5.2.1 Existing Conditions..... 25
 - 5.2.2 Energy Conservation Measures (ECMs) 26
 - 5.3 Earth Sciences (ES)..... 42
 - 5.3.1 Existing Conditions..... 42
 - 5.3.2 Energy Conservation Measures (ECMs) 53
 - 5.4 CCBR (DC)..... 65
 - 5.4.1 Existing Conditions..... 65
 - 5.4.2 Energy Conservation Measures (ECMs) 67
 - 5.5 McCaul (MC) 79
 - 5.5.1 Existing Conditions..... 79
 - 5.5.2 Energy Conservation Measures (ECMs) 84
 - 5.6 Leslie Dan Pharmacy (PB)..... 99
 - 5.6.1 Existing Conditions..... 99



5.6.2	Energy Conservation Measures (ECMs)	100
5.7	Campus Wide.....	108
5.7.1	BCIT (BA) Energy Conservation Measures (ECMs).....	108
5.7.2	Convocation Hall (CH)	110
5.7.3	Medical Sciences Building (MS).....	111
5.7.4	Northwest Chiller Plant (NW)	114
5.7.5	Varsity (VA)	117



ABBREVIATIONS

AHRI	Air Conditioning, Heating and Refrigeration Institute
AHU	Air Handling Unit
ASHRAE	American Society of Heating, Refrigerating and Air-Conditioning Engineers
ASME	American Society of Mechanical Engineers
ATS	Automatic Transfer Switch
BAS	Building Automation System
BAU	Business as Usual
BCIT	Bahen Centre of Information Technology
BESS	Battery Energy Storage System
BOP	Balance of Plant
CCBR	Terrence Donnelly Centre for Cellular & Biomolecular Research
CED	Central Electrical Distribution
CFM	Cubic Feet per Minute
CHW	Chilled Water
CMMS	Computer Maintenance Management Systems
CMRS	Central Management and Reporting System
COP	Coefficient of performance
Cogen	Cogeneration Plant
CSP	Central Steam Plant
CSP	Central Steam Plant
CW	Condenser Water
DHW	Domestic Hot Water
EMRS	Energy Management and Reporting System
GA	Global Adjustment
GSHP	Ground Source Heat Pump
GTG	Gas Turbine Generator (Co Gen)
GPM	US Gallons per Minute
HTHW	High Temperature Hot Water
lbs/hr	Pound per Hour (Steam Flow Rate)
ISS	Ice Storage System



IESO	Independent Electricity System Operator
LDC	Local Distribution Company
LTHW	Low Temperature Hot Water
MSB	Medical Sciences Building
PPH	Pounds Per Hour (Steam Flow Rate)
OSHA	Occupational Safety and Health Administration
OWS	Operator Workstation
TH	Toronto Hydro
THESL	Toronto Hydro Electric System Limited
UMP	Site Utility Master Plan
UPS	Universal Power Supply
VFD	Variable Frequency Drive



1.0 EXECUTIVE SUMMARY

1.1 Overview

In recognition that climate change remains one of the most pressing challenges of our time, the University of Toronto St. George campus has committed to becoming climate positive (having net negative emissions) by 2050. Our downtown Toronto campus—the university’s largest and oldest campus—makes up over 80% of the University of Toronto’s operational carbon footprint. Our impact on the institutional footprint and our key role in the community calls for going beyond net-zero carbon emissions to become climate positive by 2050. This means not only reducing the operating emissions under our control, but also mitigating additional carbon emissions to achieve net-negative emissions,

Our first step towards becoming climate positive is to invest in transformational infrastructure renewal as part of our 30-year carbon and energy campus master plan. We are moving towards a renewed, resilient and reliable utility infrastructure that will enable our campus to operate and thrive without disruption and mitigate the impacts of growth on our carbon footprint. Our 2050 plan follows the release of U of T’s tri-campus Low-Carbon Action Plan (2019-24), which focuses on U of T’s 2030 reduction target, and will position the institution to accelerate carbon reductions towards 2050.

While proud of our 2050 plan and commitment, we realize that we need to take decisive action now. As part of the launch of the Climate Positive plan, the University is proposing a bold project, “LEAP,” that would eliminate half of the campus’s current carbon emissions targeted for implementation starting in 2022 with completion in 2025.

The current district energy system supplies the St. George campus with heating, cooling and electrical power. The Central Steam Plant supplies 80% of the campus with heating via steam, high temperature hot or low temperature hot water. Cooling is supplied by three main chilled water plants located at the Medical Sciences Building, the Bahen Centre for Information Technology (BCIT) and the Northwest Chiller Plant. These central cooling plants combine to create 20,000 tons of cooling capacity to meet a peak demand of 11,500 tons.

The Central Steam Plant is highly reliant on fossil fuels, with each of its four steam boilers capable of operating on either natural gas or #2 oil. The 6.5 MW gas turbine cogeneration system also operates on natural gas and produces both electricity and heat for the campus, providing approximately 25% of the total campus electrical demand. Roughly one-third of the University’s total energy is generated via fossil

LEAP Key Objectives

- *Elimination of 45,720 metric tonnes of CO₂, representing 50% of our annual Scope 1 & 2 emissions*
- *No material impact to the Campus’s utility budget*
- *Added energy system resiliency at both the building and district scale*
- *Addresses significant deferred maintenance priority within the district energy network*
- *Max. Project TPC of \$129M*
- *Carbon Tax cost avoidance projected to be \$9M annual once carbon levy reaches \$170/tonne CO₂*



fuels whereas two thirds are derived from purchased electricity. While natural gas costs roughly 9% of the cost of electricity, it is also six times more carbon intensive.

A key element of LEAP integrates demand response technologies such as self-generation using the existing gas turbine, two backpressure steam turbines (one to generate electricity and the other to power a chiller) and peak shifting using ice storage and grid-scale lithium-ion battery packs. These technologies provide the University of Toronto with simple and effective ways to centrally manage coincident peak demand and actively minimize our global adjustment costs.

These strategies also align with and support the University of Toronto's carbon reduction framework's four key principles.

1) Conservation First

Reduce energy use intensity wherever possible in line with the tri-campus performance standards. Implement methods such as steam to hot water conversions. Electrification of heating using heat pumps and aggressive heat recovery

2) Balance Carbon with Cost

Leverage the Industrial Conservation Initiative as a Class A customer to reduce global adjustment costs (electricity tariffs), bringing the commodity cost for both natural gas and electricity on par and enable operation of lower carbon technologies such as electric boilers to reduce natural gas consumption.

3) Reach Beyond Our Own Assets

Installing an electric boiler at our central heating plant affects all buildings connected to our district heating network, including third-party clients allowing us to reach beyond our own assets

4) Fostering Innovative Solutions

LEAP will include several innovative components including small-scale waste-to-fuel (bio digester), carbon capture technology, energy storage, and many demonstrable elements to engage the University of Toronto community and beyond.

The scope of LEAP includes three main categories:

1) District Energy Modernization

- Replacing half of the aged boilers in the Central Steam Plant with electric boilers
- Integrating energy storage and demand response capability into the district energy network to enhance resiliency and reliability while reducing energy cost and emissions

2) Deep energy retrofits at the Terrence Donnelly Centre for Cellular & Biomolecular Research, Leslie Leslie Dan Pharmacy Building, Health Sciences Building, Old Administration, Exam Centre, and Earth Sciences Centre



- Deep retro-commissioning of each including building optimization and steam to hot water conversions in two of our most carbon and energy intensive buildings
- Integrated energy storage for load shifting and demand response along with heat recovery

3) Low Carbon Node

- Eliminating steam use at 155 College St., 263 and 255 McCaul St. All three of these buildings are currently feed by a third-party district steam service, with a contract that expires in November 2027.
- Additional energy conservation measures to address deferred maintenance and reduce building level energy use intensity
- Integrated energy storage for load shifting and demand response along with heat recovery

1.2 Global Adjustment

Global adjustment covers the cost of long-term contracts over the market price, building new electricity infrastructure in the province, as well as delivering Ontario's conservation programs – ensuring that enough electricity supply will be available over the long term.

Customers who participate in the Industrial Conservation Initiative (ICI), pay Global Adjustment (GA) based on their percentage contribution to the top five hours of energy use in Ontario over a 12-month base period (May 1 to April 30). Customers participating in this initiative are referred to as Class A. Class A customers are assessed their portion of GA costs based on the percentage that their consumption contributes to the top five system coincident peaks during a predetermined base period, referred to as their Peak Demand Factor.

For example, if a Class A customer is assessed to be responsible for one per cent of Ontario's coincident peak demand for the five highest hours of a set base period, they will be charged for one per cent of total GA costs through the next adjustment, or billing period.

Class A customers can reduce their GA costs based on their ability to anticipate the top five peak hours for the current base period and reduce their consumption accordingly.

At the end of the 12-month base period (May 1 to April 30), the top five adjusted Allocated Quantity of Energy Withdrawn (AQEW) peak hours will be used to determine the peaks (coincident peaks) to calculate GA allocation for the next 12-month billing period (July 1 to June 30).

Ontario electricity rates can be simply divided into three categories:

- 1) *Energy consumption (kWh)*, the volume of electricity use in kilowatt hours
- 2) *Peak power demand (kW)*, the capacity required in kilowatts
- 3) *Global adjustment (GA)*, an electricity infrastructure recovery charge



The difference between each being how GA fees are charged to the customer. GA charges represent roughly 70% of the overall electrical bill. Under the current Industrial Conservation Initiative (ICI), customers with an average peak demand exceeding 1,000 kW can opt in as a Class A customer if they so choose.

As a district energy and micro-grid operator, becoming a Class A customer represents an opportunity for the University of Toronto to centrally manage coincident peak demand and actively manage our GA costs.

Demand response strategies aimed at reducing the coincident peak demand can effectively level the equivalent cost of natural gas versus electricity.

The more accurately that a Class A customer can predict the top five hours of peak demand and shift their demand accordingly, the more they will be able to take advantage of this initiative. The IESO publishes tools and information to help identify whether the forecasted peak demand for the next 24 hours could be a top 10 Ontario demand peak during the current base period.

Similarly, there are several service providers who monitor current demand and apply algorithms to accurately predict when a peak day will occur. Depending on the service provider, these predictions can be accurate to within two to three hours of the peak event. This tight accuracy allows for very aggressive measures to be implemented over a short period with the intention of minimizing the impact on the building occupants and processes.

1.3 Energy Conservations Measures (ECMs)

The University of Toronto Energy Management team has conducted several building audits to identify 51 Energy Conservation Measures, which can be implemented to reduce energy use intensity and carbon emissions in CCBR, Leslie Dan Pharmacy, Health Sciences Building, Exam Center, Old Administration Building and Earth Sciences.

The following Table 1 details the specific measures for each location.



Table 1: Measure Summary Table

Location	Energy Conservation Measure	Outcome
Central Plant & CED District	Ice Storage Systems Add Electric Boilers CERT Carbon Emissions into Feedstock Gas Turbine Inlet Air Cooling Back Pressure Steam Turbine Campus Wide Demand Management SEab Biodigester Operate Gas Turbine for Demand Response Operate Steam Chiller for GA 5CP Battery Energy Storage Systems	7MW of Ice Storage for Demand Response 40,980 tCO2e GHG Reduction Support U of T Research 36MW of Total Demand Response 0.5MW of Demand Response 6MW of Potential Demand Response Campus Organic Waste to Fuel Measure 6.5MW of Demand Response with Inlet Cooling 2MW of Demand Response 10MW of Battery Storage for Demand Response
CCBR & LD Pharmacy	Lighting Upgrades Low Temp Hot Water Conversion General VAV/DCV & Pump VFDs Heat Recovery Chillers & Exhaust Air Heat Recovery Upgrade BAS and Commission Battery Energy Storage System Adiabatic Humidification	43% in Total Reduction in EUI 3,400 tCO2e GHG Reduction Optimise Building Efficiency 900-Tons of Heat Pump Heat Recovery Improve Building Comfort 1.6MW of Battery Storage Reduce Steam Use
Earth Sciences	Upgrade Lighting to LED Heat Recovery Chiller Upgrade BAS, + DCV, and Recommission Low Temp Hot Water Conversion Solar Thermal Water Solar PV	21% Total Reduction in EUI 150-Ton Heat Pump Improve building comfort 450 tCO2e GHG Reduction 18 Flat Plate Solar Collectors 55kW of Rooftop PV
McCaul Cluster Health Sciences Exam Centre Old Admin	Upgrade Lighting to LED in EX & OA McCaul Electrification with GSHP Battery Energy Storage System Combine Elect Service and Upgrade Upgrade BAS, + DCV and Recommission Install Rooftop PV	36% Total Reduction in EUI 1,000 tCO2e GHG Reduction 1MW of Battery Storage Upgrade to Lower Cost Elect Class A Billing Improve Building Comfort 125kW of Rooftop PV



The following table summarizes the Demand & Ice Capacity and that are to be utilized for GA Peak Mitigation.

Table 2: Summary Demand Capacity Table

ECM ID	Description	CED	Installed Capacity (kW)	Utilised Capacity (kW)
BA-ECM-01	Ice Storage System (3 hrs)	No	1,200	1,200
CP-ECM-01	Add Electric Boilers	Yes	17,244	17,244
CP-ECM-03	Gas Turbine Inlet Air Cooling	Yes	1,100	1,100
CP-ECM-04	Back Pressure Steam Turbine	Yes	500	500
CP-ECM-05	Campus Wide Demand Management (6MW)	No	6,000	456
CP-ECM-06	Battery Energy Storage System (3 hrs)	Yes	6,000	6,000
CP-ECM-08	Turn Off GTG and Operate for DR	Yes	5,471	5,471
DC-ECM-07	Battery Energy Storage System (3 hrs)	No	1,100	968
MC-ECM-03	Battery Energy Storage System (3 hrs)	No	1,000	1,000
MS-ECM-01	Ice Storage System (3 hrs)	Yes	3,760	3,760
MS-ECM-02	Operate Steam Chiller for GA 5CP	Yes	2,240	2,240
NW-ECM-01	Ice Storage System (3 hrs)	Yes	2,000	2,000
NW-ECM-02	Battery Energy Storage System (3 hrs)	Yes	2,000	1,600
PB-ECM-05	Battery Energy Storage System (3 hrs)	No	500	242
VA-ECM-01	Battery Energy Storage System (3 hrs)	Yes	2,000	1,600
Totals			52,115	45,381

Table 3: Ice Storage Tank Quantities

Item	MS	BA	NW	Units/Notes
Peak Electrical Cooling Load	4,700	1,500	2,500	Tons
Number of Hours to Load Shift	3	3	3	Hours
Diversity	0.9	0.9	0.9	
Load Shift (Ton-Hrs)	12,690	4,050	6,750	Ton-Hours
Number of 1500C Modules	40	13	21	
Number of Hours to Load Shift	2	2	2	
Load Shift (Ton-Hrs)	8,460	2,700	4,500	Ton-Hours
Number of 1500C Modules	26	8	14	



Turner & Townsend, and Hooker and Associates have been retained to provide preliminary class-D costing for all the above measures. Based on this costing exercise we have a draft Total Project Cost (TPC) of \$129 million, excluding financing costs, broken by building in Table 4.

Table 4: Building Summary

Building/Area	Electric Savings			Thermal Savings			Saving Totals		Cost Est
	kWh	tCO ₂ e	\$	MMBtu	tCO ₂ e	\$	tCO ₂ e	\$	
CED/CSD/BCIT	-213,313,202	-6,399	-\$4,241,035	901,996	47,273	\$2,878,804	40,874	-\$1,362,292	\$58,790,937
CCBR/LD	-3,078,344	-92	\$369,607	67,312	3,528	\$555,202	3,435	\$924,810	\$25,643,905
McCaul	-1,166,213	-35	\$158,653	13,370	1,001	\$290,119	962	\$448,772	\$14,715,963
Earth Sciences	921,517	29	\$199,812	7,995	419	\$65,946	447	\$262,535	\$7,883,498
ECM Cost Total									\$107,025,000
Plus TPC									\$21,848,000
TOTAL	-216,636,000	-6,499	-\$3,515,200	990,670	52,221	\$3,790,070	45,718	\$274,800	\$128,873,000

1.4 Low Carbon Action Plan

The addition of LEAP to the U of T Low Carbon Action Plan (LCAP) will provide for an additional 24,000 tCO₂e reduction or avoidance at a tri-campus level by end of calendar 2024, bringing the total tri-campus reduction or avoidance from 2019 to 2024 to 68,500 tCO₂e from a forecasted scope 1&2 baseline of 130,000 tCO₂e per year in 2024. The result is not only a 50% reduction in the GHG emissions for the St. George campus from LEAP but also an overall reduction of 50% for the University of Toronto Tri-Campus GHG emissions when combined with the planned LCAP projects.

This initiative plays a key role in the U of T meeting or exceeding its 2030 commitments to mitigate the impacts of climate change thru a 37% GHG reduction relative to a 1990 baseline.



2.0 MANDATORY REQUIREMENTS

The following is a list of mandatory requirements for LEAP.

2.1 Outcomes / Performance Metrics

The following is a list of performance-based metrics:

- Compliance with the University of Toronto Tri-Campus Energy Modelling and Utility Performance Standard. Achieve the minimum performance metrics outlined in the project charter for each of the buildings within the scope of the project
- Alignment with U of T's Master Plan
- Elimination of at least 46,000 tCO₂e, representing 50% of our annual Scope 1 & 2 emissions this must include any increase GHG values
- No increase to the Campus's utilities, budget must be the same or reduced using the baseline and rates provided
- Maximize NPV using the U of T provided LCCA template
- Limit the annual starts of the existing cogeneration unit to < 30/Yr.
- Include options for extended equipment warranties.

2.2 U of T Design Standards

All designs must be compliant with all U of T design standards unless exemptions are approved by the Project Steering Committee.

The latest U of T Design Standards are located here:

<https://www.fs.utoronto.ca/projects/design-standards-and-project-forms/>

<https://ehs.utoronto.ca/resources/standards/>

These shall include but are not limited to

- Design Standard Part 1
- Design Standard Part 2
- Commissioning Standard
- Building Automation Standard
- Fume Hoods & Fume Hood Exhausts Standard
- Laboratory Design Standard
- Indoor Air Quality Standard



2.3 Infrastructure Renewal

The following is the mandatory list of ECMs that addresses in infrastructure renewal.

Central Plant and Campus Wide ECMs

- Removal of gas fired steam Boiler #4 and replacement with required capacity to maintain equivalent resiliency (N+1) for a maximum campus demand of 280,000 pph
- Make room and supply services for CERT installation
- Install Biodigester (SEab or equivalent) capable of processing the daily volumes of organics available from the U of T, 500-3000kg/day.
- Remove the single point of failure on the main steam header
- Remove the MSB chiller plant chillers #1, 6, &7 from the deferred maintenance liability while ensuring cooling capacity and plant resiliency of N+1
- Remove the NW chiller plant chiller #2 from the deferred maintenance liability while ensuring cooling capacity and plant resiliency of N+1
- Remove the BCIT chiller plant chiller #1 from the deferred maintenance liability while ensuring cooling capacity and plant resiliency of N+1
- Addressing lack of centralized compressed air redundancy in MSB

Earth Sciences (EA)

- Convert building to LTHW (135°F)
- Building Automation Upgrade
- Include renewable ECMs (Solar PV, Solar Thermal, Geo, etc.)
- Replacement of 1 chiller with ideally Heat Recovery Chiller
- Upgrade greenhouse lighting to LED, fixtures subject to approval by Project steering committee
- Heat recovery (active preferred)

CCBR (DC)

- Convert building to LTHW (135°F)
- Include renewable ECMs (Solar PV, Solar Thermal, Geo, etc.)
- Heat recovery (active preferred)
- Upgrade the BAS



McCaul Combined (HA, EX, OA)

- Electrify and detach from Enwave district steam for all buildings before November 2027 and when current Enwave contract expires.
- Upgrade front end of the existing BAS' in OA, HA,
- Include renewable ECMs (Solar PV, Solar Thermal, Geo, etc.)
- Convert Gas DHW to electric
- Removal of the existing 500T chiller and replacement with required cooling capacity
- Include investigation of HVAC comfort issues for OA (air distribution)
- Heat recovery (active preferred)

Leslie Dan Pharmacy (LD)

- Convert building to receive Nodal LTHW (135°F)
- Include renewable ECMs (Solar PV, Solar Thermal, Geo, etc.)
- Upgrade front end of the existing BAS system
- Heat recovery (active preferred)



3.0 FINANCIAL ANALYSIS

The following is the preliminary Proforma for the project.

Table 5: Proforma

LEAP - Input Page														
Return Analysis														
15 Year Unleveraged IRR	5.49%													
15 Year Leveraged IRR	11.91%													
Cost and Capital Assumptions														
Cost Assumptions	Allocation of Costs	Percentage of Total Costs												
TPC Cost	\$129,000,000	100.00%												
Non Shareable Costs	\$0	0.00%												
Total Shareable Costs	\$129,000,000	100.00%												
UofT Percentage Interest	20%	20.00%												
Remaining Interest	\$103,200,000	80.00%												
Total Partner Amount	30%	24.00%												
CIB Percentage Interest	70%	56.00%												
Partner Capital Assumptions														
Total Partner Amount	\$30,960,000	24.00%												
Percentage of Equity	\$0.00	0.00%												
Percentage of Debt	\$30,960,000.00	24.00%												
Equity Assumptions														
Partner Equity	0.00%	\$0.00												
Preferred Interest Rate	12.00%													
Equity Return	\$0													
Debt Assumptions														
Partner Debt	24.00%	\$30,960,000.00												
Interest Rate	4.00%													
Loan Period	15 Years													
Amortization Period	25 Years													
Payments Per Year	12													
Compounding Frequency	2													
Annual P+I Payment	\$1,954,270													
CIB Financing Assumptions														
CIB Debt	\$72,240,000	56.00%												
Interest Rate	1.00%													
Loan Period	15 Years													
Amortization Period	25 Years													
Payments Per Year	12													
Compounding Frequency	2													
Annual P+I Payment	\$3,266,217													
UofT Financing Assumptions														
UofT Funds	\$25,800,000	20.00%												
Percentage Loaned	0.00%													
UofT's Financing Amount	\$0													
Interest Rate	1.00%													
Loan Period	15 Years													
Amortization Period	25 Years													
Payments Per Year	12													
Compounding Frequency	2													
Annual P+I Payment	\$0													
WACC	1.52%													
Energy Usage and Costs														
Usage	Year 1 2025	Year 2 2026	Year 3 2027	Year 4 2028	Year 5 2029	Year 6 2030	Year 7 2031	Year 8 2032	Year 9 2033	Year 10 2034	Year 11 2035	Year 12 2036	Year 13 2037	Year 14 2038
CO2 Reduction	26,200	52,400	52,400	52,400	52,400	52,400	52,400	52,400	52,400	52,400	52,400	52,400	52,400	52,400
Carbon Tax Rate (\$/tonne)	\$95	\$110	\$125	\$140	\$155	\$170	\$170	\$170	\$170	\$170	\$170	\$170	\$170	\$170
Operating Cost Savings	\$138,808	\$277,600	\$277,600	\$277,600	\$277,600	\$277,600	\$277,600	\$277,600	\$277,600	\$277,600	\$277,600	\$277,600	\$277,600	\$277,600
Analysis Start			Jan-25											
Valuation Metrics			Discount Rate 8.00%											
			Inflation 3.00%											
			Utilities Inflation 0.00%											
			Terminal Discount Rate 5.00%											
Allocation by Year			Year 1	Year 2	Year 3	Total								
Construction Financing			Full Capital Amount	1	2	3	100.00%	Seniority/Priority		Capital Source				
Percentage Allocation by Year			33.00%	33.00%	34.00%	100.00%	3	Partner Equity						
Total Costs			\$42,570,000	\$42,570,000	\$43,860,000	\$129,000,000	4	Partner Debt						
Total by Year			\$42,570,000	\$42,570,000	\$43,860,000	\$129,000,000	2	CIB Debt						
Cumulative Development Cost Total			\$42,570,000	\$85,140,000	\$129,000,000		1	UofT Funds						
Draw Schedule														
1	UofT Funds	\$25,800,000	\$25,800,000	\$0	\$0	\$25,800,000								
2	CIB Debt	\$72,240,000	\$16,770,000	\$42,570,000	\$12,900,000	\$72,240,000								
3	Partner Equity	\$0	\$0	\$0	\$0	\$0								
4	Partner Debt	\$30,960,000	\$0	\$0	\$30,960,000	\$30,960,000								
Total Financing Amount			\$42,570,000	\$42,570,000	\$43,860,000	\$129,000,000								
Cumulative Draw Amounts														
UofT Funds			\$25,800,000	\$25,800,000	\$25,800,000	\$25,800,000	\$77,400,000							
CIB Debt			\$72,240,000	\$16,770,000	\$59,340,000	\$72,240,000	\$148,350,000							
Partner Equity			\$0	\$0	\$0	\$0	\$0							
Partner Debt			\$30,960,000	\$0	\$0	\$30,960,000	\$30,960,000							
Accrued Interest Amounts														
UofT Funds			0.00%	\$0	\$0	\$0	\$0							
CIB Debt			1.00%	\$167,700	\$593,400	\$722,400	\$1,483,500							
Partner Equity			12.00%	\$0	\$0	\$0	\$0							
Partner Debt			4.00%	\$0	\$0	\$1,238,400	\$1,238,400							
Interest Payments			\$167,700	\$593,400	\$1,960,800	\$2,721,900								
Cumulative Interest Payments			\$167,700	\$761,100	\$2,721,900	\$2,721,900								
Standby Fees			\$0	\$0	\$0	\$0								
Total Costs Inc. Interest			\$42,737,700	\$85,901,100	\$131,721,900	\$131,721,900								



Unleveraged Incremental Cash Flows																	Terminal Year
	Initial C	Year 1	Year 2	Year 3	Year 4	Year 5	Year 6	Year 7	Year 8	Year 9	Year 10	Year 11	Year 12	Year 13	Year 14	Year 15	Year 16
		2025	2026	2027	2028	2029	2030	2031	2032	2033	2034	2035	2036	2037	2038	2039	2040
Project Cost	#																
Class A Conversion Costs	#																
Operating Cost Savings		\$138,808	\$277,600	\$277,600	\$277,600	\$277,600	\$277,600	\$277,600	\$277,600	\$277,600	\$277,600	\$277,600	\$277,600	\$277,600	\$277,600	\$277,600	\$277,600
Carbon Tax Savings		\$2,489,000	\$5,764,000	\$6,550,000	\$7,336,000	\$8,122,000	\$8,908,000	\$8,908,000	\$8,908,000	\$8,908,000	\$8,908,000	\$8,908,000	\$8,908,000	\$8,908,000	\$8,908,000	\$8,908,000	\$8,908,000
Terminal Value																	\$116,902,000
Incremental Unleveraged Cash Flows	#	\$2,627,808	\$6,041,600	\$6,827,600	\$7,613,600	\$8,399,600	\$9,185,600	\$9,185,600	\$9,185,600	\$9,185,600	\$9,185,600	\$9,185,600	\$9,185,600	\$9,185,600	\$9,185,600	\$9,185,600	\$126,087,600
Leveraged Incremental Cash Flows																	Terminal Year
	Initial C	Year 1	Year 2	Year 3	Year 4	Year 5	Year 6	Year 7	Year 8	Year 9	Year 10	Year 11	Year 12	Year 13	Year 14	Year 15	Year 16
		2025	2026	2027	2028	2029	2030	2031	2032	2033	2034	2035	2036	2037	2038	2039	2040
Project Cost	#																
Class A Conversion Costs	#																
CIB Financing	#																
Partner Financing	#																
UoFT Financing	#																
CIB Financing P+I		-\$3,266,217	-\$3,266,217	-\$3,266,217	-\$3,266,217	-\$3,266,217	-\$3,266,217	-\$3,266,217	-\$3,266,217	-\$3,266,217	-\$3,266,217	-\$3,266,217	-\$3,266,217	-\$3,266,217	-\$3,266,217	-\$3,266,217	-\$3,266,217
Partner Equity Return		\$0	\$0	\$0	\$0	\$0	\$0	\$0	\$0	\$0	\$0	\$0	\$0	\$0	\$0	\$0	\$0
Partner Debt P+I		-\$1,954,270	-\$1,954,270	-\$1,954,270	-\$1,954,270	-\$1,954,270	-\$1,954,270	-\$1,954,270	-\$1,954,270	-\$1,954,270	-\$1,954,270	-\$1,954,270	-\$1,954,270	-\$1,954,270	-\$1,954,270	-\$1,954,270	-\$1,954,270
UoFT Financing P+I		\$0	\$0	\$0	\$0	\$0	\$0	\$0	\$0	\$0	\$0	\$0	\$0	\$0	\$0	\$0	\$0
CIB Financing Outstanding Balance																	-\$31,073,053
Partner Debt Outstanding Balance																	-\$16,110,194
Partner Equity Amount																	\$0
UoFT Financing Outstanding Balance																	\$0
Operating Cost Savings		\$138,808	\$277,600	\$277,600	\$277,600	\$277,600	\$277,600	\$277,600	\$277,600	\$277,600	\$277,600	\$277,600	\$277,600	\$277,600	\$277,600	\$277,600	\$277,600
Carbon Tax Savings		\$2,489,000	\$5,764,000	\$6,550,000	\$7,336,000	\$8,122,000	\$8,908,000	\$8,908,000	\$8,908,000	\$8,908,000	\$8,908,000	\$8,908,000	\$8,908,000	\$8,908,000	\$8,908,000	\$8,908,000	\$8,908,000
Terminal Value																	\$116,902,000
Incremental Leveraged Cash Flows	#	-\$2,592,679	\$821,113	\$1,607,113	\$2,393,113	\$3,179,113	\$3,965,113	\$3,965,113	\$3,965,113	\$3,965,113	\$3,965,113	\$3,965,113	\$3,965,113	\$3,965,113	\$3,965,113	\$3,965,113	\$73,683,866
DSCR		0.50x	1.16x	1.31x	1.46x	1.61x	1.76x	1.76x	1.76x	1.76x	1.76x	1.76x	1.76x	1.76x	1.76x	1.76x	1.76x



4.0 UTILITY BASELINE & SAVINGS SUMMARY

The first step in reducing building energy consumption at U of T is to accurately summarize building energy use by tracking and analyzing utility consumption and cost. From a Central Plant perspective 2016/2017 was selected as the Base Year and considered to be the most normal before COVID and the GTG operational issues in 2018.

For the buildings we have selected the most current year 2018 prior to COVID as our Base Year. Weather normalization is not completed at this stage but is recommended for the next detailed stage of the process. Base load includes lighting, fans, pumps, elevators, domestic hot water and office equipment (plug load). Weather Sensitive loads include space heating and humidification, space cooling and de-humidification, cooling tower summer water use and additional winter lighting due to shorter daylight hours.

This model's new adjusted baseline is based on an electrical Class A rate structure with the GTG operating. Without any operational demand management Class A vs Class B varies from year to year but remains similar in costs. While there are savings from switching from Class B to Class A with demand management this has not been included at this stage. The model does include a cost to switch from Class B to Class A based on current rates and hourly data included in the model for the CED but not for the other sites. For other sites any switch from Class B to A we would include demand management, so costs remain close to neutral or better for the switch.

Water ECMs are not included at this stage but will be at a later stage.

4.1 Base Year Rates

The modelled savings are based on the following assumptions.

It should be noted:

- Gas rates do not include any carbon tax.
- The electric rates are based on the latest year of data obtained from IESO for HOEP, & Class B and includes Toronto Hydro's distribution charge of \$0.0039/kWh. Demand is comprised of Network charge (\$2.9767 per peak kW), Connection charge (\$2.3743 per peak kW), Distribution Volumetric Rate (\$7.3909 per kVA) and Transformer Ownership credit (\$0.62 per kVA). Rate Riders are small, short lived rate adjustments.
- The GA rates are based on the rates for 2021 to align with Government offloading some GA costs to tax base in 2021. Other rates are based on historical 12/24-month periods. Because first year project savings are not expected until 2025 a full market forecast is continually being updated with modelled cash flows. A full rate sensitivity analysis is also being separately performed. Marginal changes in rates (or sparks spread) can have a significant effect on savings.
- The gas rates only include the current gas cost plus delivery obtained from Jupiter (utility consultant) and does not include any carbon tax.



- Thermal savings are done at the building level on the marginal thermal rate to reduce use of fossil fuel loads first at the plant level.

Table 6: Base Year Rates

ELECTRIC ASSUMPTIONS				THERMAL ASSUMPTIONS			
GA per kW	\$407 \$/kW ^{GA}	HOEP	\$0.0233 \$/kWh	Enwave	74.90 kg/MMBtu	Enwave	\$21.70 \$/MMBtu
Blended CED GA Rate (Miss)	-\$122 \$/kW ^{GA}	Class B	\$0.0834 \$/kWh	GHG	52.41 kg/MMBtu	Blended Gas	\$3.19 \$/MMBtu
Electric GHG 2019 NIR	0.030 kg/kWh	Month Dem	\$12.122 \$/kW ^{Mpk}	Blended	27.51 kg/MMBtu	Electric Rate	\$12.41 \$/MMBtu
Demand Response (DR)	\$50 \$/kW ^{DR}	Blend CED	-\$0.005 \$/kWh			Steam Rate	\$8.25 \$/MMBtu

4.2 Base Year Use and Savings Summary

The following tables summarizes usage and savings for each utility account.

Table 7: Base Year Use and Savings Summary

Account	Fuel			tCO2e	Notes
CSP/CED/BCIT	Electricity				Separate Account
	Base Year	101,817,632	kWh	3,055	GTG On. Class B
	Post Year	315,130,835	kWh	9,454	With Elect Boiler On & GTG Off
	Savings	-213,313,202	kWh	-6,399	
	Natural Gas Rate				CSP Gas Account
	Pre	1,418,622	MMBtu	74,349	Includes GTG, ES, CCBR, LD
	Post	516,627	MMBtu	27,076	Includes GTG Savings
	Savings	901,996	MMBtu	47,273	Excludes ES, CCBR, & LD
	CCBR & LD	Electricity			
Base Year		15,615,308	kWh	468	Class A
Post Year		18,693,652	kWh	561	Class A
Savings		-3,078,344	kWh	-92	Class A
Base Year		2,316	kW ^{GA}		Class A. Update with actuals.
Post Year		1,016	kW ^{GA}		Based on Achieving 3.5/5 of GA Pk + Lights
Savings		1,299	kW ^{GA}		Max is 1600
Base Year		2,316	kW ^{Mpk}		Multiple Rate x 12
Post Year		3,332	kW ^{Mpk}		Multiple Rate x 12
Savings		-1,016	kW ^{Mpk}		Increase due to Electrification.
Max DR		1,200	kW ^{DR}		Revenue Stream @ 100%
Thermal Rate				Fed From CSP	
Base Year		0	MMBtu		Included in CSP
Post Year		0	MMBtu		Not included in CSP
Savings		67,312	MMBtu	3,528	Thermal Rate



Account	Fuel		tCO ₂ e	Notes
McCaul	Electricity			Separate Account
	Base Year	3,630,052 kWh	109	Class B
	Post Year	4,796,265 kWh	144	Electrification. Class A
	Savings	-1,166,213 kWh	-35	Class A
	New GA	751 kW ^{GA}		New Class A Peak
	GA Savings	751 kW ^{GA}		Reduce GA with ECMs
	Total	0 kW ^{GA}		GA Miss
	Base Year	751 kW ^{Mpk}		Multiple Rate x 12
	Post Year	1,231 kW ^{Mpk}		Multiple Rate x 12
	Savings	-481 kW ^{Mpk}		Multiple Rate x 12
	Max DR	751 kW ^{DR}		Revenue Stream @ 100%
	Enwave Rate			Separate Account
	Base Year	13,369 MMBtu	1,001	\$21.70/mmBtu
	Post Year	0 MMBtu	0	\$21.70/mmBtu
	Savings	13,369 MMBtu	1,001	\$21.70/mmBtu
	Nat Gas			Separate Gas Account
	Base Year	134 MMBtu	7	
	Post Year	0 MMBtu	0	
	Savings	134 MMBtu	7	
ES	Electricity			Fed from CED
	Base Year	0 kWh		Included in CED
	Post Year	0 kWh		Not Included in CSP
	Savings	921,517 kWh	28	Reduce from CED
	Base Year	0 kW ^{GA}		
	Post Year	0 kW ^{GA}		
	Savings	245 kW ^{GA}		Not Included in CSP
	Base Year	0 kW ^{Mpk}		
	Post Year	0 kW ^{Mpk}		
	Savings	137 kW ^{Mpk}		Not included in CSP
	Savings	0 kW ^{DR}		
	Thermal Rate			Fed From CSP
	Pre	0 MMBtu		Included in CSP
	Post	0 MMBtu		Not included in CSP
	Savings	7,995 MMBtu	419	Thermal Rate. Not included in CSP



5.0 TECHNICAL PLAN

5.1 Overview

This Concept Report is to be considered a preliminary stage savings analysis that aligns well with ASHRAE Level 1+ Audit +/- 20%/30%. Accuracy of any single measure is crude, but when measures are

"calibrated" to utility data and then many measures added together, the net result should be quite accurate. However, an ASHRAE Level 3 is planned before financial close 2023 with use of a third-party performance-based design build contract. The ECMs selected in this section will NOT be the final ECMs and only intended to provide a feasible business case to warrant progress to ASHRAE Level 2, and if still viable to proceed to an ASHRAE Level 3 for financial close again if still viable. Basically, for a proof of concept.

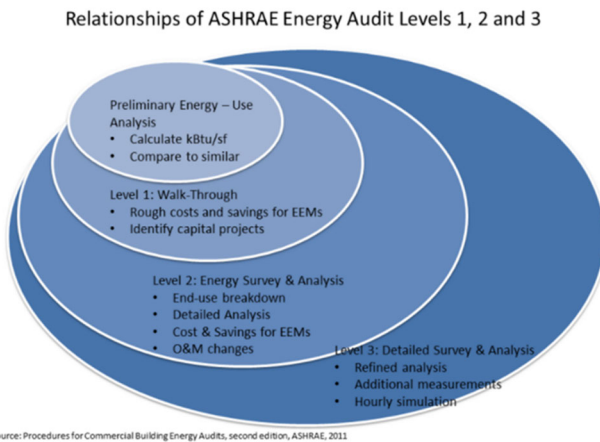

Figure 1: ASHRAE Audit Levels

Additional ECMs not financially included at this stage such ECMs such Lab DCV and active heat recovery have much lower paybacks.

They are not included at this stage for example

and once introduced during the next detailed stage can offer a much-improved business case.

5.1.1 Assumptions

The following assumptions have been assumed.

- This model assumes the Class A billing structure will be around in 2025+. Given that it was originally conceived to save Ontario Industry gives confidence to its continuation alone. In addition, there has been significant investment over long term contracts (10 yrs. +) based on GA peak mitigation - another industry to be affected. However, the Government did effectively reduce the GA by about 20% to the tax base. But as more is electrified and grid constraints occur additional peak demand management programs will occur for other sources of revenue for U of T to participate in.
- U of T has involved Toronto Hydro WRT to this project. The model is based on the following electrical assumptions:
- For the CED, Toronto Hydro providing an increase to 45MVA of continuous load with a back feeder. At the time of writing this report, we're in the process of securing that capacity.
- That Toronto Hydro's Cecil TS and U of T's electrical system can absorb an additional 10MW of short circuit for peak demand mitigation ECMs for the proposed parallel grid operation of demand based ECMs (BESS, Solar PV, etc.). This is in addition to the already installed capacity of equipment such as: GTG, Back Pressure Steam Turbine, Solar PV, etc.



- We have built in thermal storage as a mitigation strategy (operates islanded), and secondly can design ECMs to be islanded as a second mitigation strategy but that has not been included at this stage.
- There are 2 basic modes of failure for coincident peak grid alignment:
 - 1) Prediction Service misses peak or some portion (can be mitigated with multiple prediction services)
 - 2) Even with the correct prediction, operationally peaks are missed due to deficiencies, seasonality issues, time period, etc.
- This model assumes that 3.5/5 peaks will be achieved. With respect to Class A GA demand component for CED, the best that can be achieved is zero cost impact as savings are based on rate switch from Class B to Class A. Will require diligent monitoring and management given the significant cost of demand.
- We have included participation in another demand revenue generation stream referred to as Demand Response (DR). It is currently operating at \$50/kW. It is expected to increase significantly as local grids become constrained with electrification. The ECMs tailored around peak demand reduction provide U of T the unique opportunity to help improve the local Toronto Grid (Cecil TS). We have not yet included scheduling of the electric boiler (up to max operation < 45MW) but may elect to utilize, if necessary, to meet program goals.
- For the largest GHG ECM (90% of total) - CP-ECM-01 Electric Boiler - a monthly analysis was done first, followed by an hourly analysis, and then finally another hourly analysis by Jupiter that all aligns well. The next iteration planned to improve accuracy involves additional years of hourly analysis, including hourly central thermal data, and hourly GTG electric production.
- We have assumed the operation of the ice making chiller to be immaterial and have not included at this stage. We do recommend inclusion at the next stage of development.

5.1.2 Operational Cost

At this stage of the development for LEAP, we have only included utility and carbon costs and not operational cost impacts. We do recognize that we will need to include “differential” operational costs for ECMs that add new equipment for example such as Batteries, Solar PV, VSDs, Ice Storage, Solar Thermal, etc. We should also recognize that there will be ECMs that will reduce operational costs such as lighting and replacement of equipment like for like such as boilers, chillers, motors, BAS, etc. We need to be considering differential costs impacts over base year operational costs to accurately model the business case.

For a performance-based retrofit, we need to quantify differential costs from current operation. For example, replacement of equipment, like-for-like, a boiler-for-boiler, a pump-for-pump – should have no added costs as it should’ve already been maintained in the base case. If that’s not the case, we can address and determine the best method to address. However, we do expect an overall increase in maintenance and operational costs/requirements with this project.



Since we have taken a more conservative approach on having no material impact on the utility budget with utility costs with this project - we can increase savings contribution to be redirected to operations to cover expected increased differential costs. The next steps involve continued collaboration with the operations team to co-author the next detailed engineering phase and ensure we have included all costs and added resource requirements.

5.1.3 Summary ECMs

The following table itemizes all ECMs that are included in our preliminary analysis. These were selected as proof of concept with the following over-arching priorities:

- 1) Reduction of Scope 1 & 2 emissions by 46,000 tCO₂e annually (or 50% of total UTSG).
- 2) No material impact to the utility budget by using the Class A electricity rate structure and demand reduction strategies.
- 3) Meeting mandatory requirements. See Section 2.



Table 8: ECM Summary Table

Building/Area/Item	ECM ID	Measure	Electrical Savings					Thermal Savings			Saving Totals		Cost Est w/o TPC	
			kW ^{DR}	kW ^{GA}	kW ^{Pk}	kWh	tCO ₂ e	\$	MMBtu	tCO ₂ e	\$	tCO ₂ e		\$
BCIT (BA)	BA-ECM-01	Ice Storage System (3 hrs)	1,200	1,200	0	0	0	\$548,639	0	0	\$0	0	\$548,639	\$2,699,658
Convocation Hall (CH)	CH-ECM-01	Ice Storage Demonstration Measure	0	0	0	0	0	\$0	0	0	\$0	0	\$0	\$182,286
Central Heating Plant (CP)	CP-ECM-01	Add Electric Boilers	17,244	17,244	-17,244	-166,134,564	-4,984	-\$2,857,557	663,112	34,753	\$2,116,386	29,769	-\$741,172	\$11,947,036
Central Heating Plant (CP)	CP-ECM-02	CERT Carbon Emissions into Feedstock	0	0	0	0	0	\$0	0	0	\$0	0	\$0	\$0
Central Heating Plant (CP)	CP-ECM-03	Gas Turbine Inlet Air Cooling	0	1,100	0	150,000	5	-\$135,184	-1,024	-54	-\$3,267	-49	-\$138,451	\$1,565,838
Central Heating Plant (CP)	CP-ECM-04	Back Pressure Steam Turbine	500	500	0	50,000	2	-\$36,349	-341	-18	-\$1,089	-16	-\$37,438	\$689,042
Central Heating Plant (CP)	CP-ECM-05	Campus Wide Demand Management (6MW)	25	456	0	1,250	0	-\$54,462	-11	-1	-\$34	-1	-\$54,496	\$911,431
Central Heating Plant (CP)	CP-ECM-06	Battery Energy Storage System (3 hrs)	4,500	6,000	0	0	0	-\$507,959	0	0	\$0	0	-\$507,959	\$16,414,870
Central Heating Plant (CP)	CP-ECM-07	SEab Biodigester	0	0	0	0	0	\$0	0	0	\$0	0	\$0	\$2,039,782
Central Heating Plant (CP)	CP-ECM-08	Turn Off GTG and Operate for DR	5,471	0	-5,471	-47,379,888	-1,421	-\$267,035	240,259	12,592	\$766,808	11,170	\$499,774	\$0
Earth Sciences (ES)	ES-ECM-01	Upgrade Lighting to LED	0	88	88	877,288	26	\$122,014	-2,642	-138	-\$21,791	-112	\$100,224	\$426,550
Earth Sciences (ES)	ES-ECM-02	Heat Recovery Chiller	0	0	-75	-485,435	-15	-\$51,402	8,042	421	\$66,332	407	\$14,930	\$2,872,451
Earth Sciences (ES)	ES-ECM-03	Upgrade BAS, + DCV, and Recommission	0	124	124	494,753	15	\$109,627	2,595	136	\$21,405	151	\$131,033	\$1,822,862
Earth Sciences (ES)	ES-ECM-04	Conversion to LTHW	0	0	0	0	0	\$0	0	0	\$0	0	\$0	\$1,390,844
Earth Sciences (ES)	ES-ECM-05	Solar Thermal Water	0	0	0	0	0	\$0	0	0	\$0	0	\$0	\$0
Earth Sciences (ES)	ES-ECM-06	Solar PV	0	33	0	34,911	1	\$16,350	0	0	\$0	1	\$16,350	\$1,370,792
Earth Sciences (ES)	ES-ECM-07	Investigate Lab VAV/DCV	0	0	0	0	0	\$0	0	0	\$0	0	\$0	\$0
Earth Sciences (ES)	ES-ECM-08	Investigate Air Side to Water Side Free Cooling	0	0	0	0	0	\$0	0	0	\$0	0	\$0	\$0
CCBR (DC)	DC-ECM-01	Lighting Upgrade	0	90	90	781,320	23	\$67,948	-2,353	-123	-\$19,407	-100	\$48,541	\$271,606
CCBR (DC)	DC-ECM-02	Adiabatic Humidification (To be Vetted)	0	0	0	-863,264	-26	-\$20,118	8,839	463	\$72,904	437	\$52,787	\$300,772
CCBR (DC)	DC-ECM-03	LTHW Conversion	0	0	0	0	0	\$0	0	0	\$0	0	\$0	\$9,198,160
CCBR (DC)	DC-ECM-04	General VAV/DCV & Pump VFDs	0	0	0	487,900	15	\$11,370	4,295	225	\$35,426	240	\$46,796	\$576,024
CCBR (DC)	DC-ECM-05	Heat Recovery Chiller	0	0	-911	-3,073,497	-92	-\$204,191	31,469	1,649	\$259,563	1,557	\$55,372	\$4,848,812
CCBR (DC)	DC-ECM-06	Upgrade BAS and Commission	0	0	0	844,361	25	\$19,677	8,011	420	\$66,079	445	\$85,756	\$1,093,717
CCBR (DC)	DC-ECM-07	Battery Energy Storage System (3 hrs)	825	968	0	0	0	\$435,222	0	0	\$0	0	\$435,222	\$3,016,836
CCBR (DC)	DC-ECM-08	Investigate Lab VAV/DCV	0	0	0	0	0	\$0	0	0	\$0	0	\$0	\$0



ECM ID	Measure	Electrical Savings						Thermal Savings			Saving Totals		Cost Est w/o TPC
		kW ^{DR}	kW ^{GA}	kW ^{Pk}	kWh	tCO ₂ e	\$	MMBtu	tCO ₂ e	\$	tCO ₂ e	\$	
MC-ECM-01	Upgrade Lighting to LED in EX & OA	0	24	24	121,090	4	\$6,345	-146	-11	-\$3,165	-7	\$3,179	\$94,789
MC-ECM-02	McCaul Electrification with GSHP	0	0	-392	-1,325,863	-40	\$130,303	9,703	727	\$210,562	687	\$340,865	\$4,916,258
MC-ECM-03	Battery Energy Storage System (3 hrs)	750	1,000	0	0	0	\$37,500	0	0	\$0	0	\$37,500	\$2,743,407
MC-ECM-04	Combine Elect Service and Upgrade (+2MW)	0	0	0	0	0	\$0	0	0	\$0	0	\$0	\$4,593,612
MC-ECM-05	Electrify DHW (Subset of MC-ECM-02)	0	0	-113	-225,391	-7	-\$21,646	769	58	\$16,693	51	-\$4,953	\$0
MC-ECM-06	Upgrade BAS, + DCV and Recommission in HA	0	0	0	61,003	2	\$1,422	2,827	212	\$61,346	214	\$62,768	\$543,213
MC-ECM-07	Upgrade BAS, + DCV and Recommission in EX	0	0	0	33,844	1	\$789	158	12	\$3,422	13	\$4,210	\$236,972
MC-ECM-08	Upgrade BAS, + DCV and Recommission in OA	0	0	0	12,479	0	\$291	58	4	\$1,262	0	\$1,552	\$441,133
MC-ECM-09	Install Rooftop PV on HA	0	75	0	139,725	4	\$3,256	0	0	\$0	4	\$3,256	\$993,460
MC-ECM-10	Install Rooftop PV on OA	0	9	0	16,900	1	\$394	0	0	\$0	1	\$394	\$153,120
MC-ECM-11	Upgrade Heating Radiators in OA	0	0	0	0	0	\$0	0	0	\$0	0	\$0	\$0
MS-ECM-01	Ice Storage System (3 hrs)	3,760	3,760	0	0	0	-\$271,321	0	0	\$0	0	-\$271,321	\$8,175,535
MS-ECM-02	Operate Steam Chiller for GA 5CP	0	2,240	0	0	0	-\$273,638	0	0	\$0	0	-\$273,638	\$0
NW-ECM-01	Ice Storage System (3 hrs)	2,000	2,000	0	0	0	-\$144,320	0	0	\$0	0	-\$144,320	\$4,662,880
NW-ECM-02	Battery Energy Storage System (3 hrs)	1,500	1,600	0	0	0	-\$120,456	0	0	\$0	0	-\$120,456	\$4,024,879
PB-ECM-01	LTHW Conversion	0	0	0	0	0	\$0	0	0	\$0	0	\$0	\$2,056,188
PB-ECM-02	Adiabatic Humidification (To Be Vetted)	0	0	0	-243,258	-7	-\$5,669	2,491	131	\$20,544	123	\$14,875	\$304,418
PB-ECM-03	Heat Recovery Chiller	0	0	-195	-1,179,302	-35	-\$55,776	12,075	633	\$99,594	597	\$43,818	\$2,130,925
PB-ECM-04	Upgrade BAS, + DCV and Recommission	0	0	0	167,396	5	\$3,901	2,485	130	\$20,500	135	\$24,401	\$461,184
PB-ECM-05	Battery Energy Storage System (3 hrs)	375	242	0	0	0	\$117,243	0	0	\$0	0	\$117,243	\$1,376,261
PB-ECM-06	Investigate Lab VAV/DCV	0	0	0	0	0	\$0	0	0	\$0	0	\$0	\$0
VA-ECM-01	Battery Energy Storage System (3 hrs)	1,500	1,600	0	0	0	-\$120,456	0	0	\$0	0	-\$120,456	\$5,477,700
		39,600	40,400	-24,100	-216,636,000	-6,500	-\$3,515,000	990,700	52,200	\$3,790,000	45,700	\$274,800	\$107,025,000



5.2 Central Heating Plant (CP)

The original central heating plant was the second district heat and power plant commissioned in Canada in 1912 and delivered heating and power to 200,000 ft² over 20 buildings at the St. George Campus.

Today's 17 Russell St. Central heating plant was constructed in 1952 and has been expanded since this time to serve heating to 80% of the St. George campus.

5.2.1 Existing Conditions

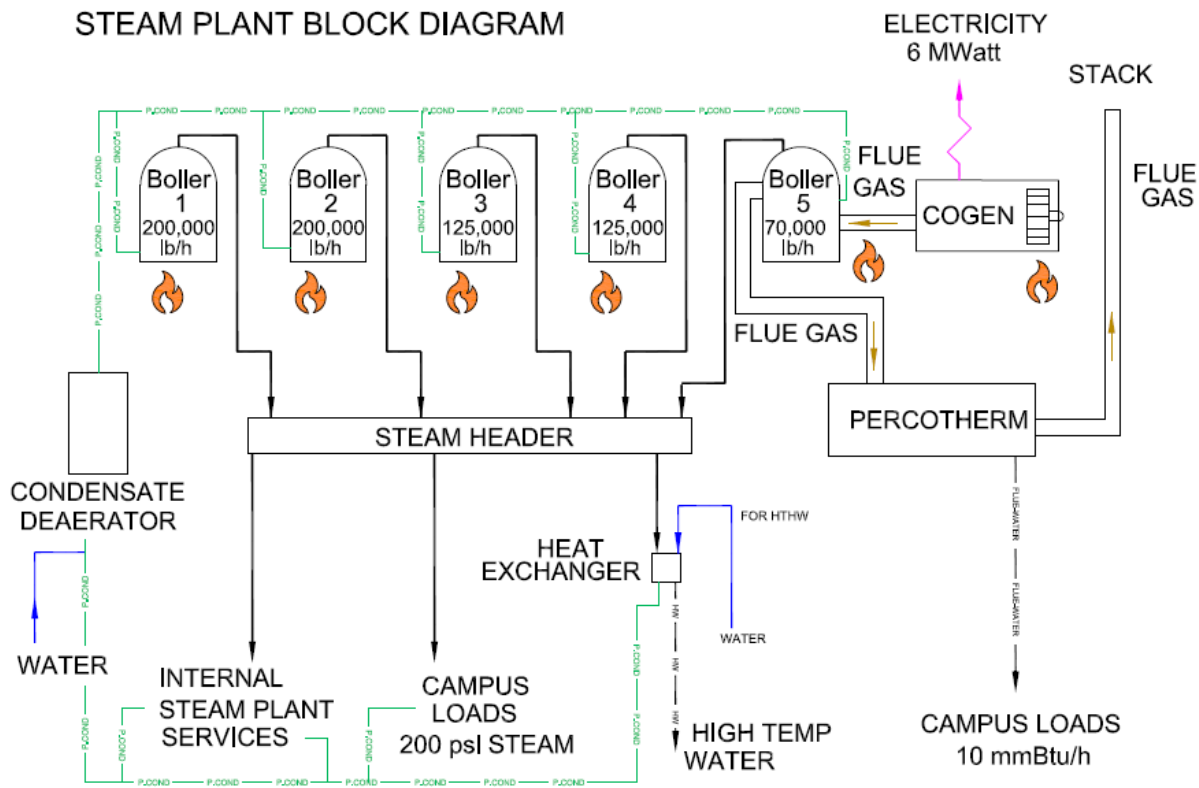

Figure 2: Central Steam Plant Block Diagram

The central steam plant is equipped with a 6.5MW gas turbine cogeneration unit which delivers both heating and electricity to the campus. The electricity from the cogeneration unit meets about 25% of the campus electricity consumption on an annual basis. The gas turbine was installed in 1992 and is in good state of repair.

In 2000, the central plant was equipped with a flue gas heat recovery system. The chimney is equipped with a Sofame direct contact Percotherm style unit. The recovery system is a combination of both direct contact as well as indirect via heat exchangers. This unit, in combination with flue gas hot water heat exchangers, produces 160°F hot water that is circulated to a small handful of buildings near the central plant right, including Lash Miller, MSB, Earth Sciences Centre & BCIT. Several initiatives have been launched to optimize the heat recovery system capacity, mostly focusing on lowering the return



temperature of this system. Heat recovery can also be found on the boiler blowdown to preheat boiler makeup water as well as flue gas economizers to pre-heat combustion air

The central plant is equipped with 4 Babcock & Wilcox steam boilers; the first two boilers were installed in 1960 and have a capacity of 125,000lbs/h of steam @ 200psig. The other two boilers were installed in 1967 and have a capacity of 200,000lbs/h. Boiler #5 is a heat recovery steam generator (HRSG) attached to the gas turbine and it supplies up to 28,000lbs/h in un-fired mode and 90,000 lbs/h in fully fired mode (with a duct burner).

The current mode of operation of the central plant is that the 6.5MW gas fired turbine operates in base mode, running as many hours as possible throughout the year. In the summer, boiler #5 is fired to meet the campus heating demand and in the winter, when capacity exceeds the fully fired capacity of boiler #5, the larger steam boilers are brought online to meet campus demand.

5.2.2 Energy Conservation Measures (ECMs)

The following measures are recommended for further analysis.

CP-ECM-01: Add Electric Boilers

a) Overview

This measure proposes the removal of a single dual-fuel boiler in the existing plant and adding two electric 45MW boilers to make use of renewable/low carbon electricity as a heating source. This single measure is the most impactful GHG reduction in the suite of upgrades and coupled with peak demand reduction ECM's is the backbone of the overall strategy.

Scope of Work:

This measure proposes to remove the existing Boiler #4 at the east end of the central heating plant. The existing boiler #4 is a Babcock & Wilcox steam boiler with a capacity 125,000 lb/h and was installed in 1960. This boiler currently operates with an approximate combustion efficiency of 83%. It can operate on dual fuel, natural gas and #2 oil. The average age of boilers #1-4 is 58 years, and although they are in operational condition, they need a renewal strategy. The American Society for Heating, Refrigeration and Air Conditioning Engineers (ASHRAE) has identified a typical service life for boilers to be approximately 30 years. Based upon the age of the boiler equipment within the steam plant, the University should begin implementing a renewal strategy. The yearly maximum recorded steam production peak was 283,000lbs/hr in the base year.

This measure proposes the installation of two Cleaver Brooks 45 MW electric steam boilers (to provide 2N redundancy) to be installed in place of the existing Boiler #4. The additional capacity from an electric boiler in the central plant allows for further diversity in fuel sources as well as for cost-effective operation, which will reduce carbon emissions. When the feeder capacity is increased in the future this will also allow for greater production on electric steam.



The proposed Cleaver Brooks electrode style steam boilers are 99.5% efficient and have a perfect turn down ratio of 100%. The concept is to operate these boilers so as to minimize additional peak hours so as to not impact the existing monthly peak demand of the CED. By not impacting the monthly peak demand charge the electric boilers are effectively generating steam at the average HOEP price of \$0.0233/kWh. This cost of 2.33 cents is cost competitive with natural gas an even more competitive when you consider the comparative efficiencies of the two systems (compare at \$0.0169/ekWh for natural gas), with the natural gas system having a penalty with only 83% efficiency.

For the Campus CED (Central Electrical Distribution), the current hourly average yearly demand without the Gas Turbine Generator (GTG) operating is 17,094kW. The maximum yearly CED peak without the GTG operating is 29,022kW (July summer peak). It is proposed to shut down the GTG and operate the electric boilers at an average yearly demand of 19,406kW or total continuous feed of 36,500kW (i.e., 17,094kW + 19,406kW = 36,500kW). It proposed to operate the electric boilers base loaded or up to the 36,500kW feeder capacity. What the electric boilers are unable to meet thermally, the remainder will be provided, or “trimmed”, with the remaining gas fired boilers.



Figure 3: Typical Electric Boiler

Based on operating the CED to 36,500kW continuously, U of T can achieve the desired 50% GHG reduction. It is proposed to connect the boilers to the 13.8kV electrical loop located beside the Central Steam Plant Building. There are 2 spare 2,000A @ 13.8kV breakers available for connecting (see 138000LoopsSLD for details).

U of T has applied to Toronto Hydro for confirmation is the supplied feeder can provide what it was intended to do or the full 2,000A @ 13,800kV or 47,748kVA, without requiring any major equipment modifications. We can adjust analysis depending on what Toronto Hydro has approved to provide (i.e., < 47,748kVA).

At the writing of this report U of T is conducting an engineering review to ensure feasibility and any upgrades necessary for electric boiler operation and connection to electrical infrastructure.

This measure shall also supply controls to allow for the desired mode of operation of these boilers. The intention is the new operation of the electric boilers will not add any new co-incident peak during its operation but will increase the overall utilization factor to 95% taking advantage of all the low-cost kWh available under the Class A tariff structure.

b) Economics and Other Benefits

Given the current “spark spread” of natural gas vs electrical rates there is an additional cost to operate the new proposed electric boilers vs natural gas. We have not included any operational costs at this stage but would expect there not to be any increases in differential operational costs of operating an electric boiler vs the natural gas and may even expect a slight decrease due to newness of boilers.



ECM ID	Electrical Savings						Thermal Savings			Saving Totals		Cost Est w/o TPC
	kW ^{DR}	kW ^{GA}	kW ^{Pk}	kWh	tCO ₂ e	\$	MMBtu	tCO ₂ e	\$	tCO ₂ e	\$	
CP-ECM-01	17,244	17,244	-17,244	-166,173,193	-4,985	-\$2,858,212	663,112	34,753	\$2,116,386	29,768	-\$741,827	\$11,947,036

c) Calculation Methodology

This is the largest GHG reduction ECM ~ 90% of total. A monthly analysis was done first, followed an hourly analysis, and then finally another hourly analysis by Jupiter that all align well.

The hourly analysis was modelled on base loading the new electric boilers and utilizing the existing gas fired for trimming. The new electric grid was capped below the electric feeder limits. The hourly gas and electricity were provided by the utility companies. The GTG electric + thermal was removed by modelling to leave the GTG thermal production only.

Savings are modeled upon switching from Class B to Class A and displacement of Class A coincident peak. Best case is achieving 5/5 peaks or no cost impact for the GA Demand component with the cost benefit based on the lower HOEP rate cost vs Class B rate cost. To be conservative, we have based our calculations on capturing 3.5 out of the 5 GA peaks. Should U of T achieve all 5/5 peaks the savings for the demand component would be zero and overall savings would be increased since we have only assumed 3.5/5 peaks.

d) Constructability

The equipment siting has not been finalized with no schematic designs preformed at this stage. However, there should be ample room with the removal of the existing Boiler #4 with the much smaller electric boilers. We do expect considerable effort in removal of Boiler #4 and have included costs accordingly.

Addition of two (2) Cleaver Brooks 45MW boilers installed with 2N redundancy onto an electrical system that is fed with a 45MVA supply raises concern with system overloading. Additional controls are proposed to address peak load control system to limit the total load to the available system capacity to prevent the overloading of the feeder and disconnection from the upstream transformer station. The peak load control system may have impacts on the existing electrical distribution equipment and will need thorough review during the detailed design phase.

With respect to the 13.8kV Switchgear/Breakers, the life over is not expected to fail over the next 5 to 10 years with nothing observed to believe otherwise. South of Boiler #4 breakers status have been updated and should have 10 years of life. However, there are concerns with the increased loading of the Switchgear/Breaker and it is recommended that a third party assessment be included in detailed engineering phase. **At the time of writing this Concept Report U of T has engaged K-Tec to do a preliminary review of the electrical infrastructure and the pre-feasibility of connecting the electric boilers to the 13,800kV loop.**

We will need to coordinate any equipment shutdowns with operations staff as separate exercise during detailed project delivery as part of the detailed engineering phase.

Asbestos removal has been estimated and included in the TPC for the U of T to remove.



CP-ECM-02: CERT - Carbon Capture

a) Overview

In addition to reducing GHG emissions, the university is testing and implementing innovative methods for carbon capture, sequestration, and use. Examples of U of T academic teams working with U of T operations to capture and use carbon and apply research to real world conditions are described below.

Professor David Sinton, Professor Ted Sargent, and the Carbon Electro catalytic Recycling Toronto (CERT) team are developing and scaling a system that uses solar-powered electricity to process water and CO₂ into ethylene feedstocks—the raw material most used to create petrochemicals. The CERT team is collaborating



Figure 4: CERT Pilot

carbon out of the boiler exhaust and convert it into



Figure 5: CERT Team

Objectives Supported

- *Build resilient low carbon systems*

Principals Applied

- *Balance carbon with cost*
- *Reach beyond our own assets*
- *Foster innovative solutions*

with U

of T to scale up technologies that capture and re-purpose CO₂ into valuable ethylene and ethanol feedstocks used around the world.

U of T Carbon Electro Catalytic Recycling Toronto (CERT) team, working under the supervision of Professor David Sinton and Professor Ted Sargent, Professor Geoffrey Ozin and the Solar Fuels team are working to turn CO₂ into biofuels using renewable solar energy to split the hydrogen out of water. Using their combination of photocatalytic technologies and expertise, they are working toward a way to take carbon out of the boiler exhaust and convert it into valuable biodiesels that would normally come from petroleum feedstocks. These and other game-changing solutions are being developed here with the assistance of our operations staff. The objective is to help us reduce our emissions and to get these technologies from the labs to a commercial setting.

Facility operations and services has been supporting the U of T X-Prize competitors; CERT (Carbon Electro catalytic Recycling Toronto). This team has developed technology to convert CO₂ into ethylene as well as other market products. We shall continue our support by allocating space within the central heating plant to accommodate their technology for



eventual integration with the central plant operations.

Scope of Work:

Space will be provided for research team to install their technology at the Central Plant with the removal of the Steam Boiler proposed in other ECM.

b) Economics and Other Benefits

We have not included any financials for this research measure in this project. We are excited to be part of this initiative with the Engineering Faculty research team.

ECM ID	Electrical Savings						Thermal Savings			Saving Totals		Cost Est w/o TPC
	kW ^{DR}	kW ^{GA}	kW ^{PK}	kWh	tCO2e	\$	MMBtu	tCO2e	\$	tCO2e	\$	
CP-ECM-02	0	0	0	0	0	\$0	0	0	\$0	0	\$0	\$0

c) Calculation Methodology

Measure financials are not included as this is a research project managed by the Faculty/Research team.

d) Constructability

No issues have been identified at this stage but will be addressed when more information is provided by the faculty on their requirements during the detailed engineering phase.

CP-ECM-03: Gas Turbine Inlet Air Cooling

a) Overview

When observing the power output of the cogeneration unit during the summer months we noticed a performance degradation due to the higher outdoor air temperature. The cogeneration is rated at 6-MW and this rating is at ISO conditions of 59°F, 60%RH.

When outdoor air temperatures exceeds 59°F, the lower density of the charge air results in a de-rating of the overall capacity of the cogeneration unit. When looking at output values plotted by the central plant operators, we see that the output of the cogeneration unit can drop to as low as 4.7MW during peak summer conditions when outdoor air temperatures are high. A common method for regaining this lost capacity is to cool the charge air well below 59°F to not only regain the lost capacity of the unit but also exceed the rated capacity.

Objectives Supported

- Renew existing and aged utility infrastructure
- Build resilient low carbon systems

Principals Applied

- Balance carbon with cost
- Reach beyond our own assets
- Foster innovative solutions



When analyzing the winter operation of the cogeneration at outdoor air temperatures below 59°F we see that the overall capacity can exceed 6MW, going as high as 6.4MW.

Scope of Work:

This measure proposes the installation of a cooling coil in the charge air intake of the cogeneration unit to cool the charge air down below 55°F.

There is an existing steel structure on the roof where the existing charge air intake is located, we look to



Figure 6: Potential Equipment Location

utilize the existing steel structure and add a cooling section to the existing charge air intake apparatus. The charge air cooling shall utilize a DX cooling coil rather than a chilled water coil as you have an extra 10 to 20% efficiency gain by avoiding an extra conversion to glycol mixture.

The charge air cooling system allows us to cool the charge air from hot summer temperatures more than 90°F down to below 55°F. This allows the cogeneration unit to climb from 4.7MW up to 6.4MW, resulting in a gross gain of 1.7MW, a net gain of 1.5MW after considering the cooling energy and additional losses.

The volume of charge air for the cogeneration unit has been calculated at 48,000 CFM to provide a cooling effect to drop the temperature from 100°F down to 30°F represents a delta T of 70°F leading to a requirement of 300-Tons of cooling and plus 50-Ton coil for ducted bearing cooling, and 100-Ton coil for generator enclosure and installation of a recirculation duct.

The condenser heat should be transferred to the low temperature hot water system, driving further

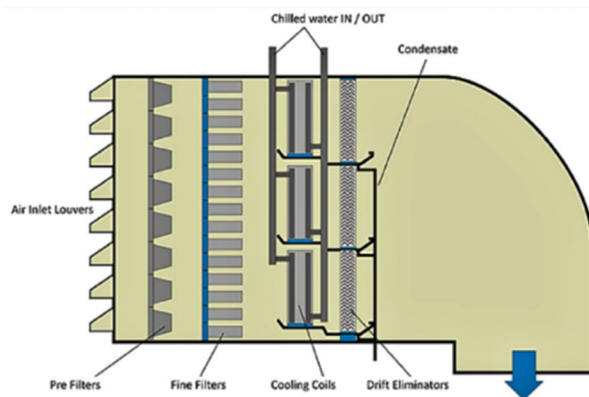

Figure 7: Inlet Air Cooling DX



savings on the capital cost of installation as well as natural gas savings.

This arrangement is favorable as it avoids extra capital cost for installing a cooling tower or dry cooler to reject the heat, this will also allow for the heat to be recovered if the cogeneration unit returns to continuous operation strategy.

As the denser air requires more natural gas to be combusted to create the additional power, we are intending for this to only operate when in demand response mode.

b) Economics and Other Benefits

The savings are focused solely on demand management and displacing GA peak events. This is net demand and includes the demand cooling requirements. We have not included any additional operating costs at this stage due to the very low hours of use but will review during detailed engineering phase.

ECM ID	Electrical Savings						Thermal Savings			Saving Totals		Cost Est w/o TPC
	kW ^{DR}	kW ^{GA}	kW ^{PK}	kWh	tCO ₂ e	\$	MMBtu	tCO ₂ e	\$	tCO ₂ e	\$	
CP-ECM-03	0	1,100	0	150,000	5	-\$135,183	-1,024	-54	-\$3,267	-49	-\$138,450	\$1,565,838

c) Calculation Methodology

Savings are modeled upon switching from Class B to Class A and displacement of Class A coincident peak. Best case is achieving 5/5 peaks or no cost impact for the GA Demand component with the cost benefit based on the lower HOEP rate cost vs Class B rate cost. To be conservative, we have based our calculations on capturing 3.5 out of the 5 GA peaks. Should U of T achieve all 5/5 peaks the savings would be zero and overall savings would be increased. We have also included 100 hours of run-time to be able to catch all 5 peaks.

d) Constructability

The equipment siting has not been finalized as we have not completed any schematic designs at this stage. However, there should be ample room to locate the condenser on the roof on the existing steel structure and there is plenty of room for ductwork. We will need to coordinate installation with GTG operation with a coordinated shutdown required for connecting.



CP-ECM-04: Back Pressure Steam Turbine

a) Overview

As part of the GGRP (Greenhouse Gas Campus Retrofits Program) project initiative 2 back pressure steam turbines were installed totaling 500-kW (2 x 250kW) in the central heating plant. These units suffered from a catastrophic failure upon start-up and the turbine itself has been removed from service.

Scope of Work:

Re-install the 500-kW (2 x 250kW) back pressure steam turbines in existing locations.



Figure 8: Removed Back Pressure Turbine in CSP

We have assumed that this will be connected in parallel to the grid and has already received local hydro approvals. This may need to be reviewed with Toronto Hydro as the electrical characteristics of the new turbine may be different. This will be revisited during the detailed engineering phase.

Objectives Supported

- Renew existing and aged utility infrastructure
- Build resilient low carbon systems

Principals Applied

- Balance carbon with cost
- Reach beyond our own assets
- Foster innovative solutions

b) Economics and Other Benefits

The savings are focused solely on demand management and displacing GA peak events. We have not included any additional operating costs at this stage due to the very low hours of use but will review during detailed engineering phase.

ECM ID	Electrical Savings						Thermal Savings			Saving Totals		Cost Est w/o TPC
	kW ^{DR}	kW ^{GA}	kW ^{PK}	kWh	tCO ₂ e	\$	MMBtu	tCO ₂ e	\$	tCO ₂ e	\$	
CP-ECM-04	500	500	0	50,000	2	-\$36,349	-341	-18	-\$1,089	-16	-\$37,438	\$689,042

c) Calculation Methodology

Savings are modeled upon switching from Class B to Class A and displacement of Class A coincident peak. Best case is achieving 5/5 peaks or no cost impact for the GA Demand component with the cost benefit based on the lower HOEP rate cost vs Class B rate cost. To be conservative, we have based our calculations on capturing 3.5 out of the 5 GA peaks. Should U of T achieve all 5/5 peaks the savings would be zero and overall savings would be increased. We have also included 100 hours of run-time to be able to catch all 5 peaks.



d) Constructability

This is a replacement of an existing non-functional steam turbine. The turbine will be selected to minimize piping connections and fit into existing layout. We don't expect any steam shutdowns and have assumed work to be done during regular hours.

CP-ECM-05: Campus Wide Demand Management

a) Overview

As a district energy and micro-grid operator, becoming a Class A customer represents an opportunity for the University of Toronto to centrally manage coincident peak demand and actively manage our GA costs. It is estimated that this represents an opportunity to save just under \$10M with demand response.

Demand response strategies aimed at reducing the coincident peak demand can effectively level the equivalent cost of natural gas versus electricity.

The more accurately that a Class A customer can predict the top five hours of peak demand and shift their demand accordingly, the more they will be able to take advantage of this initiative. The IESO publishes tools and information to help identify whether the forecasted peak demand for the next 24 hours could be a top 10 Ontario demand peak during the current base period.

Similarly, there are several service providers who monitor current demand and apply algorithms to accurately predict when a peak day will occur. Depending on the service provider, these predictions can be accurate to within 2-3 hours of the peak event. This tight accuracy allows for very aggressive measures to be implemented over a short period time with the intention of minimizing impact to the building occupants and processes. Given the significant opportunity in demand reduction it is recommended to work with at least 2 peak service providers to ensure no peaks are missed.

This is largely an operational measure that intends to implement a peak load predicting service or data to identify peak load parameters in HVAC and electrical systems in various buildings. This is a process more than it is physical upgrades, but this will have an impact on building systems as the process evolves and iterates. BAS controls upgrades, submetering enhancements, variable speed drives upgrades, enhanced control, monitoring and trend logging in general will be required to reach optimum performance over time. Operationally, this will also require operational resources in expert staff and management to provide continuous implementation, operation, assessment and revaluation of measures. A well-managed process has potential to greatly reduce peak demand and save energy as well.

Objectives Supported

- *Build resilient low carbon systems*

Principals Applied

- *Balance carbon with cost*
- *Reach beyond our own assets*
- *Foster innovative solutions*



In summary the following strategies are recommended for integration into the BAS:

- Cooling setpoint adjustment – Lower setpoint before peak and allow setpoint to rise during event call. For example, sub cool to 21°C and then raise to 24°C during call event
- Precool the chilled water system by lowering setpoint before event call and again allowing setpoint to rise. For example, sub cool to 5°C and raise to 10°C. In addition:
 - Limit chiller demand
 - Cooling valve limit
- Where applicable reduce fan, air handler, or pump speed.
- Increase SAT
- Fan VFD limit
- Pump VFD limit or schedule
- Fan duct static reset
- Pump static reset
- Prior to demand event call pre-charge spaces with outside air (~500ppm) and during event call raise CO2 to an accepted value (~ 900ppm)
- Schedule all electrical equipment like electric DHW during event call
- Consider lowering light levels or turning off during event call

Temporary experimentation in disabling the systems identified during hours in which are identified as high potential of being Global Adjustment hours is considered the next best step and witnessing the associated drop in electrical demand during the hours to corroborate the estimations made in this report.

Once these temporary adjustments are performed and the actual power savings specifically identified, and any “pain points” identified as a result of the tests further understood, a permanent automated solution including the automatic application of the load roll function by connection to a third-party prediction service can be further investigated.

The proposed summarized list of items to pursue as next steps are:

- 1) Perform further investigation on the actual power impact realized through manual testing, as well as further investigation of space level impact of demand response.
- 2) Establish and issue a scope of work for the extension of the demand response function to be implemented based on the effectiveness realized in Step 1.
- 3) Determine next steps for BAS sequences optimization

As indicated above, this is largely an operational measure to reduce peak consumption at predefined times. Consideration will be given to the addition of permanent metering (if not already installed) on all



main feeders to distribution points throughout the campus to better understand and track the energy consumption.

b) Economics and Other Benefits

The savings are focused solely on demand management and displacing GA peak events. Savings are modeled upon switching from Class B to Class A and displacement of Class A coincident peak. Best case is achieving 5/5 peaks or no cost impact for the GA Demand component with the cost benefit based on the lower HOEP rate cost vs Class B rate cost. To be conservative, we have based our calculations on capturing 3.5 out of the 5 GA peaks. Should U of T achieve all 5/5 peaks the savings would be zero and overall savings would be increased.

ECM ID	Electrical Savings						Thermal Savings			Saving Totals		Cost Est w/o TPC
	kW ^{DR}	kW ^{GA}	kW ^{PK}	kWh	tCO ₂ e	\$	MMBtu	tCO ₂ e	\$	tCO ₂ e	\$	
CP-ECM-05	25	456	0	1,250	0	-\$54,462	-11	-1	-\$34	-1	-\$54,496	\$911,431

c) Calculation Methodology

We have assumed a conservative 1MW of potential demand reduction during a GA peak period. We expect that upwards of 30% are possible of demand peak mitigation. In addition, we have included only 3.5 of the 5 peaks financially as a conservative approach.

d) Constructability

This measure will require further input from U of T stakeholders. This measure requires significant tuning and commissioning to ensure the demand reduction operates as specified to maximize demand reduction.



CP-ECM-06: Battery Energy Storage System (BESS)

a) Overview

To further enable demand response and GA avoidance 6 MWh hours of battery storage will be installed in the central heating plant. The batteries will be purchased in a self-contained unit and installed in a stacked manner near the electrical infrastructure. The 18MWh of capacity will provide 6MW of demand response capacity or potentially 1MW of emergency back-up for up to 18 hours for the CED.

There are multiple benefits to the battery storage systems as they can be charged overnight when electricity is both cheap and clean with a lower carbon content than the

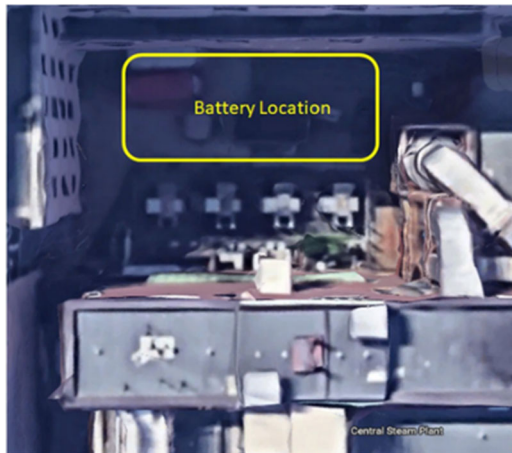

Figure 9: Potential BESS Location

and displacing GA peak events.

c) Calculation Methodology

With respect the demand component of Class A: Best case is achieving 5/5 peaks or no cost impact for the GA Demand component with the cost benefit based on the lower HOEP rate cost vs Class B rate cost. To be conservative, we have based our calculations on capturing 3.5 out of the 5 GA peaks. Should U of T achieve all 5/5 peaks the savings would be zero and overall project savings would be increased.

Objectives Supported

- Build resilient low carbon systems

Principals Applied

- Balance carbon with cost
- Reach beyond our own assets
- Foster innovative solutions

marginal during daytime operation. The conversion efficiency of the batteries is also very high at over 90%. Containerized solutions provide an advantage for noise mitigation and the ability to relocate generator in future to accommodate relocation of the Central Plant and/or Nodal Plant Design.

Scope of Work:

Supply a containerized BESS solution 6MW @ 3 hours (18MWh) batteries with required HVAC, controls, etc. We are also proposing to integrate into a new SCADA system.

b) Economics and Other Benefits

The savings are focused solely on demand management

ECM ID	Electrical Savings						Thermal Savings			Saving Totals		Cost Est w/o TPC
	kW ^{DR}	kW ^{GA}	kW ^{PK}	kWh	tCO _{2e}	\$	MMBtu	tCO _{2e}	\$	tCO _{2e}	\$	
CP-ECM-06	4,500	6,000	0	0	0	-\$507,959	0	0	\$0	0	-\$507,959	\$16,414,870



d) Constructability

The equipment siting has not been finalized. There is space around Central Steam plant and on the roof of the transformers. There a previous measure being investigated for additional GTG (+10MW), and the roof was selected as a viable option. Will need to maintain access to the Campus transformers to the North of the potential location,

We have assumed a “typical” installation with reasonable proximity to an electrical connection and no added structural work or the like. Since these are a based on containerized solution, they can relocate to suit best siting.

CP-ECM-07: SEab Biodigester (Waste-to-fuel)

a) Overview

There is an opportunity to incorporate a small, modular bio digester system adjacent to the existing central plant to feed renewable natural gas into the boiler plant. A preliminary study has been completed by U of T students as part of the campus as a living lab program to evaluate the applicability of a small bio digester to consume food and organic waste on campus.

The SEab "Flexibuster" takes organic food waste and adds some "bugs" to create biogas that is cleaned and utilized to produce electricity and heating hot water from

the
internal



Figure 10: Containerized Solution

combustion engine. There is also water - 80% of organic waste is water - and fertilizer byproducts from the process. There is no storage of biogas as it's consumed directly in the unit to produce heat and power. While there are additional Scope 3 GHG reductions from reduced trucking and potentially landfill emissions - they're not included in our submission.

Scope of Work:

The scope of this measure is to purchase and install a “Flexibuster” FB120 module by SEaB bio digester module, or equivalent, and install in the unit adjacent to the central plant (next to the batteries) with the biogas being fed to the existing CHP and boilers.

Objectives Supported

- Build resilient low carbon systems

Principals Applied

- Balance carbon with cost
- Reach beyond our own assets
- Foster innovative solutions



b) Economics and Other Benefits

The economics do not include potential savings for avoided disposal. We also have not included the added costs in operations at this stage. We would expect additional operation costs to be offset by savings in utility and disposal costs savings, but further analysis is required. Added operational requirements and costs will be developed and included in detailed engineering phase or next stage.

ECM ID	Electrical Savings						Thermal Savings			Saving Totals		Cost Est w/o TPC
	kW ^{DR}	kW ^{GA}	kW ^{Pk}	kWh	tCO2e	\$	MMBtu	tCO2e	\$	tCO2e	\$	
CP-ECM-07	0	0	0	0	0	\$0	0	0	\$0	0	\$0	\$2,039,782

c) Calculation Methodology

Savings were provided by SEaB.

SEaB
energy

Important: the output figures of an anaerobic digester are entirely dependent on feedstock composition, quality and consistency. Consequently, the output figures given here are purely provided as an illustration, and cannot be taken as a guarantee of output.

Customer
Date: **06/02/2019**
SEaB Power Ltd Company Confidential

Waste Type Food waste

Quantity 2,500 kgs/day

SEaB FLEXIBUSTER™

CAPEX

System	347,941 €
CHP	57,841 €
Installation	7,974 €

OPEX

Maintenance	7,590 €/yr
-------------	------------

Electricity Rate 0.14 €/kWh

Heat Rate 0.06 €/kWh

Cost of Waste Disposal 80.00 €/tonne

Feed-in-tariff 0.00 €/kWh
Heat Incentive 0.00 €/kWh
Grants 0.00 €
Carbon Credit 25.00 €

System for Your site

1x FB 120
CA 50kW

Total electrical production 346,387 kWh/yr
Parasitic electrical requireme 37,876 kWh/yr
Electricity available to site 308,511 kWh/yr

Total Heat Production 635,043 kWh/yr
Parasitic Heat Requirement 112,473 kWh/yr
Heat available to site 522,569 kWh/yr

Liquid fertiliser 724 tonnes/yr

SAVINGS

Electricity	43,192 €/yr
Heat	31,354 €/yr
Waste disposal	73,000 €/yr

NEW INCOMES

Feed-in-tariff	- €/yr
Heat Incentive	- €/yr
Grants	#REF! €
Carbon credits	8,541 €/yr
Fertiliser	21,732 €/yr

Payback **2 year(s)**

www.seabenergy.com

+44 (0)20 3003 5066

newinfo@seabenergy.com

d) Constructability

The equipment siting has not been finalized. There is space around Central Steam plant and on the roof of the transformers. We will need to maintain equipment routing for removal and replacement.



We have assumed a typical installation with proximity to both an electrical connection and hot water connection with no added structural work or the like. Since these are based on containerized solution, they can be relocated to suit siting conditions to achieve optimized design.

CP-ECM-08: Operate Gas Turbine Generator (GTG) for Demand Response

a) Overview

The Gas Turbine Electric Generator (GTG) is currently operated continuously and provides about 32% of the CED electrical load. It is expected to have a service life on no more than about 10 years if operated continuously. The generator has never been replaced but the turbine has been refurbished as per manufacturer's recommendation.

As part of the electrification of the Central Heating Plant we are proposing to change GTG from continuous to peak operation. Additional thermal load will be provided from electric and gas boilers. The additional electric load will be provided by the relatively clean Ontario grid.

The proposed operation should enable the life of the GTG to be extended due to significantly reduced run hours (100 hrs/yr as compared to approx. 8700 hrs/yr) and managing cycle rate so as to not increase from current operation.

Scope of Work:

Operate GTG to displace GA Peak event or other demand response event. Limit GTG cycles and allow minimum run times to those recommended by manufacturer one GTG is operated. The GTG is currently cycled at about 40 to 50 times per year. We are recommending cycles be kept well below this amount. We may also need to consider lay-up requirements for extended periods of when the GTG is shut down.

b) Economics and Other Benefits

Savings are based on turning off the GTG and are modeled upon switching from Class B to Class A and displacement of Class A coincident peak. No added operational costs are expected. Service life of GTG should be extended due to significant reduction in operation if cycling rate is optimized.

Objectives Supported

- Build resilient low carbon systems

Principals Applied

- Balance carbon with cost

ECM ID	Electrical Savings						Thermal Savings			Saving Totals		Cost Est w/o TPC
	kW ^{DR}	kW ^{GA}	kW ^{PK}	kWh	tCO ₂ e	\$	MMBtu	tCO ₂ e	\$	tCO ₂ e	\$	
CP-ECM-08	5,471	0	-5,471	-47,379,888	-1,421	-\$267,281	240,259	12,592	\$766,808	11,170	\$499,528	\$0



c) Calculation Methodology

With respect to the demand component of Class A: Best case is achieving 5/5 peaks or no cost impact for the GA Demand component with the cost benefit based on the lower HOEP rate cost vs Class B rate cost. To be conservative, we have based our calculations on capturing 3.5 out of the 5 GA peaks. We have also included 100 hours of run-time to be able to catch all 5 peaks.

d) Constructability

None expected as this involves the modification in operation of an existing asset.



5.3 Earth Sciences (ES)

The Earth Sciences building is a 5-floor academic and research building built in 1988 on the University of Toronto St. George campus at 33 Willcocks Ave. The building has a total floor area of 32,664 m² (351,600 SF) over 5 floors with a basement and features research labs, offices, classrooms/lecture spaces and greenhouses on the roof.

5.3.1 Existing Conditions

Mechanical Systems

The mechanical systems serving the building is a hydronic based 4-pipe heating and cooling plant system providing building heating and cooling via four (4) 100% AHUs providing make-up air for laboratory fume hood and general exhaust systems, nine (9) mixed AHUs providing non-lab space ventilation and interior zone temperature control, 4-pipe fan coil units for local temperature control and perimeter radiation for exterior zones not served by FCUs. The laboratory fume hood exhaust system is a non-centralized system consisting of 106 fume hood exhaust fans, each serving a single fume hood, or in some cases up to four fume hoods. The laboratory general exhaust system consists of multiple centralized systems of ten (10) exhaust fans serving local labs.

The building greenhouses are heated and cooled from the building heating and cooling system and is provided with back-up heating via an emergency gas-fired boiler.

There have been several major system and minor zone level renovations over the years. The following paragraphs provide a more detailed description and understanding of the mechanical systems, including the major system renovations that have altered the original design of the mechanical systems.

Heating Plant

The original 1989 heating plant in the building is served by the campus district high temperature hot water (HTHW) as shown in Figure 11. The HTHW enters the building in Mechanical Room B123 where it connects to the building via two (2) HTHW-to-heating hot water shell & tube heat exchangers (HX-1 and HX-2). These heat exchangers are hadronically arranged in a primary-secondary piping system providing heating hot water at 82.2°C (180°F) in the primary loop (P-9/P-10) to two secondary hot water loops: 1) air handling unit (AHU) heating coils loop (P-13/P-14); and 2) fan coil unit (FCUs) in building (P-11/P-12).

1996 Heating System Renovation:

In 1996, the heating plant underwent a renovation to connect the heating plant to the campus district Sofame (LTHW) system as shown in Figure 12. The LTHW enters the building in Mechanical Room B123 where it connects to the building via two plate & flame heat exchangers (HX-6 and HX-7). Heat exchanger HX-6 was integrated to the AHU secondary loop and HX-7 was integrated to the FCU hydronic secondary loop.

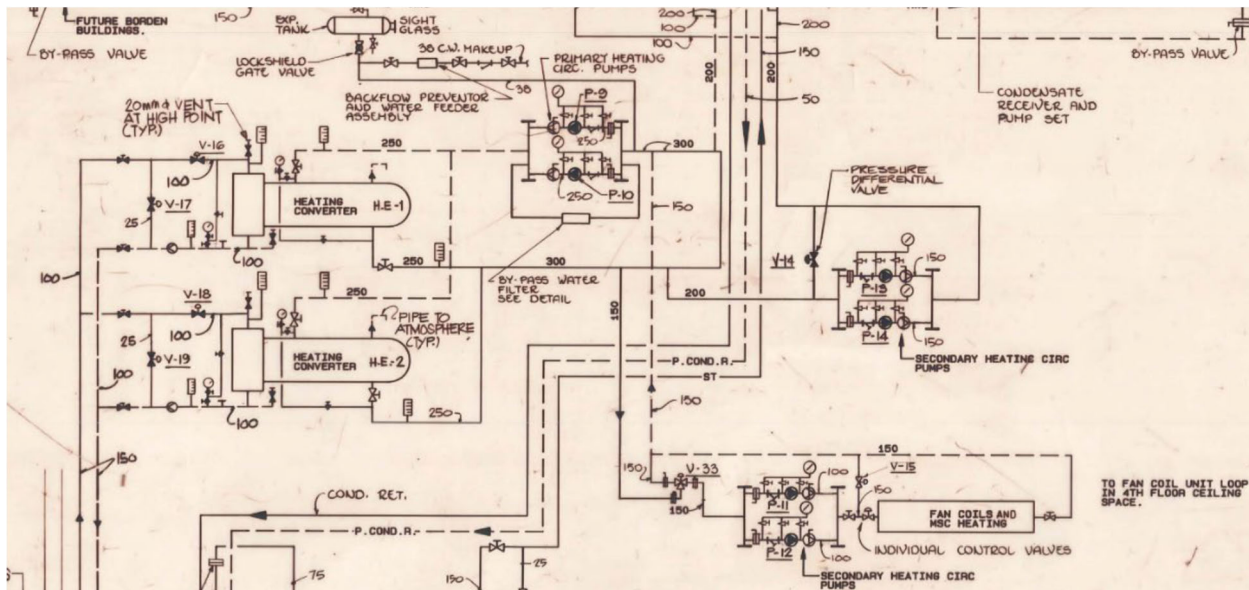

Figure 11: HTHW

To support operation of the heating system on LTHW, the renovation also executed the following modifications:

- Replacement of the heating coils located in the several AHUs, including SF-1, SF-3, SF-5, SF-6, SF-7, SF-9, and SF-11 with low supply water temperature 54.4°C (130°F) heating coils.
- Install glycol (50% ethylene glycol) feed system on the AHU secondary heating loop; and
- Installation of a plate & frame heat exchanger (HE-11) and piping modifications to hydraulically segregate the new glycol AHU secondary loop from the primary heating loop while maintaining supplemental heat from the district HTHW.

It is our understanding that the remaining AHUs (SF-2, SF-4, SF-8, SF-10, SF-12 and SF-13) heating coils were not replaced. As a result, the AHU heating loop is not able to operate at a low supply water temperature of 54.4°C (130°F) during most of the winter season. The heating hot water temperature is manually reset as high as 71°C (160°F) to maintain the AHU discharge air temperatures, thus removing the efficiency of operating on the LTHW. Additionally, the LTHW heat exchanger HX-6 was only sized for 25 l/s (400GPM), a fraction of the system peak design flow rate of 44.1l/s (700GPM).

It is our understanding that the FCU heating coils and perimeter radiation, which are designed for 82.2° C (180°F) supply water temperature, were not converted to low temperature heaters that could effectively operate on LTHW. As a result of the FCU loop temperature being greater than the LTHW, this system is not able to operate on LTHW during the winter season. During our site investigation it was noted that the LTHW heat exchanger (HX-7) was isolated on the LTHW source side with a valve and pad lock to prevent its operation.

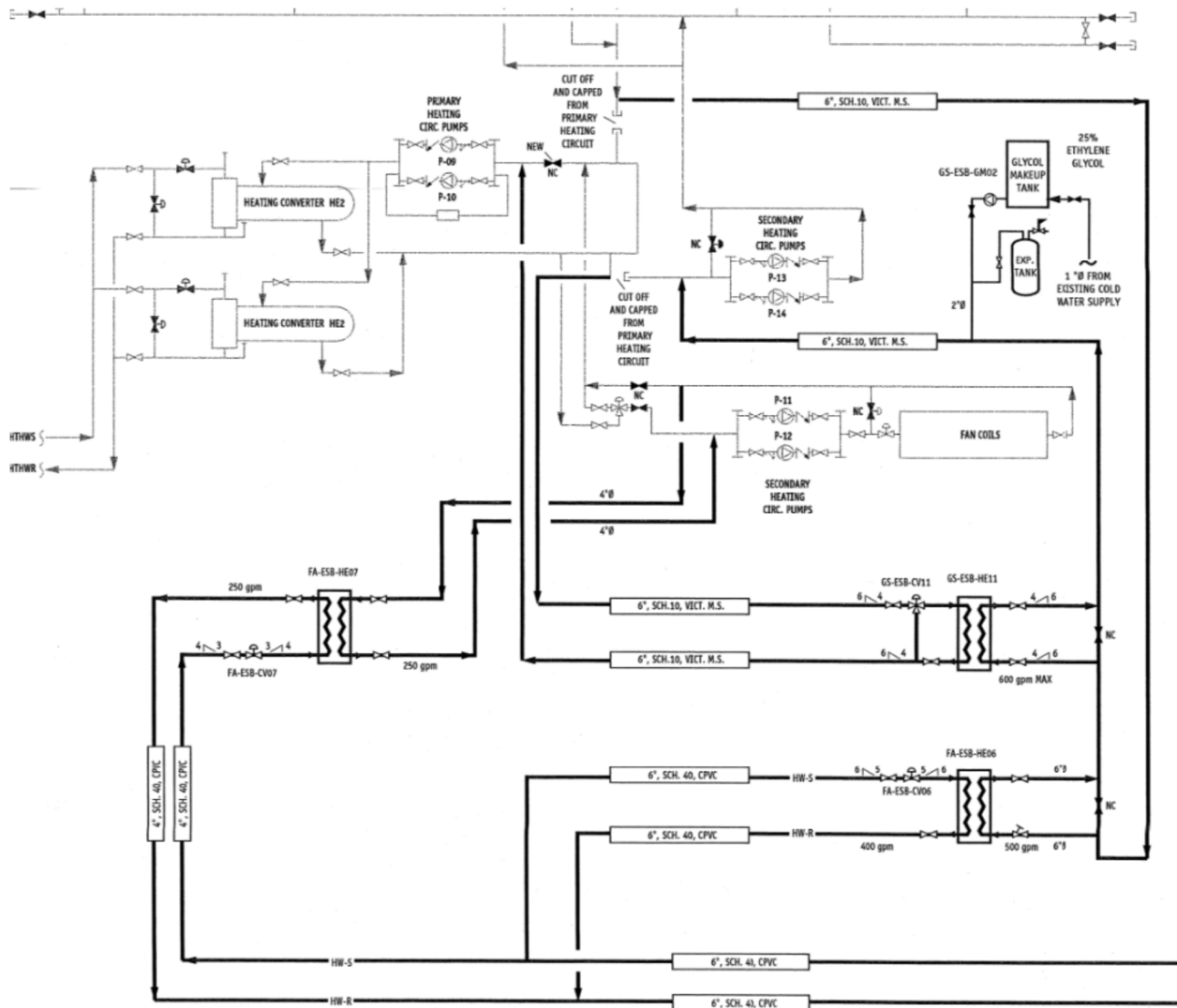

Figure 12: Sofame & LTHW

2001 Greenhouse Renovation:

In 2001, a greenhouse addition introduced a new secondary heating loop (P-3/P-4) connected to the primary heating loop for heating the greenhouse. The heating pumps were installed in the basement mechanical room and heating pipe to and from the greenhouse heating system. The system is backed up by a gas-fired boiler located in Mechanical Room 529. The boiler is designed to operate in the event the district HTHW is out of service.



2015 HTHW Heat Exchanger Replacement:

In 2015, one of the two shell & tube HTHW heat exchangers (HX-1/HX-2) was replaced with two (2) brazed plate heat exchangers (scheduled as HX-2a/HX-2b in this report). Heat exchanger HX-1 remains for back-up service.

Chiller Plant

The original 1989 chiller plant consists of an on-site chiller plant complete with two (2) 800-ton water-cooled chillers (CH-1/CH-2), two (2) cooling towers (CT-1/CT-2) with a water-side economizer plate & frame heat exchanger (HE-3) as shown in

Figure 13. The condenser water pumps (P-7/P-8) circulate condenser water through the chillers and, depending on the season, the economizer heat exchanger (HE-3). The chiller evaporators are hydronically arranged in a primary-secondary piping system providing chilled water at 6.7° C (44°F) in the primary loop (P-1/P-2) to two secondary chilled water loops: 1) air handling unit (AHU) cooling coils loop (P-5/P-6); and 2) fan coil unit (FCUs) in building (P-3/P-4). The economizer heat exchangers are connected the FCU loop to provide waterside economizing during the winter months.

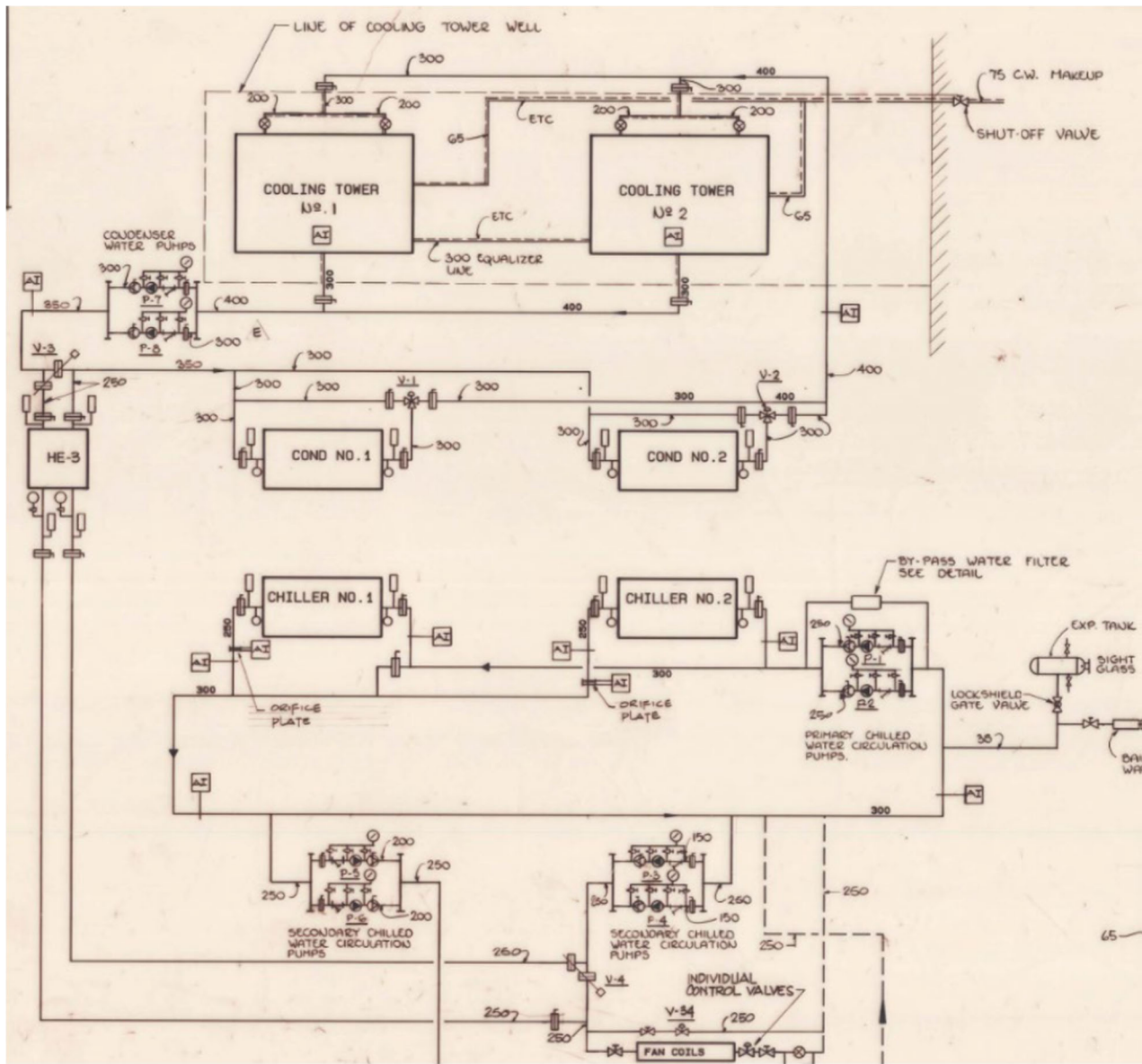

Figure 13: Chiller Plant Schematic

2008 Chiller Replacement:

The existing original chillers were replaced in 2008 with York chillers and the piping was configured to allow the chiller condensers to be bypassed during economizer operation as shown in Figure 14.

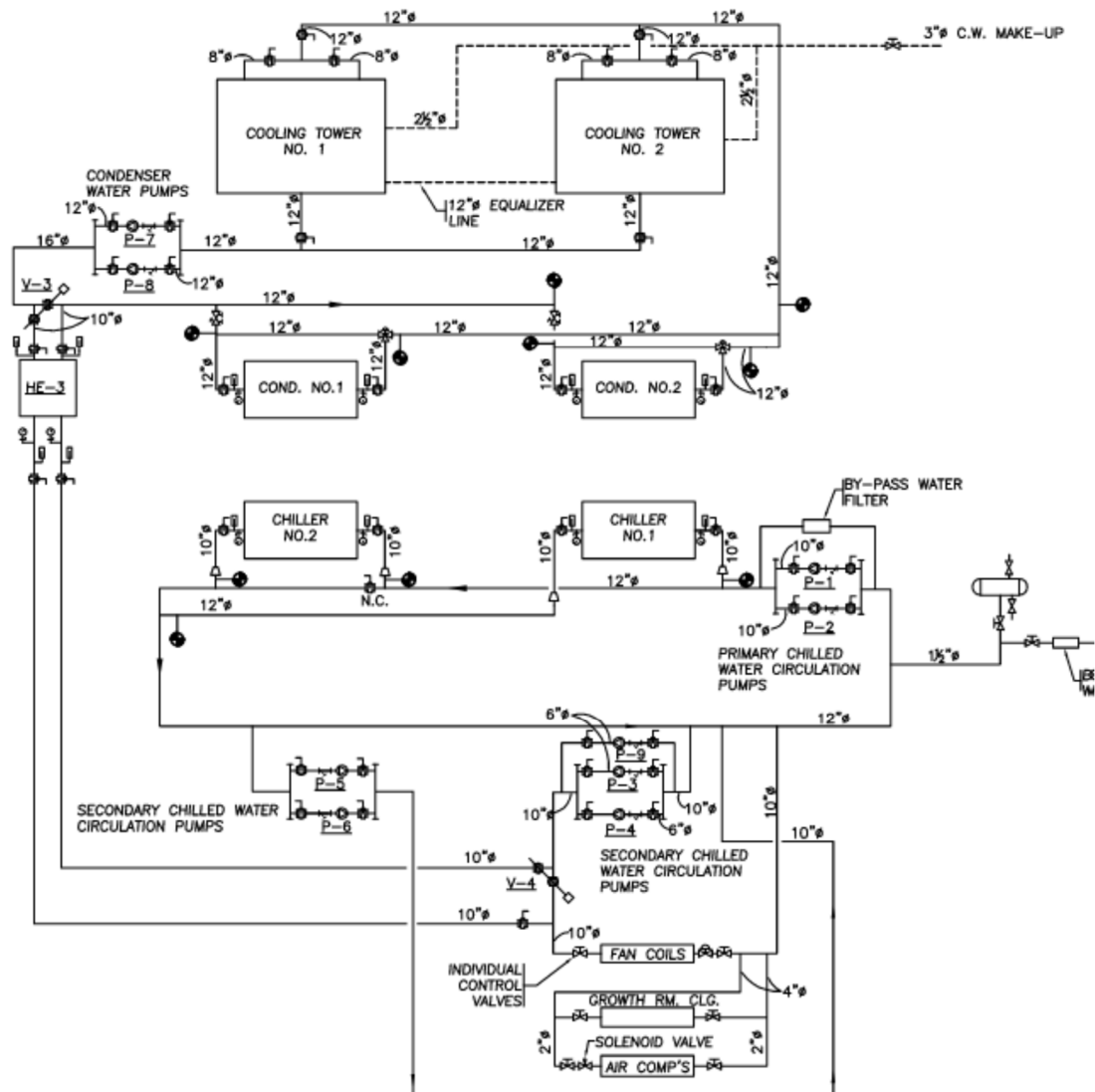

Figure 14: York Chiller Upgrade 2008

Air Handling Systems

There are 13 existing custom-built AHUs in the building (SF-1 through SF-13). They are a combination of 100% outside air systems for labs, and re-circulating systems for non-lab spaces as summarized in the following existing AHU schedule:



Table 9: Air Handler Schedule

TAG	LOCATION	SERVES	AIRFLOW (CFM)
SF-1	S HURON BLOCK MECH ROOM B155	100% OA – BASEMENT, LEVEL 1 to 4 LAB SPACES (SOUTH)	30500
SF-2	S HURON BLOCK MECH ROOM B155	MIXED AIR – BASEMENT, LEVEL 1 TO 4 CORRIDORS & OFFICE SPACES. SERVED BY RETURN FAN RF-1 (SOUTH)	28000
SF-3	N HURON BLOCK MECH ROOM B123	100% OA - LEVEL 1 to 4 LAB SPACES (NORTH)	38000
SF-4	N HURON BLOCK MECH ROOM B123	MIXED AIR – BASEMENT, LEVEL 1 TO 4 CORRIDORS & OFFICE SPACES. SERVED BY RETURN FAN RF-2 (NORTH)	15000
SF-5	WILCOCKS BLOCK MECH ROOM B113	MIXED AIR – BASEMENT, LEVEL 1 TO 4 CORRIDORS & OFFICE SPACES. SERVED BY RETURN FAN RF-3 (NORTH)	26000
SF-6	WILCOCKS BLOCK	100% OA – LEVEL 2 AND 4 LABS, DARK ROOMS, POTTING ROOM (NORTH)	16000
	MECH ROOM B113		
SF-7	FORESTRY BLOCK MECHANICAL PENTHOUSE	100% OA - LEVEL 1 to 4 LAB SPACES (WEST)	21000
SF-8	FORESTRY BLOCK MECHANICAL PENTHOUSE	MIXED AIR - LEVEL 1 TO 4 CORRIDORS & OFFICE SPACES. SERVED BY RETURN FAN RF-4 (WEST)	6000
SF-9	SHARED FACILITIES MECH ROOM B151	MIXED AIR – LEVEL 1 THEATRE. SERVED BY RETURN FAN RF-5	10000
SF-10	SHARED FACILITIES MECH ROOM B151	MIXED AIR – LEVEL 2 LIBRARY. SERVED BY RETURN FAN RF-6	22000
SF-11	SHARED FACILITIES MECH ROOM B151	MIXED AIR – BASEMENT, LEVEL 1 AUDITORIUM, CLASSROOMS, WASHROOMS. SERVED BY RETURN FAN RF-7	16000
SF-12	WILCOCKS BLOCK MECH ROOM B113	MIXED AIR – BASMENT GROWTH FACILITIES (NORTH). SERVED BY RETURN FAN RF-8	11100
SF-13	N HURON BLOCK MECH ROOM B123	MIXED AIR – BASMENT GROWTH FACILITIES (NORTH-EAST). SERVED BY RETURN FAN RF-9	9000

- All labs are supplied with 100% fresh air units (AH#1,3,6 &7) with terminal Phoenix valves, running 24/7. The labs are served also with general exhaust fans, total of 5. There is more than one general exhaust fan per corresponding AHU. The general exhaust is constant volume. There approximately



108 fume hoods in the labs that are controlled locally (Phoenix) by variable drives for the fume hood, maintain face velocity depending on the sash position. The pressurization in the lab is maintained by modulating supply air Phoenix valve based on the set volumetric offset and the fume hood exhaust.

- All offices, classrooms, library, and common spaces are ventilated by AH #2, 4, 5, 8, 9, 10, 11, 12, 13, and 14 with return air and fan coils/ VAV to maintain the comfort temperature
 - All these fans are scheduled to be turned off between 10 pm – 6 am.
 - Lecture rooms fans are controlled by schedule provided by OSM

1996 Heating System Renovation:

In 1996, SF-1, SF-3, SF-5, SF-6, SF-7, SF-9, and SF-11 were retrofitted with low temperature supply glycol 54.4°C (130°F) heating coils. The heating coil circulating pumps were removed for all the AHUs. The fan inlet vanes were locked open and VFDs were added for speed control.

Zone Level Systems

Lab with Fume Hoods

Labs with fume hood(s) are served with dedicated lab exhaust fans located in the penthouse and make-up air from one of the four 100% make-up AHUs via a pneumatic controlled venturi valve. See Figure 15 for example of a lab layout with fume hood. In Figure 16 the supply is highlighted in purple, and the fume hood is highlighted in green. The fume hoods, associated exhaust fans and make-up air venturi valves are provided with a first-generation Phoenix control system. The system is stand-alone for each lab and includes a fume hood sash monitor, exhaust fan speed controller (VFD) and make-up supply air venturi valve(s). The controls were designed to vary the speed of the exhaust fan and make-up air venturi valve based on maintaining a constant sash face velocity as fume hood sash position is changed.

The supply make-up air is delivered at room neutral temperature to the lab indirectly via the lab plenum space and an egg-crate ceiling grille.

Temperature control within the lab is maintained by a 4-pipe chilled & hot water fan coil unit.

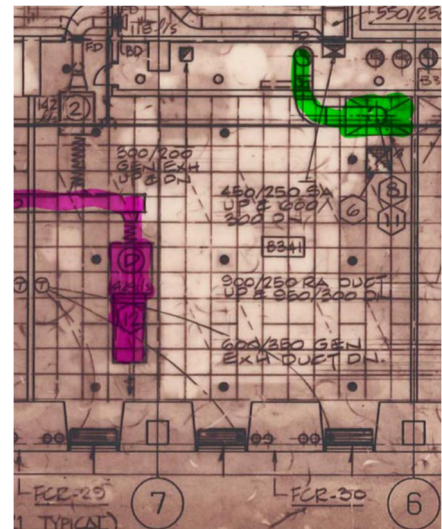

Figure 15: Lab with Fume Hoods Layout



Lab with General Exhaust

Labs with general exhaust are served centrally by multi-zone exhaust fans located in the penthouse and make-up air from one of the four 100% make-up AHUs via a constant volume (CV) air terminal. See Figure 16 for example of a lab layout with constant volume general exhaust. In Figure 16 the supply is highlighted in purple, and the general exhaust is highlighted in green. The exhaust fans run at constant speed to provide a constant exhaust and ventilation to the lab space.

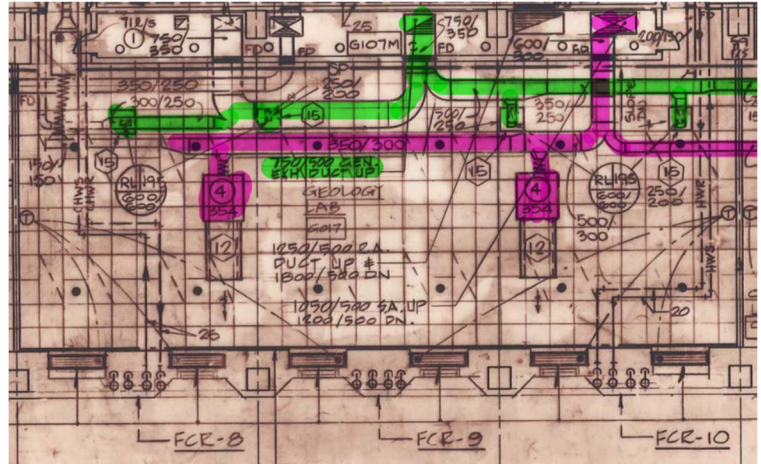

Figure 16: Lab with General Exhaust Layout

The exhaust is ducted directly to exhaust grilles in the lab and supply make-up air is delivered at room neutral temperature to the lab indirectly via the lab plenum space and an egg-crate ceiling grille.

Temperature control within the lab is maintained by a 4-pipe chilled & hot water fan coil unit.

Lan Renovations

Throughout the years, select labs in the building have gone through renovations. Many of these renovations are localized, re-use existing equipment, and do not have an impact on the overall systems of the building. There are two exceptions, including the Mirriam Diamond Lab renovation (2016) and the KrKosek Lab renovation (2019).

The Mirriam Diamond Lab renovation involved the installation of multiple pieces of equipment. These include: a dedicated outdoor air rooftop unit (RTU), an exhaust fan, fume hoods, canopy hoods, and FCUs. This lab is stand-alone and currently not visible through the energy management and reporting system (EMRS).

The KrKosek Lab renovation is currently the only lab on the EMRS. The renovation involved the removal of a fume hood and associated make-up air venturi valve, and replacement with a VAV terminal unit. This renovation also provided new motor starters and controllers to the existing building.



Offices and Common Spaces

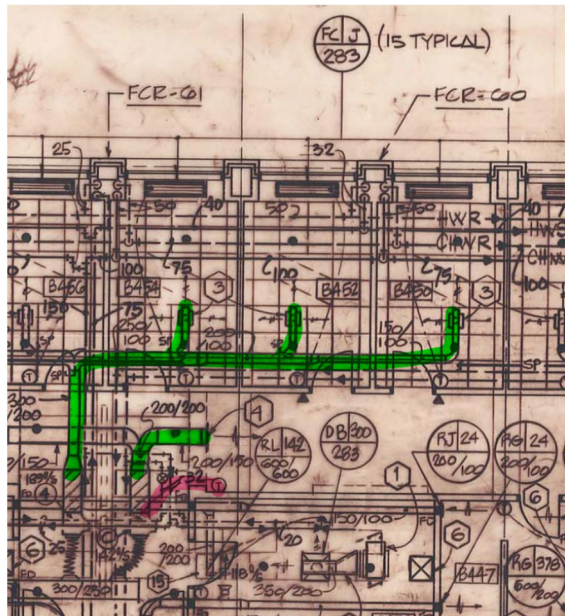

Figure 17: Common Spaces Layout

Office Spaces: Office spaces have supply air from associated AHU via zoned pneumatic CV terminal units and plenum return air. See Figure 16 for example of the offices and common spaces. In Figure 16 the supply air is highlighted green and the VAV thermostat is highlighted purple. Temperature control within each office is maintained by a 4-pipe chilled & hot water fan coil unit.

Common Interior Zone Spaces: Common interior zone spaces have supply air from associated AHU via zoned pneumatic VAV terminal units and plenum return air. Temperature control in these areas is maintained by the VAV terminal unit.

Building Automation System (BAS)

In the late 1990s, the University of Toronto implemented the Central Control and Monitoring System (CCMS) primarily to monitor performance of main mechanical systems. The controls implemented through CCMS provided operational staff the ability to schedule operation of the controlled mechanical equipment to provide operations cost savings.

Over the past several years, the CCMS system was replaced with the Energy Management and Reporting System (EMRS).

The original mechanical controls system installed is pneumatic controls. There have been several mechanical retrofits to the building over the years that have resulted in retrofit of controls in the building. These include but are not limited to the following:

- 1) Introduction of a central control and monitoring system (CCMS),
- 2) Lab and office renovations which have installed new DDC controllers to the building.
- 3) FCU motor control VIA IP1836 energy management units,
- 4) Addition of BTU meters to the building,
- 5) The campus wide introduction of Honeywell’s Enterprise Management and Reporting System (EMRS).

Growth Chambers

There is a growth chamber located in the Basement – North Side. It serves faculty of Botany. It originally had 8 walk-in growth chambers with standalone heating + DX water cooling system, now there are 65 growth chambers with standalone heating + DX water cooling. DX water cooling units are cooled by central year around chilled water (cascade, return from the building)



Compressors for all the growth chambers, cooled by central year around chilled water (cascade, return from the building). Chilled water cooling has a city water back up

Electrical Systems

The Earth Sciences Building is fed from University of Toronto Steam Plant's 13.8kV HV Loop, via 750MCM, 15kV Cables routed in duct banks.

There are two main 600/347V distribution substations located in the basement main electrical room and on the 4th floor penthouse electrical room. Each substation is fed from two 1.5 MVA transformers, called T3 and T4, into a double ended switchboard configuration. The penthouse 600/347V, 3000A switchboard 'BBB' is fed from T3 and T4 and was observed on site to have peak demand of 357kW and 444kW respectively, based on metering data visible on the switchboard.

Emergency power is provided through a 400kW, 600V, 60Hz, diesel generator on the 4th floor generator room.

Satellite electrical rooms with 600/347V and 208/120V normal power distribution are on floors 1,3, and 5. Satellite electrical rooms on basement, 2nd floor, and 4th floor have 600/347V and 208/120V normal and emergency power distribution.

The information used to develop our understanding of the existing system are as follows:

1. University of Toronto Facilities and Services UESCO Earth Science Deep Retrofit ECM & Scope Report - Revision 12 (January 27, 2020)
2. Earth Sciences Centre - Project 83053
 - a. Drawing E1-01 – Revision I (November 21, 1986)
 - b. Drawing E5-01 – Revision H (November 22, 1988)
3. Rushby Energy U of T Earth Sciences Lighting Audit – Final V2
4. Site visit performed on November 24, 2020

IT/Communications

Existing Telecom Rooms within the Earth Sciences Building will be utilized for termination of new cables on this project. The Telecom Rooms utilized will be dependent on the location of the new BAS devices, ensuring that the length of all new 4-pair UTP cables are within 90m of an existing room.

It is assumed the currently capacity of the existing LAN network is sufficient to support the additions of this project. Any expansions of the LAN (copper/fiber backbone) will be coordinated with the UT Central IT department in coordination with F&S IT as the project progresses.

A future site visit of the existing Telecom Rooms in the building will be conducted to further verify the existing equipment capacities, determine whether any expansion of equipment be required (i.e., patch



panels, switches and/or 2-post racks) and coordinate with the UT Central IT department in coordination with F&S IT as the project progresses.

Other Services

Compressed air for Lab + Control supplied centrally by MSB with backup air compressor.

Steam (from central steam plant) is used for autoclaves in botany and pressure treated wood in Forestry department. It used also to serve for AHU humidification but has not been in service for years.

For the main domestic hot water heating, main source is high temperature water with Sofame preheat, there is a backup electrical hot water heating.

Domestic cold water has a booster pump.

There is also Central R.O. Water system.

5.3.2 Energy Conservation Measures (ECMs)

The following ECMs are proposed for implementation at Earth Sciences.

ES-ECM-01: Upgrade Lighting to LED

a) Overview

We recommend conversion of the existing greenhouse lighting with highly efficient LED lighting. Estimated 50% reduction of current use, or 5% of the total electrical consumption.

Scope of Work:

Greenhouse LED Conversion and remaining building LEDs:

- Replace 371 x 465W HPS lamps with 371 x 300W Galaxyhydro plant growth lamps, replace 181 x 400W HID lamps with 181 x 250W LED plant growth lamps.
- Re-use power cables, same voltage, pendant mounted from the ceiling space, at final height of ~ 8ft high.

b) Economics and Other Benefits

We have only included utility savings and have also taken into consideration both the cooling effect reduction and added heating load. We have not included any operational savings.

Objectives Supported

- *Build resilient low carbon systems*
- *Renew existing and aged utility infrastructure*

Principals Applied

- *Balance carbon with cost*
- *Reach beyond our own assets*
- *Foster innovative solutions*



ECM ID	Electrical Savings						Thermal Savings			Saving Totals		Cost Est w/o TPC
	kW ^{DR}	kW ^{GA}	kW ^{PK}	kWh	tCO ₂ e	\$	MMBtu	tCO ₂ e	\$	tCO ₂ e	\$	
ES-ECM-01	0	88	88	877,288	26	\$122,014	-2,642	-138	-\$21,791	-112	\$100,224	\$426,550

c) Calculation Methodology

Savings have been estimated based on estimated lighting power density and LED retrofits with system operating continuously.

d) Constructability

We have assumed the work will be done during regular working hours or during low occupancy periods. We will install this measure in many areas of the facility including in academic areas so that requires careful coordination. We will create a detailed communication and delivery plan due to the nature of this installation, before work commences.

ES-ECM-02: Heat Recovery Chiller

a) Overview

This ECM proposes to installation of a new 140-Ton heat recovery chiller (HRCH-1) that is sized to handle simultaneous summer heating loads in the building. The hot water from the HRCH will be utilized to heat the FCU loop during the summer months whenever the FCU loop can operate at 54°C (135°F) supply water temperature or less. This operation will be managed by automatic change-over valves.

The HRCH will also be utilized to inject heat into the AHU loop via a hot water-to-glycol plate & frame heat exchanger (HRC-HE1) to preheat the AHU return glycol temperature whenever there is a sufficient simultaneous cooling load in the winter months or shoulder seasons.

Scope of Work:

1) Install new HRCH on Level 4 roof and provide associated structural reinforcement (Refer to Section 9 – Structural Modifications) and architectural enclosure (Refer to Section 10 – Architectural Modifications).

Objectives Supported

- Build resilient low carbon systems
- Renew existing and aged utility infrastructure

Principals Applied

- Balance carbon with cost
- Reach beyond our own assets
- Foster innovative solutions



2) Install new HRCH evaporator pumps (HRC-P1/HRC-P2) on Level 4 roof within same new enclosure housing the HRCH and run new chilled water piping to/from HRCH to chilled water primary loop.

3) Install new HRCH condenser pumps (HRC-P3/HRC-P4) in basement mechanical room B123 and run new hot water piping to/from the heating water AHU secondary loop and FCU loop.

4) Replace old HTHW shell & tube heat exchanger HE-1 in basement mechanical room B123 with a new brazed plate heat exchanger. The new heat exchanger will provide back-up to the two heat exchangers (HE-2a/2b) and expand available real estate to facilitate installation of the new HRCH condenser pumps HRC-P3/HRC-P4 and new heat exchanger HRC-HX1.

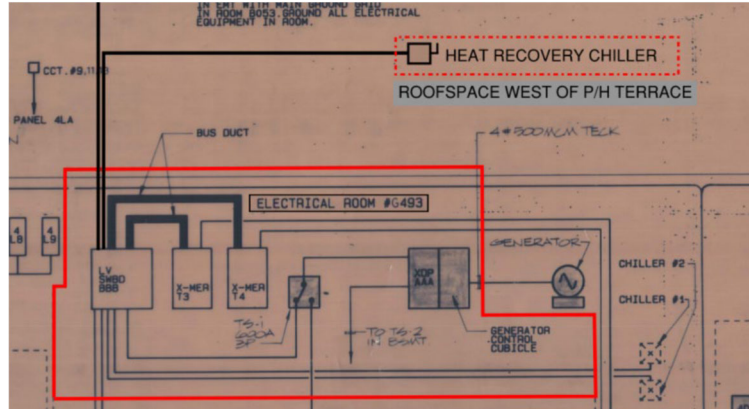

Figure 18: Heat Recovery Chiller Electrical

5) Add a new unit heater for space heating of new HRCH room.

6) Add a new floor drain & associated sanitary drain piping and connection to local sanitary drain.

7) Add a new roof drain & associated storm drain piping and connection to local storm drain.

8) The additional heat recovery chiller will be fed from an existing low voltage switchboard BBB located on the penthouse electrical room. New breaker is required as existing board and breakers are obsolete.

9) Two 5 HP chilled pumps (duty/standby) will also be located next to the chiller and will be fed from MCC #1 from the penthouse mechanical room.

Alternate Scope of Work

During the next phase we propose investigation additional heat recovery and increasing HRCH size accordingly. Along with that analysis we propose replacing an existing chiller with a HRCH that would also address capital renewal and mandatory requirements.

b) Economics and Other Benefits

We have only included the utility savings and not any added operational costs for the operation of the chiller during the winter.

ECM ID	Electrical Savings						Thermal Savings			Saving Totals		Cost Est w/o TPC
	kW ^{DR}	kW ^{GA}	kW ^{PK}	kWh	tCO2e	\$	MMBtu	tCO2e	\$	tCO2e	\$	
ES-ECM-02	0	0	-75	-485,435	-15	-\$51,402	8,042	421	\$66,332	407	\$14,930	\$2,872,451



c) Calculation Methodology

We have assumed the HRC operates continuously at close to full load. Calculation aligns with Arup’s model and savings.

d) Constructability

Arup has provided a schematic design with siting and required structural and electrically design for this ECM. This design forms the basis of the costing submitted to the costing consulting.

ES-ECM-03: Upgrade BAS, +DVC, and Recommission

a) Overview

The design intent is to upgrade the existing Building Automation system (BAS).

All work shall be in accordance with the latest University of Toronto – Building Automation Systems - Design Standards and Guidelines.

The upgrade shall replace the existing mainly pneumatic and Central Control and Monitoring System (CCMS) building automaton system and select existing standalone controllers with a new Direct Digital Control BAS.

The new BAS shall be integrated with the existing Energy Management and Reporting System (EMRS).

The new BAS shall include the capacity to carry out typical BAS fault detection and diagnostics at the controller level.

Scope of Work:

The new BAS controls work shall comprise of instrumentation, final control elements, BAS control panels, temporary workstation, programming, controls wiring, communications network wiring and associated power wiring.

The scope related to the removal of existing system and components include the following:

- Demolition of the JCI CCMS MUX controllers and cabinets
- Demolition of portions of the pneumatic controls no longer needed, including controllers, E/P and sensors.
- Replace existing electric to pneumatic (E/P) controllers with new E/P

Objectives Supported

- *Build resilient low carbon systems*
- *Renew existing and aged utility infrastructure*

Principals Applied

- *Balance carbon with cost*
- *Reach beyond our own assets*
- *Foster innovative solutions*



- Replacement of existing damper/actuators and valve/actuators were determined non-functional per audit assessment.

Replacement of existing electronic sensors. The scope related to the installation of the new DDC BAS system and components include the following:

- New intelligent DDC-BACnet controllers connected via a BACnet network. DDC controllers of modular design, allowing for future expansion of control and monitoring points.
- New temporary operator's workstation inclusive of graphic displays, and printer.
- The BAS will employ BACnet communications protocol and all DDC hardware will be native BACnet.
- The BAS shall be integrated to multiple systems and equipment including variable speed drives, chillers, boilers and other equipment provided with original equipment manufacturer (OEM) controllers.
- Integration of the new BAS with the existing EMRS

The BAS will provide control and monitoring of the following building systems and functions:

- Air Handling Units
- Variable Air Volume (VAV) boxes
- Fan Coil Units (FCU)
- Supply Fans
- Exhaust Fans
- Laboratory Fume Hood Systems
- Laboratory Supply Air Valves
- Valve and Dampers
- Cooling Tower
- Chiller System
- Boilers
- Heat Exchangers
- Sofame System
- Electrical Metering
- Energy Metering
- Monitoring of Space conditions
- Monitoring of Outdoor conditions
- Emergency generator system.
- Condensate dump tank



- Soffit heating units
- Truck dock heaters
- Sump pumps
- AHU Steam Humidifiers
- Programmed start-stop of systems.
- Critical Alarm Annunciation.
- Preventative maintenance alarms.
- Sequential start-up of plant following power loss
- Operating logs.
- Trend logs and forecasting

b) Economics and Other Benefits

We have only included utility savings and no operational savings at this stage.

ECM ID	Electrical Savings						Thermal Savings			Saving Totals		Cost Est w/o TPC
	kW ^{DR}	kW ^{GA}	kW ^{PK}	kWh	tCO ₂ e	\$	MMBtu	tCO ₂ e	\$	tCO ₂ e	\$	
ES-ECM-03	0	124	124	494,753	15	\$109,627	2,595	136	\$21,405	151	\$131,033	\$1,822,862

c) Calculation Methodology

We have calculated savings based on a 15% reduction of the HVAC loads as per energy balance.

d) Constructability

Costing is based on previous BAS retrofits at the university. We propose to install this measure in many areas of the facility including in academic areas so that requires careful coordination. We will create a detailed communication and delivery plan due to the nature of this installation, before work commences during the detailed engineering phase.



ES-ECM-04: Conversion to LTHW

a) Overview

This ECM proposes to make modifications to the existing AHU heating system to allow the system to operate more exclusively on LTHW for energy savings. The current design limits operation on LTHW due to three major design deficiencies: 1) the ability for the AHUs to maintain supply air temperature during the winter months when operating on LTHW; 2) the LTHW heat exchanger (HX-6) at 3150kW (10 800MBH) is undersized by 1670kW (5712MBH) to meet the design capacity of the AHU heating system; 3) the LTHW heat exchanger (HX-7) is not capable of maintaining the FCU loop design temperature and is currently locked in isolation from the FCU loop.

Objectives Supported

- *Build resilient low carbon systems*
- *Renew existing and aged utility infrastructure*

Principals Applied

- *Balance carbon with cost*
- *Reach beyond our own assets*
- *Foster innovative solutions*

The first deficiency will be corrected by ensuring that all the heating coils connected to the AHU loop can meet design supply air temperatures with LTHW coils, including replacing the remaining existing AHU 82.2°C (180°F) coils with LTHW heating coils based on 54.4°C (130°F) heating glycol supply and 32.2°C (90°F) heating glycol return temperature.

The second deficiency will be corrected by upsizing the LTHW heat exchanger heating capacity to match the connected heating load of 4816 kW (16 512 MBH) and increasing the pipeline size connecting the LTHW heat exchanger to the AHU heating loop from 150mm (6") to 200mm (8").

The third deficiency will be corrected by adding automatic controls to only allow LTHW to be utilized on the FCU loop when the FCU heating supply water temperature is reset to 57.2°C (135°F) or less.

The scope of work for this ECM include:

- 1) Replace heating coils in the following AHUs: SF-2, SF-4, SF-8, SF-10, SF-12 and SF-13 with new LTHW heating glycol coils.
- 2) Replace HE-6 with new 5298 kW (18,163 MBH) plate & frame heat exchanger.
- 3) Replace undersized 150mm (6") heating pipe 200mm (8") heating pipe.
- 4) Add automatic controls to prevent unwanted operation of LTHW heat exchanger HX-7.

b) Economics and Other Benefits

We have not included any utility reduction benefit at this stage. This ECM is designed around future opportunities to utilize either Nodal LTWH or additional EAHR.



ECM ID	Electrical Savings						Thermal Savings			Saving Totals		Cost Est w/o TPC
	kW ^{DR}	kW ^{GA}	kW ^{PK}	kWh	tCO2e	\$	MMBtu	tCO2e	\$	tCO2e	\$	
ES-ECM-04	0	0	0	0	0	\$0	0	0	\$0	0	\$0	\$1,390,844

c) Calculation Methodology

We have not included any utility reduction benefit at this stage.

d) Constructability

Arup has provided a schematic design with siting and required structural and electrically design for this ECM. This design forms the basis of the costing submitted to the costing consulting. We will install this measure in many areas of the facility including in academic areas so that requires careful coordination. We will create a detailed communication and delivery plan due to the nature of this installation, before work commences.

ES-ECM-05: Solar Thermal Water

a) Overview

There are several existing domestic hot water heating systems strategically located around the building. Based on our site visit and discussion with the building operator, these systems have recently been converted from steam-to-domestic hot water generators to electric tank-type water heaters as recently as 2020.

This ECM proposes installing a Solar Thermal system complete with flat-plate solar collectors to centrally pre-heat domestic the domestic cold-water supply prior to supplying the domestic hot water tanks. The system will include a total of 18 flat-plate collectors located on the chiller room roof. The collectors are connected with a glycol piping loop and circulating pump to a brazed plate or double-wall heat exchanger. The load side of the brazed plate or double-double wall heat exchanger is connected to three (3) domestic hot water storage tanks that pre-heat incoming domestic cold water. The circulating pumps, heat exchangers, and storage tanks will be provided as a packaged system and located in the penthouse mechanical

Objectives Supported

- Build resilient low carbon systems
- Add Renewable Content

Principals Applied

- Balance carbon with cost
- Reach beyond our own assets
- Foster innovative solutions

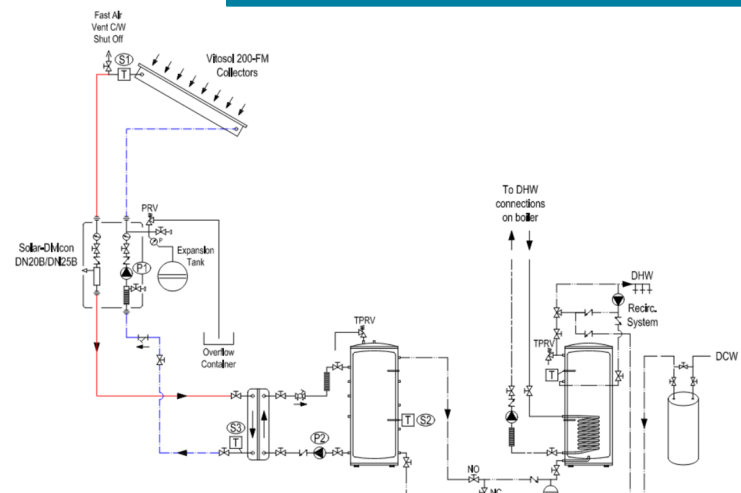

Figure 19; Solar Thermal Schematic



room. The pre-heated domestic water is distributed from the storage tanks to each domestic hot water heater in the building.

Scope of Work:

The scope of work for the ECM include:

- 1) Install 18 flat-plate solar thermal collectors on the chiller roof with structural reinforcement.
- 2) Install pump stations with hot water three (3) 175-gallon storage tanks, expansion tank and heat exchangers.
- 3) Run glycol piping to/from solar thermal collectors.
- 4) Run 50mm (2") domestic cold water from basement mechanical room to storage tank.
- 5) Run 50mm (2") pre-heated domestic hot water to each domestic hot water heater in the building

b) Economics and Other Benefits

We have only included the utility savings at this stage but do appreciate there will be a need for operational tasks to maintain system including the glycol renewal. This added cost will be included during the detailed engineering phase.

Measure is not included in project financials.

ECM ID	Electrical Savings						Thermal Savings			Saving Totals		Cost Est w/o TPC
	kW ^{DR}	kW ^{GA}	kW ^{Pk}	kWh	tCO2e	\$	MMBtu	tCO2e	\$	tCO2e	\$	
ES-ECM-05	0	0	0	0	0	\$0	0	0	\$0	0	\$0	\$0

c) Calculation Methodology

Savings are taken from Arup’s modelling.

d) Constructability

We have had Arup provide a schematic design with siting and required structural and electrically design for this ECM. This design forms the basis of the costing submitted to the costing consulting.



ES-ECM-06: Solar PV

a) Overview

A new solar panel system is introduced on top of the building roof (5th floor level). The expected weight of the panel's assembly weighs 20 psf minimum to resist wind uplift forces. The proposed locations for these panels have no allowance for this additional load (Refer to Section 6 for proposed locations).

Accordingly, a raised platform is introduced to support the new panels assembly where the additional loads will be directed to the vertical elements without imposing any loads on the existing beams and slabs, as depicted in Figure 15. The final layout of the raised platform and the supporting points will be determined based on the final layout of the solar panels.

Objectives Supported

- Build resilient low carbon systems
- Add renewable content

Principals Applied

- Balance carbon with cost
- Foster innovative solutions

Scope of Work:

Using the roof spaces on the Mechanical penthouse and South Huron Block, the solar PV option can provide 35kW of solar energy. The system shall be complete with:

- Approx. 107 – 330W PV panels
- 50kW, outdoor rated inverter installed on the roof
- Outdoor rated rapid shutdown box
- Outdoor rated DC disconnect and combiner
- All necessary requirements from LDC

b) Economics and Other Benefits

Savings are based on displacing the electric usage at the site based on parallel grid operation. We have not included the additional operational costs at this stage. We do expect additional operational cost to maintain this system and for costs required for equipment renewal such as the invertors.

ECM ID	Electrical Savings						Thermal Savings			Saving Totals		Cost Est w/o TPC
	kW ^{DR}	kW ^{GA}	kW ^{PK}	kWh	tCO2e	\$	MMBtu	tCO2e	\$	tCO2e	\$	
ES-ECM-06	0	33	0	34,911	1	\$16,350	0	0	\$0	1	\$16,350	\$1,370,792

c) Calculation Methodology

Savings are taken from Arup's modelling.



d) Constructability

Arup has provided a schematic design with siting and required structural and electrically design for this ECM. This design forms the basis of the costing submitted to the costing consulting. This will require utility approval for connection.

ES-ECM-07: Investigate Lab VAV/DCV

a) Overview

The very nature of work being conducted in research facilities requires proper ventilation needs to be maintained to ensure a safe environment for all occupants. And the energy consumption of labs must be taken into consideration when planning energy efficiency initiatives.

Maintaining 100% fresh air ventilation in a life science facility translates into large amounts of energy being consumed. There is an opportunity to introduce Demand Control Ventilation in the Labs, by implementing a Lab Demand Control Ventilation (DCV) system. Basically, varying the rate based on real-time air quality data is an ideal way to get it done. That's how to achieve significant energy savings and maintain a healthy building environment

Objectives Supported

- Build resilient low carbon systems
- Improve Building EUI
- Improve Safety

Principals Applied

- Balance carbon with cost
- Reach beyond our own assets
- Foster innovative solutions

Critical indoor parameters are monitored continuously to provide the data input needed to adjust ventilation rates for any given situation. On top of energy savings, the environmental health and safety team have access to Indoor Environmental Quality (IEQ) information to ensure safety and proper lab protocols are consistently being adhered to.



This can provide significant energy reduction with very attractive financial returns. This is recommended for further study during the next stage of project development.

b) Economics and Other Benefits

To be studied.

ECM ID	Electrical Savings						Thermal Savings			Saving Totals		Cost Est w/o TPC
	kW ^{DR}	kW ^{GA}	kW ^{Pk}	kWh	tCO2e	\$	MMBtu	tCO2e	\$	tCO2e	\$	
ES-ECM-07	0	0	0	0	0	\$0	0	0	\$0	0	\$0	\$0



c) Calculation Methodology

To be developed.

d) Constructability

To be developed.

ES-ECM-08: Investigate Building Heat Recovery

a) Overview

It is recommended to investigate additional building heat recovery. This can be from any source of heat such as:

- Exhaust Air
- Cooling Loads
- Environmental Chambers
- Steam Tunnels

This potential recovered heat could potentially be placed back into to offset building heating loads either passively or actively with use of heat pumps (preferred). This is recommended for further study.

Objectives Supported

- Build resilient low carbon systems
- Improve Building EUI

Principals Applied

- Balance carbon with cost
- Reach beyond our own assets
- Foster innovative solutions

b) Economics and Other Benefits

To be determined.

ECM ID	Electrical Savings						Thermal Savings			Saving Totals		Cost Est w/o TPC
	kW ^{DR}	kW ^{GA}	kW ^{PK}	kWh	tCO2e	\$	MMBtu	tCO2e	\$	tCO2e	\$	
ES-ECM-08	0	0	0	0	0	\$0	0	0	\$0	0	\$0	\$0

c) Calculation Methodology

To be provided.

d) Constructability

To be determined.



5.4 CCBR (DC)

The CCBR building is a 21,000 m², 13 floor laboratory building that was constructed in 2005. The building consists of a vivarium in the sub-basement (B1 level), a basement level loading dock, a multi-floor atrium in the front entrance, and research levels from floors 3 to 12. There are mechanical rooms located in the basement level, level 6, and on the penthouse (level 13). The research levels consist of a mixture of wet laboratory, support space, and administration, with 36 fume hoods currently operational (based on flow test reports). The building (and its AHUs) operates 24/7 year-round to support research activities. The building structure is flat slab concrete with an aluminum and glass cladding system. The building is ~90% glazed and has a double façade on the south side of the building.

5.4.1 Existing Conditions

Heating

The building is heated by two separate systems: a constant temperature heating (130/110°F) system for reheat coils located internally to the building, and a variable (scheduled) temperature heating system based on an outdoor temperature reset. High-pressure steam 200 psig from the District Network (DN) enters the building at the B1 level and rises to the 13th floor mechanical room and then reduced to low-pressure steam 10 psig. The low-pressure steam supplies two pairs of shell and tube heat exchangers. One pair of heat exchangers are dedicated to the constant temperature heating system and the other pair is for the perimeter heating system. A pair of base mounted pumps are dedicated to each system's heat exchangers. Water for the constant temperature system is distributed down the central core of the building and distributed to the reheat coils located on every floor. Water for the perimeter system is distributed down the perimeter of the building, serving groups of floor-mounted flat tube radiators on each level. The heat exchangers and pumps are sized for a duty/standby arrangement to allow for continuous operation during maintenance or failure of one exchanger and/or pump.

Domestic Hot Water

The domestic hot water system is supplied by three pairs of an instantaneous steam to hot water heaters. High-pressure steam from the District Network (DN) enters the building at the B1 level and rises to the 13th floor mechanical room and reduced to low-pressure steam. The low-pressure steam supplies one pair of heaters (HE-5 and HE-6) located in the 13th level mechanical room and two pairs of instantaneous hot water heaters (HE-1, HE-2, HE-3 and HE-4) located in the loading dock mechanical room. The instantaneous heaters located at the penthouse level supplies domestic hot water for floors 7 to 12. HE-1 and HE-2 supply domestic hot water to the DCM level. HE-3 and HE-4 supply domestic hot water to floor 1 to 6. The domestic heaters operate in a duty/standby configuration per system.

Ventilation

The building is segregated into five main areas for ventilation. The vivarium, the loading dock, the atrium, glass wash, and the lab floors. The air handling systems are as follows:

- The vivarium air is supplied by two 100% Outdoor Air (OA) air handling units (F-6 and F-7) that operate 24/7. The AHU has a N+1 fan configuration that allows for continuous operation during



maintenance or failure. The AHU contains a chilled water coil, glycol preheating coil and a steam face and bypass heating coil.

- The loading dock, atrium, and glass wash AHUs (F-3 and F-5) are recirculation type units with a supply and return fan. The AHUs each contain a chilled water coil, glycol preheating coil and a steam face and bypass heating coil. Refrigerators were installed in the glass wash area requiring cooling even during periods when the glass wash space is not in operation.
- The laboratory levels are split into four different zones and are typical from floors 3 to 5 and 7 to 13. The floors are separated into four ventilation zones (refer to Figure 20): south offices, north lab, south lab, and the support space.

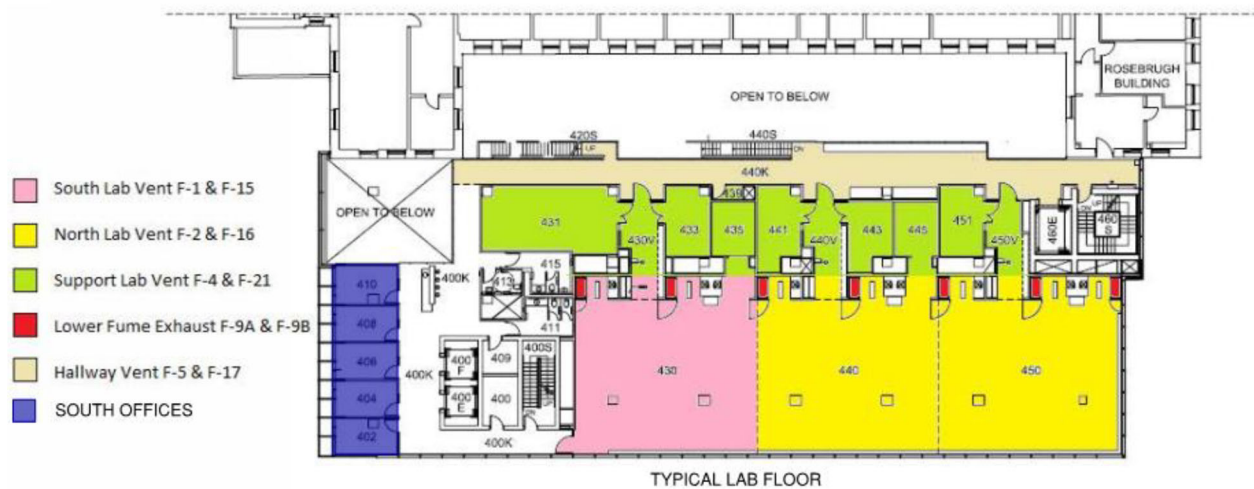

Figure 20: Typical Lab Floor Layout



5.4.2 Energy Conservation Measures (ECMs)

The following ECMs are proposed for further analysis at CCBR.

DC-ECM-01: Lighting Upgrade

a) Overview

The CCBR building is due for a lighting modernization. We propose that the building lighting system be modernized to LED lights. A good portion of the scope is converting T8-28-Watt fluorescent bulbs to 15W LED equivalence. There are opportunities to also retrofit with even lower wattage replacement bulbs and to also strategically deploy occupancy sensors to augment the savings potential.

Objectives Supported

- Build resilient low carbon systems
- Renew existing and aged utility infrastructure
- Improve life safety

Principals Applied

- Balance carbon with cost
- Reach beyond our own assets
- Foster innovative solutions

b) Economics and Other Benefits

We have only included utility savings and have also taken into consideration both the cooling effect reduction and added heating load. We have not included any operational savings but do expect a reduction in operating costs due the longer life LEDs.

ECM ID	Electrical Savings						Thermal Savings			Saving Totals		Cost Est w/o TPC
	kW ^{DR}	kW ^{GA}	kW ^{PK}	kWh	tCO2e	\$	MMBtu	tCO2e	\$	tCO2e	\$	
DC-ECM-01	0	90	90	781,320	23	\$67,948	-2,353	-123	-\$19,407	-100	\$48,541	\$271,606

c) Calculation Methodology

Within the CCBR Lighting Audit spreadsheet, U of T estimated the whole building's existing lighting power density (LPD) by extrapolating the 8th floor lighting wattage and 8th floor area. The same approach was used to estimate the whole building LPD with LED lamps replaced. The LED lamps are expected to reduce the LPD by 44%. This percentage reduction was then applied to the baseline energy model LPD.

d) Constructability

We have assumed the installation work will be done during regular working hours or during low occupancy periods. We are proposing to install this measure in many areas of the facility including in academic areas so that requires careful coordination. We will create a detailed communication and delivery plan due to the nature of this installation, before work commences.



DC-ECM-02: Adiabatic Humidification (To be Vetted)

a) Overview

When converting from steam to low temperature hot water heating systems it is also worth considering converting steam-based humidification systems to low temperature compatible humidification systems.

An adiabatic system is one such option to consider over the steam-based system currently in operation. This type of system creates small particles of water in the air stream that absorb heat energy from the air to evaporate the water and raise the relative humidity. This means that heat energy which has been created efficiently by a heat pump with its high COP is now being used to evaporate the water and create the required humidity levels, rather than using energy from the central steam plant being delivered to the air handler at relatively low efficiencies.

However, given this is not yet been proven to the operating staff at U of T, we are recommending a pilot installation be performed in a less critical building. Should this prove successful we would proceed moving with further installations.

The following table from Arup's report describes the existing requirements for the steam humidifiers located inside the AHUs:

Objectives Supported

- *Build resilient low carbon systems*
- *Renew existing and aged utility infrastructure*
- *Improve safety and building comfort*

Principals Applied

- *Balance carbon with cost*
- *Reach beyond our own assets*
- *Foster innovative solutions*



Table 10: Preliminary Air Handler Humidification Load

AHU	Location	Capacity kg/hr (lbs/hr)
F-1	Level 6	346 (761)
F-2	Level 6	505 (1,111)
F-3	Level 13	226 (497)
F-4	Level 13	266 (585)
F-5	Level 13	226 (497)
F-6/7	Loading Dock	532 (1,170)
F-28	Level 6	33 (73)

Note that in Arup’s report, a 1,625kW electric boiler was recommended. If heat pump is used, the electrical demand will be significantly reduced through heat pumps. This serves to further lower the building EUI and create additional energy savings but does require U of T’s acceptance of pilot.

To meet ASHRAE standard 170 requirements in the prevention of legionellae when using the adiabatic systems in health care or laboratory environments, only the spray mist systems are acceptable. From ASHRAE Standard 170:

6.6.3 Adiabatic Atomizing Humidifier Requirements

Humidifier water shall be treated with a reverse osmosis process, a UV-C sterilization light source, and a submicron filter. Informative Note: Treated humidifier water shall be continuously circulated from the source to the humidifier valves. All valves, headers, and piping not part of the recirculation loop shall drain completely when not in use. Water temperature shall be maintained within the control limits in the legionellosis risk management plan. (Informative Note: For more information, reference ASHRAE Guideline 12 and ASHRAE Standard 188.)

Ports suitable for testing water quality shall be provided in the treated humidifier water piping system. Moisture eliminators shall be provided as required to prevent moisture accumulation in ductwork. Water



purity shall meet or exceed potable water standards at the point where it enters the ventilation system, space, or water-vapor generator.

The proposed humidification system consists of R.O. water purification, pump station, Storage tank w/ UVC lamp, pump, high pressure water spray system.

b) Economics and Other Benefits

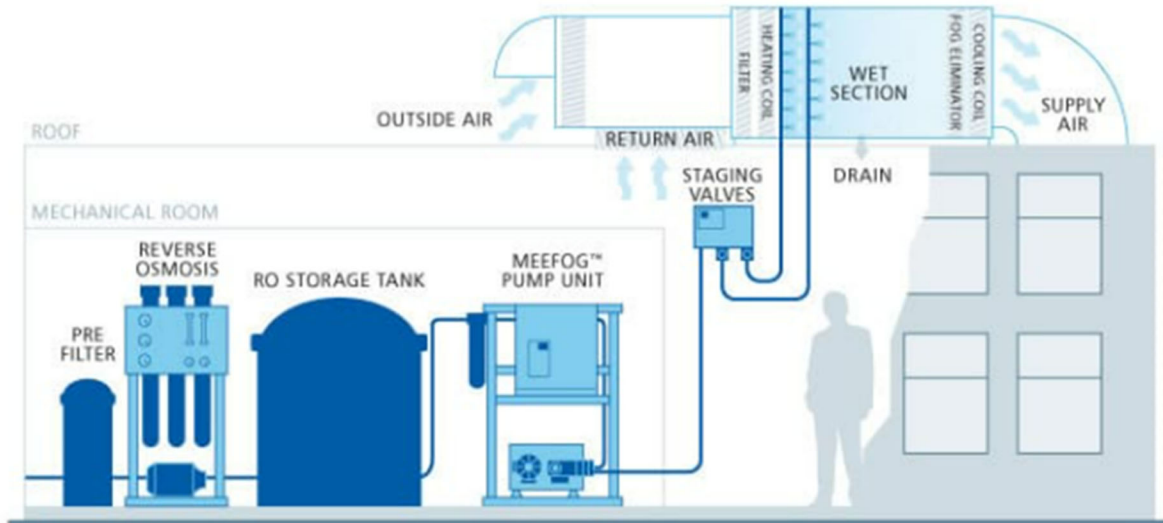

Figure 21: Typical Adiabatic Schematic

This ECM is to be vetted but we have carried utility savings and not added operational requirements for the added water treatment systems as a place holder. The maintenance cost will be finalized during the vetting process of a pilot.

ECM ID	Electrical Savings						Thermal Savings			Saving Totals		Cost Est w/o TPC
	kW ^{DR}	kW ^{GA}	kW ^{PK}	kWh	tCO ₂ e	\$	MMBtu	tCO ₂ e	\$	tCO ₂ e	\$	
DC-ECM-02	0	0	0	-863,264	-26	-\$20,118	8,839	463	\$72,904	437	\$52,787	\$300,772

c) Calculation Methodology

We have calculated the savings based on the modelled fan humidity usage and utilized the heat pump for heating with a very conservative efficiency of COP of 3. This aligns well with billing data.

d) Constructability

This type of humidification system does require more space for absorption of humidity as compared to conventional steam type system. Constructability issues with respect to reconstruction of air handlers for adequate absorption dimensions are anticipated in at least some instances. While there are many examples of functional operating systems in critical environments, due diligence is required as to not



cause detrimental effects also observed. We are recommending that a pilot installation be considered and built into the process in a less critical building prior to moving ahead with this ECM.

DC-ECM-03: LTHW Conversion

a) Overview

This measure is part of the campus wide LTHW project and the building heating systems will be connected with CCBR building's future LTHW loop. For CCBR, the prerequisite is separated into 4 parts where the district steam is used for space and domestic hot water heating:

- ECM 3a: Provide low-temperature water (LTS/LTR) from the District Network (DN) to the existing constant temperature heating system. Peak heating load converted from steam to the low-temperature water is approximately 2,755kW (9,400kBtuh).
- ECM 3b: Provide LTS/LTR piping from the DN to the existing perimeter heating system. Peak heating load converted from steam to the low temperature water is approximately 293kW (1,000kBtuh).
- ECM 3c: Provide LTS/LTR piping from the DN to the existing AHU heating system. Peak heating load converted from steam to the low temperature water system is approximately 3,200kW (10,918kBtuh).
- ECM 3d: Provide LTS/LTR water for the domestic hot water system.

Objectives Supported

- Build resilient low carbon systems
- Renew existing and aged utility infrastructure

Principals Applied

- Balance carbon with cost
- Reach beyond our own assets
- Foster innovative solutions

The updated feasibility study report by Arup serves the basis of this measure. Reference to Arup's report section 3, ECM0.

b) Economics and Other Benefits

We have not included any utility reduction benefit at this stage. This ECM is designed around future opportunities to utilize either Nodal LTWH or additional EAHR. We have not assessed the operational differences at this stage but do not expect any changes from current requirements.

ECM ID	Electrical Savings						Thermal Savings			Saving Totals		Cost Est w/o TPC
	kW ^{DR}	kW ^{GA}	kW ^{PK}	kWh	tCO2e	\$	MMBtu	tCO2e	\$	tCO2e	\$	
DC-ECM-03	0	0	0	0	0	\$0	0	0	\$0	0	\$0	\$9,198,160

c) Calculation Methodology

We have not included any utility reduction benefit at this stage.



d) Constructability

Arup has provided a schematic design with siting and required piping and electrically design for this ECM. This design forms the basis of the costing submitted to the costing consulting. We propose to install this measure in many areas of the facility including in academic areas so that requires careful coordination. We will create a detailed communication and delivery plan due to the nature of this installation, before work commences.

DC-ECM-04: General VAV/DCV & Pump VFDs

a) Overview

It's recommended to provide new variable frequency drives for the chilled water, constant temperature heating, and the scheduled heating system pumps. Pump motors will need to be replaced to allow for modulation.

Demand control ventilation can also be incorporated by using CO2 and occupancy sensors in the general spaces such as conference and meeting rooms.

b) Economics and Other Benefits

We have only included utility savings and no added operational costs at this stage. We do recognize there will be added sensor calibration requirements.

Objectives Supported

- Build resilient low carbon systems
- Renew existing and aged utility infrastructure
- Improve building comfort

Principals Applied

- Balance carbon with cost
- Reach beyond our own assets
- Foster innovative solutions

ECM ID	Electrical Savings						Thermal Savings			Saving Totals		Cost Est w/o TPC
	kW ^{DR}	kW ^{GA}	kW ^{Pk}	kWh	tCO2e	\$	MMBtu	tCO2e	\$	tCO2e	\$	
DC-ECM-04	0	0	0	487,900	15	\$11,370	4,295	225	\$35,426	240	\$46,796	\$576,024

c) Calculation Methodology

Arup's modelled savings have been included and balanced to utility data. See Arup's Report for more details.

d) Constructability

No issues have been identified at this stage of development.



DC-ECM-05: Heat Recovery Chiller

a) Overview

Basis of design every heat pump requires both a heat source as well as a heat sink. An exhaust air heat pump utilizes the exhaust air from a buildings ventilation system has a constant heat source at a temperature of approximately 72°F to 74°F. A cooling coil is placed in the exhaust airstream to cool the exhaust air down to close to 32°F, in doing so energy from the exhaust airstream is transferred to the evaporator circuit of the heat pump and is leveraged as a heat source to create higher grade heat on the condenser circuit. The condenser circuit is connected to the heating coils for the air handling units and surplus heat is sent to perimeter and domestic hot water heating systems.

Objectives Supported

- *Build resilient low carbon systems*
- *Improve building EUI*

Principals Applied

- *Balance carbon with cost*
- *Reach beyond our own assets*
- *Foster innovative solutions*

In a laboratory environment, exhaust air heat recovery can typically recover enough heating energy to offset approximately 40% of the total building heating needs. Additional heat recovery chiller opportunities exist when there are simultaneous heating and cooling. The heat recovery chiller will provide the buildings base load requirements for chilled water needs throughout the winter months while providing an equivalent of 1.25 times as much heating energy to supply the perimeter heating requirements. We have applied the COP of three for cooling and five for heating. The CCBR building has an existing run around heat recovery loop. Reference Arup's report page 4 and page 22, those run around loop is between F-1, F-2, and F-8A/B, F9-A/B. The total exhaust air flow rate is 96,000CFM. The heat recovery coils that have been removed from the run around system would be reinstalled, the exhaust fan would also be resized modified, or replaced, to provide the proper airflows. The glycol heat recovery loop would be modified to place a heat pump between the heating portions of the runaround loop and the cooling portions (heat source) of the runaround loop thus leveraging the refrigeration cycle to provide greater efficiency. This has the additional benefit of providing higher grade heat to preheat class 4 laboratory systems requiring 100% fresh air. The high COP of the heat pump as well as the higher-grade heat both provide distinct advantages over a run around loop style system, where the run around typically has an overall seasonal efficiency of 40% the heat pump heat recovery modification should yield an overall efficiency exceeding 130%, three times more than the runaround system.

In the same manner, we also suggest that using heating recovery chiller on the vivarium system. The two air-handling units have a total air flowrate of 120,000CFM. The sizes of the proposed HR chillers will be 363-ton, and 455-ton for the lab system and the vivarium system, respectively. Note that the proposed measure here is different from the Arup's 150-ton HR chiller measure (Arup's report, page 39-40)



The location of HR chiller for vivarium system is on loading dock where Arup's 150-Ton chiller location is proposed (see Figures 38-39 on page 40 of Arup report). The location of HR chiller for lab system is on roof penthouse where Arup proposed electric boiler will be installed. Since this report will not recommend electrical boilers, the space will be freed up for a HR chiller running for lab system exhaust air heat recovery (See page 41 of Arup report).

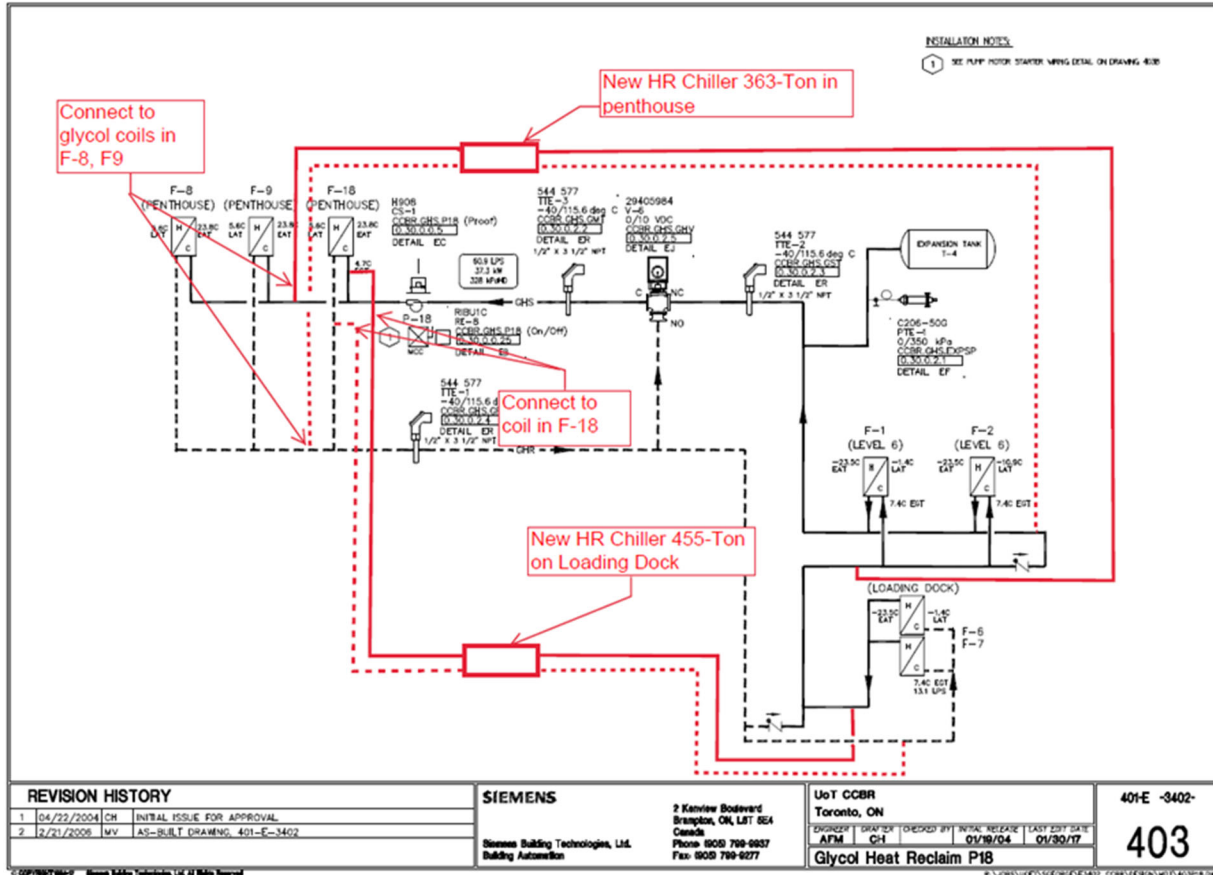

Figure 22: Proposed Heat Recovery Layout

b) Economics and Other Benefits

We have only included utility savings and no added operational costs at this stage for the added equipment such as pumps, controls, chiller, etc., We will investigate and determine the additional differential operation costs of this ECM during the detailed engineering phase.

ECM ID	Electrical Savings					Thermal Savings			Saving Totals		Cost Est w/o TPC	
	kW ^{DR}	kW ^{GA}	kW ^{PK}	kWh	tCO _{2e}	\$	MMBtu	tCO _{2e}	\$	tCO _{2e}		
DC-ECM-05	0	0	-911	-3,073,497	-92	-\$204,191	31,469	1,649	\$259,563	1,557	\$55,372	\$4,848,812



c) Calculation Methodology

We have modelled the savings on maximum heat recovery availability from exhaust air and balanced utility data. See Energy Balance for calculation.

d) Constructability

Arup has provided a schematic design with siting and required structural and electrically design for this ECM. This design forms the basis of the costing submitted to the costing consulting.

DC-ECM-06: Upgrade BAS and Commission

a) Overview

At CCBR we propose that the BAS be upgraded and centrally connected to EBI. We are recommend including optimization with energy efficient sequences and recommissioning. These include an upgrade to the building automation system as well as attention to building operation including building pressurization an operation of the active building envelope on the South façade. It is recommended to implement ongoing Cx on lab ventilation systems for system tune-ups and appropriate adjustment of ventilation rates to meet codes and regulations requirements, as well as demand control ventilation opportunities. Additional items may be looked at such as pressure resets on the domestic water system, installing variable frequency drives on equipment and demand control ventilation.

Objectives Supported

- Build resilient low carbon systems
- Renew existing and aged utility infrastructure
- Improve comfort conditions

Principals Applied

- Balance carbon with cost
- Reach beyond our own assets
- Foster innovative solutions

b) Economics and Other Benefits

We have only included utility savings and no operational savings at this stage.

ECM ID	Electrical Savings					Thermal Savings			Saving Totals		Cost Est w/o TPC	
	kW ^{DR}	kW ^{GA}	kW ^{PK}	kWh	tCO ₂ e	\$	MMBtu	tCO ₂ e	\$	tCO ₂ e		\$
DC-ECM-06	0	0	0	844,361	25	\$19,677	8,011	420	\$66,079	445	\$85,756	\$1,093,717

c) Calculation Methodology

We have calculated savings based on a conservative 15% reduction of the HVAC loads as per energy balance.



d) Constructability

Costing is based on previous BAS retrofits at the university. We propose installing this measure in many areas of the facility including in academic areas so that requires careful coordination. We will create a detailed communication and delivery plan due to the nature of this installation, before work commences.

DC-ECM-07: Battery Energy Storage System (BESS)

a) Overview

To further enable demand response and GA avoidance 3.3MWh hours of battery storage will be installed in the central heating plant. The batteries will be purchased in a self-contained unit and installed in a stacked manner near the electrical infrastructure. The 3.3MWh of capacity will provide 1.1MW of demand response capacity.

There are multiple benefits to the battery storage systems as they can be charged overnight when electricity is both cheap and clean with a lower carbon content than the marginal during daytime operation. The conversion efficiency of the batteries is also very high at over 90%. Containerized solutions provide an advantage for noise mitigation and the ability to relocate generator in future to accommodate relocation of the Central Plant and/or Nodal Plant Design.

Objectives Supported

- Build resilient low carbon systems

Principals Applied

- Balance carbon with cost
- Reach beyond our own assets
- Foster innovative solutions

Scope of Work:

Supply a containerized BESS solution 1.1MW @ 3 hours (3.3MWh) batteries with required HVAC, controls, etc.

b) Economics and Other Benefits

The savings are focused solely on demand management and displacing GA peak events. We have not yet included the operational costs required to maintain the BESS but do expect to include them at the next stage of detailed design.

ECM ID	Electrical Savings						Thermal Savings			Saving Totals		Cost Est w/o TPC
	kW ^{DR}	kW ^{GA}	kW ^{PK}	kWh	tCO2e	\$	MMBtu	tCO2e	\$	tCO2e	\$	
DC-ECM-07	825	968	0	0	0	\$435,222	0	0	\$0	0	\$435,222	\$3,016,836

c) Calculation Methodology

Calculation is based on displacing 3.5 out of the 5 GA peaks.



d) Constructability

The equipment siting has not been finalized. We have assumed a “typical” installation with proximity to an electrical connection with no added structural work or the like. Since these are based on containerized solutions, they can be relocated to suit best siting location for optimized costs.

DC-ECM-08: Investigate Lab VAV/DCV

a) Overview

The very nature of work being conducted in research facilities requires proper ventilation to be maintained to ensure a safe environment for all occupants. And the energy consumption of labs must be taken into consideration when planning energy efficiency initiatives.

Maintaining 100% fresh air ventilation in a life science facility translates into large amounts of energy being consumed. There is an opportunity to introduce Demand Control Ventilation in the Labs, by implementing a Lab Demand Control Ventilation (DCV) system. Basically, varying the rate based on real-time air quality data is an ideal way to get it done. That’s how to achieve significant energy savings and maintain a healthy building environment

Objectives Supported

- Build resilient low carbon systems
- Improve worker safety

Principals Applied

- Balance carbon with cost
- Reach beyond our own assets
- Foster innovative solutions

Critical indoor parameters are monitored continuously to provide the data input needed to adjust ventilation rates for any given situation. On top of energy savings, the environmental health and safety team have access to Indoor Environmental Quality (IEQ) information to ensure safety and proper lab protocols are consistently being adhered to.



This can provide significant energy reduction with very attractive financial returns. This is recommended for further study during the next stage of project development.

b) Economics and Other Benefits

To be studied.

ECM ID	Electrical Savings						Thermal Savings			Saving Totals		Cost Est w/o TPC
	kW ^{DR}	kW ^{GA}	kW ^{Pk}	kWh	tCO2e	\$	MMBtu	tCO2e	\$	tCO2e	\$	
DC-ECM-08	0	0	0	0	0	\$0	0	0	\$0	0	\$0	\$0



c) Calculation Methodology

To be developed.

d) Constructability

To be developed.



5.5 McCaul (MC)

We have combined the following buildings under this group: 1) Health Sciences (HA), 2) Exam Centre and (EX), and 3) Old Administration Building (OA).

Health Sciences (HA) (154)

The Health Sciences Building dates from 1957 and has seven above grade stories plus a basement and a rooftop penthouse plant space. It has a mix of uses including administrative offices, classrooms, teaching labs, basement parking along with auditoriums on the first and sixth floors. It has two bridges, on the second and third floors, which link it to adjacent buildings: EX (255 McCaul Street) and OA (263 McCaul Street).

Exam Centre (EX) (155)

The Exam Centre Building dates from 1917 as industrial warehouse has four floors plus a partial basement space. After 2008 major renovation, U of T has repurposed the building function as a mix of uses including exam center on first to third floors, and administrative offices for facilities and services on fourth floor. It has two bridges, on the second and fourth floors, which link it to adjacent buildings: HA (155 College Street) and OA (263 McCaul Street).

Old Administration Building (OA) (156)

The Administration Building (building 156 – Health and Wellbeing of the University of Toronto is located at 263 McCaul Street. The rectangular shaped building was built in 1915 and was occupied by the Toronto Board of Education. The University acquired the building in 2003 and is now occupied by the University Department of Family and Community Medicine on the third and fourth floors, the Health and Well Being department on the 2nd floor and the Toronto School Board Sesquicentennial Museum and Archive on the first floor. The four-story building has a basement, and a total area is 3029 m². The building is connected to the adjacent buildings 154 and 155 by glass enclosed steel framed elevated walkways.

5.5.1 Existing Conditions

Heating

Steam from Enwave enters the utility tunnel that joins OA and EX about in the middle below the outdoor parking. Steam enters at 200PSI in the utility tunnel and then continues travelling in the utility tunnel and enters EX and reduces to 100PSI and then again to 14PSI to feed existing boiler steam header in the EX Boiler Room. The steam header was originally fed from the disconnected old steam boilers left in place with all insulation removed. The steam header continues to feed:

- One feed from steam travels back via the utility tunnel to OA and converts to South & North HX's in basement and then continues with a steam line up to OA Penthouse MR to feed AHU steam coils. Same line feed steam unit heaters in bridge joining OA & EX. In addition, the steam also feeds DHW HX and is converted via 2 tanks.



- Two domestic hot water tanks located in basement heated by steam coils in tanks. Top tank (LP) supplies DHW up to the 4th floor and the bottom tank (HP) supplies from the 5th to the top floor.
- Another line travels in utility tunnel to OA basement and converts to hot water perimeter and hot to AHU plus convertor for small bridge 154 & 156
- Another steam line (2 lines for redundancy) travels to EX in basement mechanical room to 2 HXs one for perimeter and the other for AHUs. The hot water from the basement mechanical rooms HXs travel to the perimeter radiators and the air handlers on the roof
- There are 2 indoor parking garages in OA that have steam unit heaters
- There is one AHU in EX basement MR that is has steam coils

Gas DHW & Plumbing

Three gas fired domestic hot water heaters provide domestic hot water (DHW) for the buildings EX and OA. The DHW heaters are in the boiler room. Washroom facilities are located on each of the three floors and in the basement. A grey water system consists of rainwater cistern tanks, pumps in basement, and an expansion tank. The system was designed for saving portable water by using collected rainwater for flushing plumbing fixtures.

Chilled Water Systems

There is one air cooled glycol chiller on the roof of EX that supplies cooling to EX Air Handlers and there is another chiller in EX Basement with corresponding cooling tower on EX roof that feeds HA and OA. They are separate systems. For HA the primary chilled water is used in AHUs and then perimeter/Induction unit in summer. Chiller and chilled water pumps are in EX. Chilled water pumps are variable speed. Cooling coils has 3-way valves at AHUs. Chilled water operating temperature set between 44 to 48°F depending on OAT. Chiller can be OFF on schedule or based on low OAT. Most if not all AHUs in EX have VFD on supply and return fans.

HA Ventilation & BAS

The building had a major renovation in the early 2000s that included installation of several new AHUs in the rooftop penthouse along with a LED lighting retrofit in 2019. The building recently has completed a roof replacement project and does not have PV panels installed. Except for the steam system, the PRV is on a pneumatic control system. The building automation systems are on DDC controls that date from the time of the major renovation over 15-years ago.

Heating, cooling and ventilation are provided to the spaces via perimeter induction units that are original to the building and separated in a North-South configuration with regards to the AHUs that supply them (AHU 01 and AHU 02, respectively). The induction units have local wall- mounted thermostats that control space temperature via modulating control valve. Control via the local coil water temperature and the water circuits are switched seasonally between heating hot water and cooling chilled water. By Central switch over, not at the unit. CCMS control panel located in basement mechanical room has a summer and winter mode to switch over. Heating water and chilled water switch over valves located in basement mechanical room #091.



AHUs 03 & 04 serves most building spaces on floors 1-7, supplementing the induction systems. AHUs 05 & 06 serves the first and sixth floor auditoriums, respectively. AHU 08 serves the basement and the lobby is served by a fan coil unit in the basement for winter heating. A relatively small, newly installed, AHU serves a classroom space on the 7th floor and includes an air-to-air plate heat exchanger. All the AHUs, except for AHU 08, are in the penthouse plant room which acts as an air return plenum and incorporates exhaust and OA dampers as part of the envelope. AHUs 01 to 06 are on CCMS schedule fan shut- down during unoccupied time. Interior rooms have VAV Boxes (AHU 3 to 6). No reheat coils. Interior rooms have VAV boxes, no induction units.

All AHUs (1 to 6) located in PH Mechanical room at 8th floor. Return air from all the room from building supplying air to mechanical room (return air plenum) through return air Fans (RF1 and RF2). Return air fans supplying air to all AHUs through mixing damper and exhaust through exhaust air damper. RF1 and RF2 have VFD.

- AHU-1,2: supplying air to induction units at north and south
- AHU-3,4: supplying air to east and west side of building through VAV
- AHU-5: supplying air to 1st floor Room 106 and 108 (west of building)
- AHU-6: supplying air to auditorium at level 6, room 610.
- One air compressor located in PH mech room which is used for labs only

One HRV unit located in PH mechanical room which heat the fresh air with exhaust air and supplying to two classrooms on 7th floor.

- AHU-1: South Induction – SP 64.4°F
- AHU-2: North Induction – SP 64.4°F
- AHU-3: West Interior – SP 64.4°F
- AHU-4: East Interior – SP 63.5°F
- AHU-5: Auditorium 1st floor– SP 63.5°F
- AHU-6: Auditorium 6th floor–SP 63.5°F

HA Third Floor Server Room

A third-floor data server room (room no.309) has two air-cooled Liebert units with the condenser located at EX Roof.

EX AHU's & Ventilation

The five air-handling units and one air-cooled chiller are also installed on the roof. The boiler room located in basement and occupied two floor space, and a 500-ton chiller in the chiller room on ground floor serves the other buildings.



The main condensate return system is in the basement boiler room and consists of a condensate collection tank and two condensate pumps. Two heating exchangers (HE-1&HE-2) using steam as primary heating source to feed the hot water heating system and glycol heating system.

Chilled water pumps, and glycol heating pumps are equipped with VFDs, and the hot water pumps are running at constant speed.

The five AHUs are equipped with glycol heating coils, and cooling coils.

- AHU-1 serves level-1 basement space and provides cooling and ventilation.
- AHU-2 serves level-2 exam room RM200 and provides cooling and ventilation.
- AHU3 serves the lobby area and provides cooling and ventilation.
- AHU-4 serves the third-floor exam rooms and provides cooling and ventilation.
- AHU-4 serves the fourth floor F&S office and provides cooling and ventilation.

OA AHU's & Ventilation & BAS

- Basement AHU has steam heating and DX for cooling which feeds 25% of 1st floor rooms.
- Two air compressors are in basement. One in service and one on STBY. Air compressor used for pneumatic control for AHUs.
- Small steam to glycol HE located in basement, used for heating radiators at the bridge to Building 154 through heating glycol circulation.
- This building has local control only. No CCMS, EMRS, and BAS.
- Two DCW booster pumps located in basement mech room have VFDs.
- AHU-2 at 2nd floor mech room:213 and AHU-3 at 3rd floor room 317.
- AHU-2 &3 have heating water from basement HE and 3-way valve at AHUs
- AHU-2,3 have chilled water from exam center and 3-way valve at AHUs.
- All AHUs have no VFDs for supply and Return Fans.
- Basement AHU-1: for some rooms (25%) at 1st floor
- 2nd floor AHU-2: For 2nd floor and partially 1st floor.
- 3rd floor AHU-3: For 3rd, 4th, 5th floors.
- No humidification in AHUs. No VAVs, and no reheat.
- All the rooms have hot water radiators. T-Stat controls radiator's heating output.



EX Electrical

Electrical Main Service

The building is supplied with a 2500A, 120/208V, 3 phase, 4 wire service from Toronto Hydro. The incoming service conductors enter from the Toronto Hydro vault and feeds the main switchboard. The incoming service conductors are housed in a protective enclosure.

Electrical Distribution

There are Toronto hydro meters, located within the main electrical room, for the Supply building and the Old Administration building.

Emergency Power

There is an existing Cummins, 225kW, 120/208V standby generator for the building.

Solar PV on Roof

There has been 67 kWac solar panels installed on the roof. Annual electricity generation is approximately 73,000 kWh tied into the building hydro meter.

Lighting

Throughout the building the lighting fixtures comprise of PL/CFL pot lights, under cabinet LED task lights, T5 fluorescent one or two-lamp fixtures. Some of T5 fixtures in stairwells recently have been converted to LED. Main lighting control is by Douglas control system dated back to 2008 major renovation.



5.5.2 Energy Conservation Measures (ECMs)

The following ECMs are proposed for further analysis at McCaul.

MC-ECM-01: Upgrade Lighting in EX & OA

a) Overview

This measure proposes that lighting be updated to more efficient in EX & OA.

EX Lighting

Throughout the building the lighting fixtures comprise of PL/CFL pot lights, under cabinet LED task lights, T5 fluorescent one or two-lamp fixtures. Some of T5 fixtures in stairwells recently have been converted to LED. Main lighting control is by Douglas control system dated back to 2008 major renovation.

Most of the lighting type in the building has not been converted to LED yet. This measure recommends all existing fluorescent based and compact fluorescent based T5 lamps and pot lighting to be replaced with LED equivalent.

OA Lighting

Most of the lighting type in the building has not been converted to LED yet. This measure recommends all existing fluorescent based and compact fluorescent based T8 lamps and pot lighting to be replaced with LED equivalent

Objectives Supported

- Build resilient low carbon systems
- Renew existing and aged utility infrastructure
- Improve comfort conditions and life safety

Principals Applied

- Balance carbon with cost
- Reach beyond our own assets

b) Economics and Other Benefits

We have only included utility savings and have also taken into consideration both the cooling effect reduction and added heating load. We have not included any operational savings but do expect an operational cost reduction due to longer life LEDs.

ECM ID	Electrical Savings						Thermal Savings			Saving Totals		Cost Est w/o TPC
	kW ^{DR}	kW ^{GA}	kW ^{PK}	kWh	tCO2e	\$	MMBtu	tCO2e	\$	tCO2e	\$	
MC-ECM-01	0	24	24	121,090	4	\$6,345	-146	-11	-\$3,165	-7	\$3,179	\$94,789

c) Calculation Methodology

We have estimate LPD. The LED lamps are expected to reduce the LPD by 44%. This percentage reduction was then applied to the baseline energy model LPD.



d) Constructability

We have assumed the installation work will be done during regular working hours or during low occupancy periods. We propose to install this measure in many areas of the facility including in academic areas so that requires careful coordination. We will create a detailed communication and delivery plan due to the nature of this installation, before work commences.

MC-ECM-02: McCaul Electrification

a) Overview

As part of the mandatory requirements the U of T does not intend to renew the Enwave steam contract which will end in November 2027. This ECM proposes the electrification of the grouped McCaul buildings EX, OA, and HA prior to the expiration of the Enwave contract.

At a high level conceptually, this involves disconnecting steam from Enwave and using Ground Source Heat pumps with exhaust air heat recovery from AHUs with electric boilers for peak heating (> 140°F). In addition, to centralize cooling for the proposed heat pump to use heat to recharge ground loop in summer. We also propose to convert the dedicated natural gas DHW to electric.

Objectives Supported

- *Build resilient low carbon systems*
- *Renew existing and aged utility infrastructure*
- *Reduce building EUI*

Principals Applied

- *Balance carbon with cost*
- *Reach beyond our own assets*
- *Foster innovative solutions*

Scope of Work

- Install new Heat Pump 400-Ton @ 160F output in chiller room with 150-Ton geo exchange field in parking lot and garage
- Remove steam boilers in EX boiler room and install 1100kW electric boiler
- Supply hot water from boiler to:
 - To basement MR in OA to replace 2 x HX's (North and South Loops)
 - To PH MR in OA and in OA PH MR remove steam coils and install hot water coils 130°F



- Replace bridge steam heating unit with hot water fed from riser from EX to HA PH MR
- To 2 x HXs in basement EX MR
- To 3 x HX's in OA basement MR and replace 1 A HU steam coil located on basement with hot water
- To 2 x parking garage steam U/H's and replace with hot water
- To HA AHU's steam coils
- Connect the EX PH air cooled chiller to basement chiller in EX
- Install new elect 80 kW DHW and tanks in EX Boiler Room and replace 3 x gas fired DHW in same room
- Install exhaust air coils in AHU's in HA & EX PH and Roof Air handlers
- Connect exhaust coils in 155 & 154 to chiller room located in 155 basement with new heat pump chiller

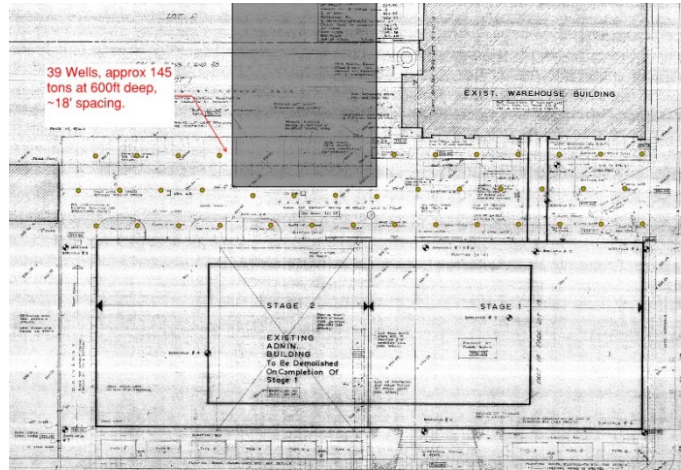

Figure 23: Proposed Location for Geo Field

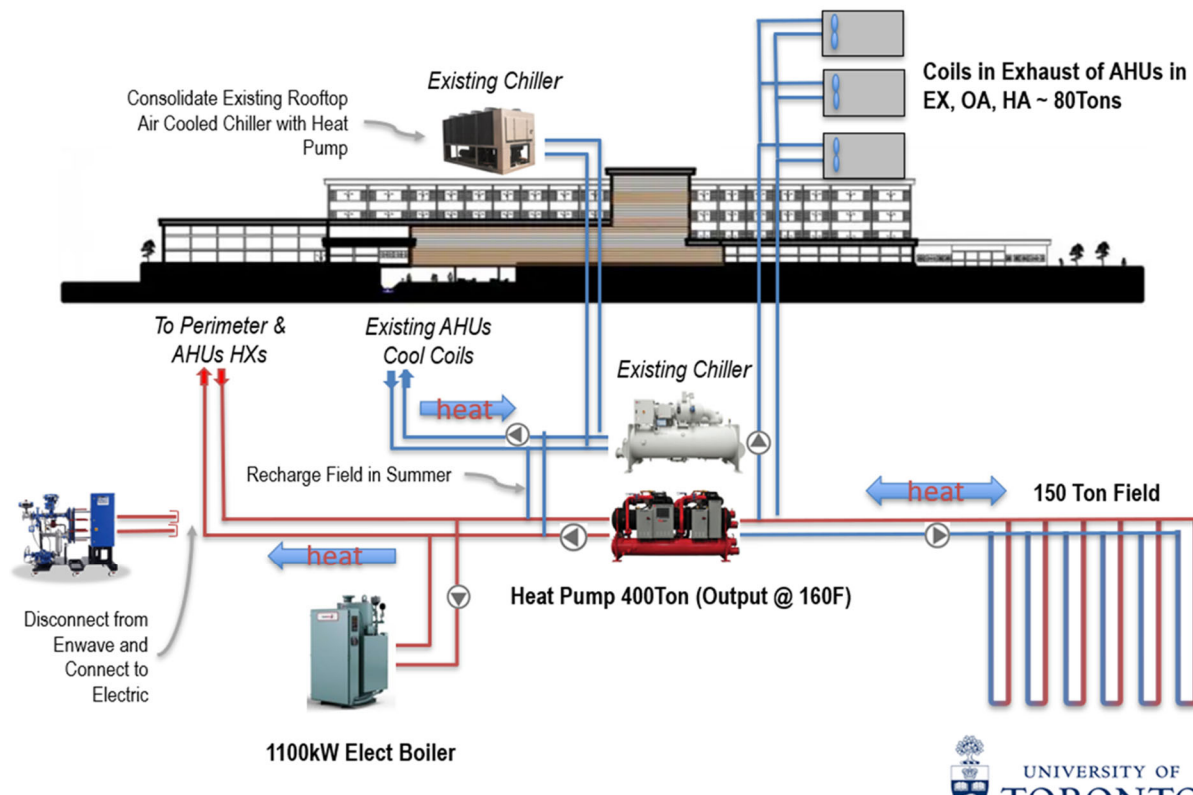

Figure 24: Proposed GSHP Schematic



- Install adiabatic or electric humidification in AHU's

Nodal Plant Option

The McCaul cluster is part of the new Master Plan Nodal system design and referred to as Node 8. The U of T is considering connecting the McCaul Node 8, to the Nodal System, referred to as Node 5, both electrically and thermally, currently under conceptual design by WSP at the writing of this report. This will need to be considered and analyzed at the next stage of detailed design for what's the best solution for U of T long-term.

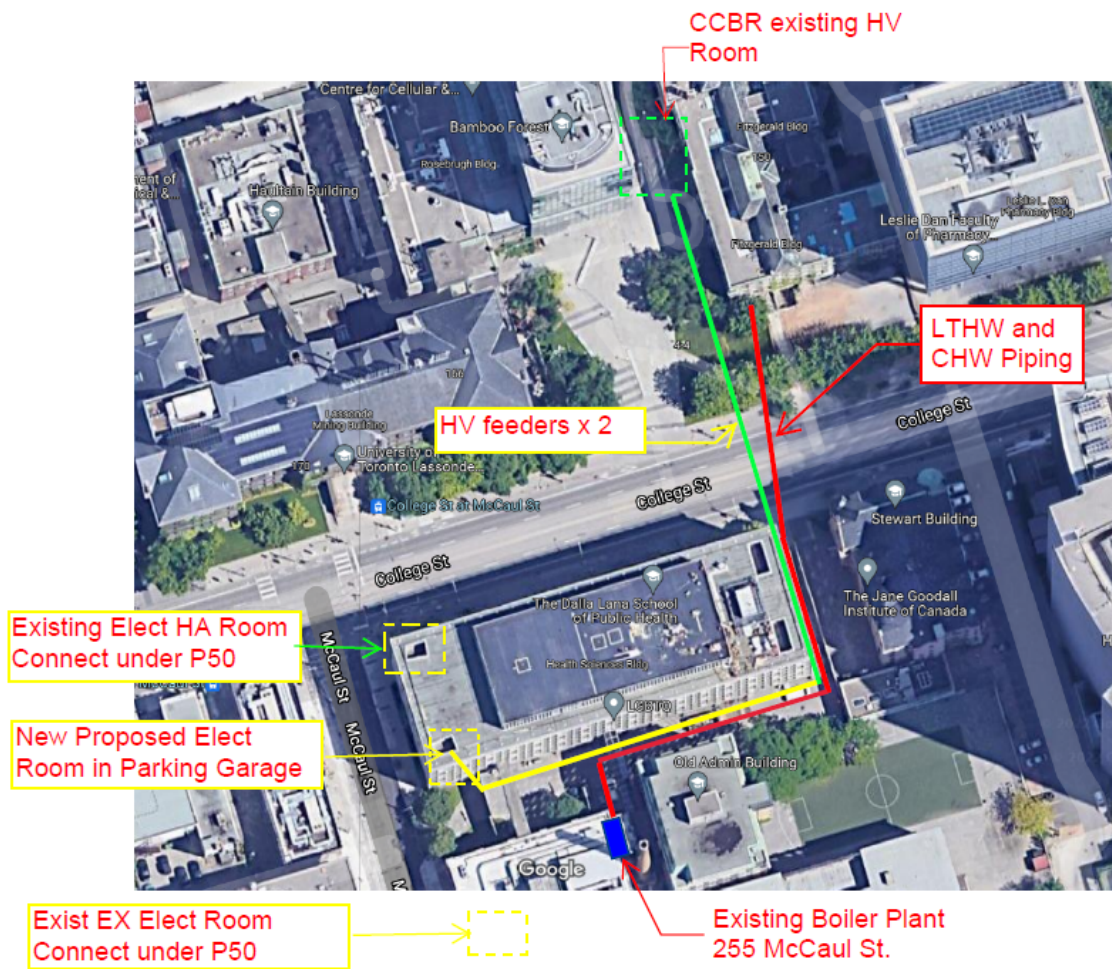

Figure 25: Nodal Integration Option



b) Economics and Other Benefits

We have only included utility savings and not added operational costs for the added equipment. We do expect added costs for the new equipment but on differential basis as the U of T has existing chillers for example but will have added equipment such as BAS, pumps, boilers, etc.,

ECM ID	Electrical Savings						Thermal Savings			Saving Totals		Cost Est w/o TPC
	kW ^{DR}	kW ^{GA}	kW ^{PK}	kWh	tCO2e	\$	MMBtu	tCO2e	\$	tCO2e	\$	
MC-ECM-02	0	0	-392	-1,325,863	-40	\$130,303	9,703	727	\$210,562	687	\$340,865	\$4,916,258

c) Calculation Methodology

The savings have been modeled based on a bin type analysis as per the Energy Balance. The bin model is calibrated with utility data.

d) Constructability

The equipment siting has not been finalized as we have not completed any schematic designs at this stage. We have carried 30% contingency for all ECMs, 20% in the cost consultant and an additional 10% included in the TPC.

MC-ECM-03: Battery Energy Storage System (BESS)

a) Overview

To further enable demand response and GA avoidance 3MWh hours of battery storage will be installed in the central heating plant. The batteries will be purchased in a self-contained unit and installed in a stacked manner near the electrical infrastructure. The 3MWh of capacity will provide 1MW of demand response capacity.

There are multiple benefits to the battery storage systems as they can be charged overnight when electricity is both cheap and clean with a lower carbon content than the marginal during daytime operation. The conversion efficiency of the batteries is also very high at over 90%. Containerized solutions provide an advantage for noise mitigation and the ability to relocate generator in future to accommodate relocation of the Central Plant and/or Nodal Plant Design.

Scope of Work:

Supply a containerized BESS solution 1MW @ 3 hours (3MWh) batteries with required HVAC, controls, etc.

Objectives Supported

- Build resilient low carbon systems

Principals Applied

- Balance carbon with cost
- Reach beyond our own assets
- Foster innovative solutions



Nodal Plant Option

The U of T is also considering connecting the McCaul cluster the Master Plan Nodal Plant Design currently under design both electrically and thermally. This will need to be considered at the next stage of detailed design and what's the best for U of T long term.

b) Economics and Other Benefits

The savings are focused solely on demand management and displacing GA peak events. We have also included the demand response revenue. We will need to include additional operational costs and equipment renewal to maintain the BESS over the life of the project.

ECM ID	Electrical Savings						Thermal Savings			Saving Totals		Cost Est w/o TPC
	kW ^{DR}	kW ^{GA}	kW ^{Pk}	kWh	tCO2e	\$	MMBtu	tCO2e	\$	tCO2e	\$	
MC-ECM-03	750	1,000	0	0	0	\$37,500	0	0	\$0	0	\$37,500	\$2,743,407

c) Calculation Methodology

Savings are modeled upon switching from Class B to Class A and displacement of Class A coincident peak. Best case is achieving 5/5 peaks or no cost impact for the GA Demand component with the cost benefit based on the lower HOEP rate cost vs Class B rate cost. To be conservative, we have based our calculations on capturing 3.5 out of the 5 GA peaks. Should U of T achieve all 5/5 peaks the savings for the demand component would be zero and overall savings would be increased since we have only assumed 3.5/5 peaks.

d) Constructability

The equipment siting has not been finalized. There is space around the site. We have assumed a typical installation and close to an electrical connection with no added structural work or the like. Since these are a based on containerized solution they can be relocated to suit.



MC-ECM-04: Combine Elect Service and Upgrade (+3MW)

a) Overview

As part of our strategy to electrify McCaul's 3 buildings we're proposing to change from the current Class B to a Class A rate. By electrifying the heating to electric should put us into the 1000kW minimum demand threshold for Class A. In addition, we would be required to tie all three buildings together electrically to achieve the new rate Class A.

The measure is in line with the overarching Nodal Strategy that our electrical service group has been taking elsewhere on campus. It allows for larger targeted demand response items for any storage systems on the node, which may indeed have a carbon effect since they will typically be used on peak days when the grid has a likely higher concentration of CO₂/kW as the gas-fired plant dispatched for generation.

Based on preliminary load sizing we expect there to be another 1.7MW of peak electric load. When combined with existing 0.8MW we would require approx. 3MW in total. We're proposing to build a customer owned HV substation service, consolidating the three existing buildings, proposed thermal (electric if decided) loads, and any future loads such as the Steward building. Other considerations include the renewal of the HA/EX/OA LV main electrical distribution systems, and emergency generators from diesel to renewable nature gas.

Objectives Supported

- *Build resilient low carbon systems*
- *Renew existing and aged utility infrastructure*

Principals Applied

- *Balance carbon with cost*
- *Reach beyond our own assets*
- *Foster innovative solutions*



Nodal Plant Option

The McCaul cluster is part of the new Master Plan Nodal system design and referred to as Node 8. The U of T is considering connecting the McCaul Node 8, to the closest Nodal System, referred to as Node 5, both electrically and thermally, currently under conceptual design by WSP at the writing of this report. This will need to be considered and analyzed at the next stage of detailed design for what's the best solution for U of T long-term.

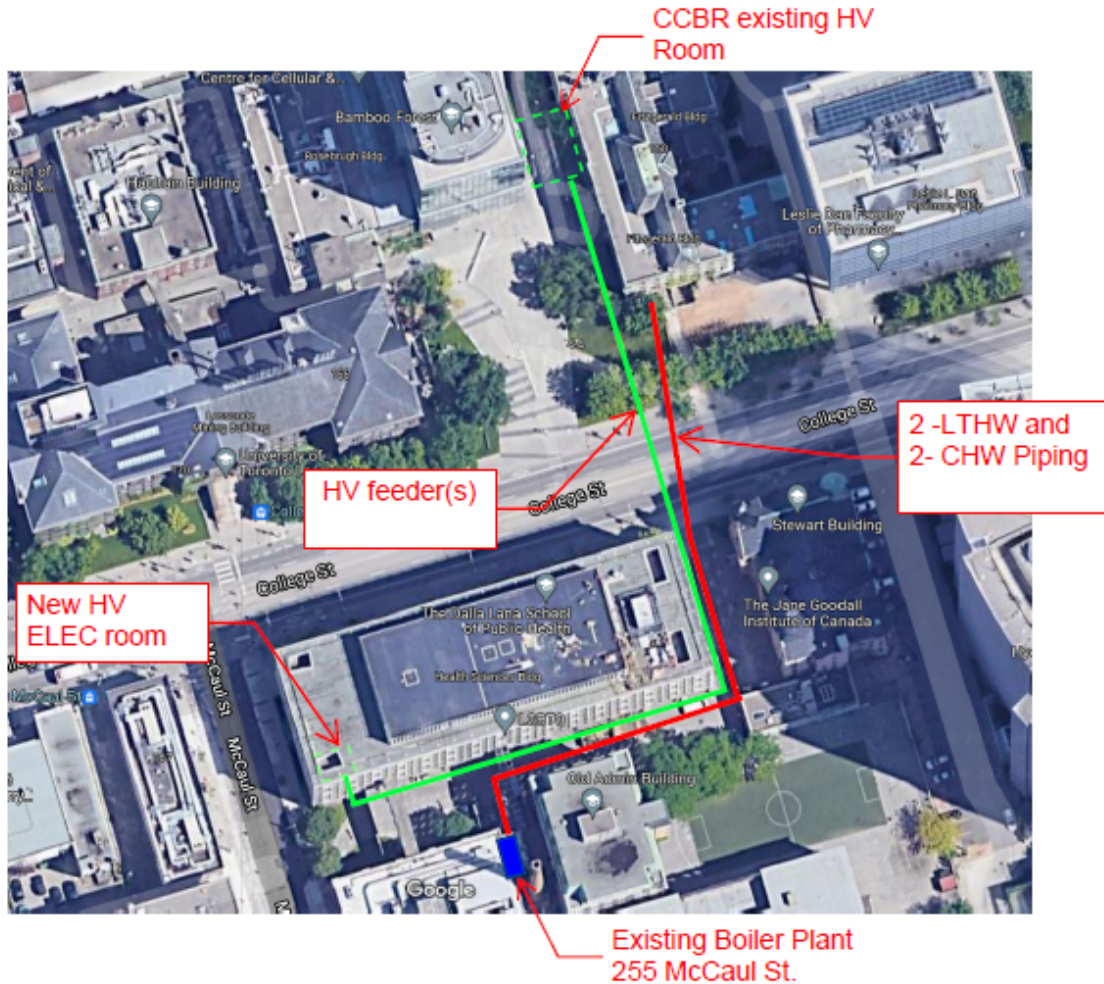

Figure 26: Nodal Integration Option

b) Economics and Other Benefits

No savings or operational costs have been included.



ECM ID	Electrical Savings						Thermal Savings			Saving Totals		Cost Est w/o TPC
	kW ^{DR}	kW ^{GA}	kW ^{PK}	kWh	tCO ₂ e	\$	MMBtu	tCO ₂ e	\$	tCO ₂ e	\$	
MC-ECM-04	0	0	0	0	0	\$0	0	0	\$0	0	\$0	\$4,593,612

c) Calculation Methodology

No savings have been included.

d) Constructability

The equipment siting has not been finalized as we have not completed any schematic designs at this stage. We have carried 30% contingency for all ECMs.

MC-ECM-05: Electrify DHW

a) Overview

Three gas fired domestic hot water heaters provide domestic hot water (DHW) for the buildings EX and OA. The DHW heaters are in the boiler room.

We're proposing to install new 60-kW electric DHW boiler in HA basement mechanical room and feed 2 x DHW tanks.

Nodal Plant Option

The U of T is also considering connecting the McCaul cluster to the Nodal System (Node 8) currently under design both electrically and thermally. This will need to be considered at the next stage of detailed design.

Objectives Supported

- Build resilient low carbon systems
- Improve building EUI

Principals Applied

- Balance carbon with cost
- Reach beyond our own assets
- Foster innovative solutions

b) Economics and Other Benefits

Installation costs are included in MC-ECM-02.

ECM ID	Electrical Savings						Thermal Savings			Saving Totals		Cost Est w/o TPC
	kW ^{DR}	kW ^{GA}	kW ^{PK}	kWh	tCO ₂ e	\$	MMBtu	tCO ₂ e	\$	tCO ₂ e	\$	
MC-ECM-05	0	0	-113	-225,391	-7	-\$21,646	769	58	\$16,693	51	-\$4,953	\$0

c) Calculation Methodology

Gas utility data was utilized for conversion plus usage for HA based on the utility data.



d) Constructability

The equipment siting has not been finalized as we have not completed any schematic designs at this stage. We have carried 30% contingency for all ECMs.

MC-ECM-06: Upgrade BAS + DCV and Recommission in HA

a) Overview

The mechanical systems and their control equipment are in generally good condition but are now over 15 years old and would benefit from this measure. This may entail upgrading of existing DDC points and addition of some new DDC points to allow the systems to follow the building loads more closely. The BTU meters which have not been working properly in the past two years for heating and cooling BTU meter is required to be calibrated, and re-commissioning.

Objectives Supported

- Build resilient low carbon systems
- Renew existing and aged utility infrastructure
- Improve comfort conditions

Principals Applied

- Balance carbon with cost
- Reach beyond our own assets
- Foster innovative solutions

b) Economics and Other Benefits

Only utility savings have been included at this stage. We will need to understand what the differential operating costs are during the next detailed engineering phase.

ECM ID	Electrical Savings						Thermal Savings			Saving Totals		Cost Est w/o TPC
	kW ^{DR}	kW ^{GA}	kW ^{PK}	kWh	tCO ₂ e	\$	MMBtu	tCO ₂ e	\$	tCO ₂ e	\$	
MC-ECM-06	0	0	0	61,003	2	\$1,422	2,827	212	\$61,346	214	\$62,768	\$543,213

c) Calculation Methodology

To be provided.

d) Constructability

No issues identified at this stage.



MC-ECM-07: Upgrade BAS + DCV and Recommission in EX

a) Overview

The mechanical systems and their control equipment are in generally good condition but are now over 15 years old and are recommended for upgrade. This may entail upgrading of existing DDC points and addition of some new DDC points to allow the systems to follow the building loads more closely. The BTU meters which have not been working properly in the past two years for heating and cooling BTU meter are required to be calibrated, and re-commissioning.

Objectives Supported

- Build resilient low carbon systems
- Renew existing and aged utility infrastructure
- Improve comfort conditions

Principals Applied

- Balance carbon with cost
- Reach beyond our own assets
- Foster innovative solutions

b) Economics and Other Benefits

Only utility savings have been included at this stage. We will need to understand what the differential operating costs are during the next detailed engineering phase.

ECM ID	Electrical Savings						Thermal Savings			Saving Totals		Cost Est w/o TPC
	kW ^{DR}	kW ^{GA}	kW ^{PK}	kWh	tCO _{2e}	\$	MMBtu	tCO _{2e}	\$	tCO _{2e}	\$	
MC-ECM-07	0	0	0	33,844	1	\$789	158	12	\$3,422	13	\$4,210	\$236,972

c) Calculation Methodology

We have calculated savings based on a conservative 15% reduction of the HVAC loads as per the Energy Balance.

d) Constructability

Costing is based on previous BAS retrofits at the university. We will install this measure in many areas of the facility including in academic areas so that requires careful coordination. We will create a detailed communication and delivery plan due to the nature of this installation, before work commences.



MC-ECM-08: Upgrade BAS + DCV and Recommission in OA

a) Overview

The mechanical systems and their pneumatic control equipment are in fair conditions locally, but they are not connected with any central energy management system. It is recommended that this BAS be connected to the central ERMS and building re-commissioning activities, such as system tune-up, setpoint calibrations, control sequence re-adjustment, and preventative maintenance corrections, etc., be preformed.

Meanwhile, M&V&T program follows IPMVP protocol as a guidance, the savings can be properly quantified and accounted. The ongoing Cx activity ensures the persistent savings to be maintained over the time.

Objectives Supported

- *Build resilient low carbon systems*
- *Improve comfort conditions*
- *Renew existing and aged utility infrastructure*

Principals Applied

- *Balance carbon with cost*
- *Reach beyond our own assets*
- *Foster innovative solutions*

b) Economics and Other Benefits

Only utility savings have been included at this stage. We will need to understand what the differential operating costs are between existing operation and proposed during the next detailed engineering phase.

ECM ID	Electrical Savings						Thermal Savings			Saving Totals		Cost Est w/o TPC
	kW ^{DR}	kW ^{GA}	kW ^{PK}	kWh	tCO2e	\$	MMBtu	tCO2e	\$	tCO2e	\$	
MC-ECM-08	0	0	0	12,479	0	\$291	58	4	\$1,262	0	\$1,552	\$441,133

c) Calculation Methodology

We have calculated savings based on a conservative 15% reduction of the HVAC loads as per the Energy Balance.

d) Constructability

Costing is based on previous BAS retrofits at the university. We will install this measure in many areas of the facility including in academic areas so that requires careful coordination. We will create a detailed communication and delivery plan due to the nature of this installation, before work commences.



MC-ECM-09: Install Solar PV at HA

a) Overview

The roof of the penthouse has sufficient open area to support a photovoltaic array that would help offset the building's grid electricity usage. Per AMP's study, a total 342 PV panels for 120kWac capacity is proposed to be installed on the roof. The potential energy savings of rooftop solar PV is estimated at 139,725 kWh/annual.

Scope of Work:

- Approx. 342 panels
- 150kW, outdoor rated inverter installed on the roof
- Outdoor rated rapid shutdown box

Objectives Supported

- Build resilient low carbon systems
- Include renewables

Principals Applied

- Balance carbon with cost
- Reach beyond our own assets
- Foster innovative solutions



Figure 27: Proposed PV Layout

- Outdoor rated DC disconnect and combiner
- All local LDC requirements

b) Economics and Other Benefits

Savings are based on displacing the electric usage at the new electric rate. We will need to include operational costs with equipment renewal for invertors for example. This will be detailed in the next phase of development.

ECM ID	Electrical Savings						Thermal Savings			Saving Totals		Cost Est w/o TPC
	kW ^{DR}	kW ^{GA}	kW ^{PK}	kWh	tCO2e	\$	MMBtu	tCO2e	\$	tCO2e	\$	
MC-ECM-09	0	75	0	139,725	4	\$3,256	0	0	\$0	4	\$3,256	\$993,460

c) Calculation Methodology

Savings are based on AMP's study.

d) Constructability

Costing is based on typical rooftop installations with no added structural requirements. Systems can be scaled and/or removed if costs for structural prove prohibitive. We will need an approved parallel grid connection from Toronto Hydro.



MC-ECM-10: Install Solar PV on OA

a) Overview

According to the site situation and roof conditions, a small solar PV project is recommended based on a RETScreen Expert analysis. It is proposed to install 15kW of Solar PV on the roof of OA.

Scope of Work:

- 30kW, outdoor rated inverter installed on the roof
- Outdoor rated rapid shutdown box
- Outdoor rated DC disconnect and combiner
- All local LDC requirements

Objectives Supported

- Build resilient low carbon systems
- Include renewables

Principals Applied

- Balance carbon with cost
- Reach beyond our own assets
- Foster innovative solutions

b) Economics and Other Benefits

Savings are based on displacing the electric usage at the site based on synchronous grid operation.

ECM ID	Electrical Savings						Thermal Savings			Saving Totals		Cost Est w/o TPC
	kW ^{DR}	kW ^{GA}	kW ^{PK}	kWh	tCO2e	\$	MMBtu	tCO2e	\$	tCO2e	\$	
MC-ECM-10	0	9	0	16,900	1	\$394	0	0	\$0	1	\$394	\$153,120

c) Calculation Methodology

Savings are based on RETScreen for Toronto.

d) Constructability

Costing is based on typical rooftop installations with no added structural requirements. Systems can be scaled and/or removed if costs for structural prove prohibitive. We will need an approved parallel grid connection with Toronto Hydro.



MC-ECM-11: Upgrade Heating Radiators in OA

a) Overview

The perimeter radiant heating system (units and piping included) are approaching end of life. It is proposed to replace with new more energy-efficient models. The retrofit will require the system to connect and be designed with the LTHW system (135°F) and maintaining the same heating output, fan coil units appear to be a suitable alternative to the original units.

The additional opportunity of energy savings is controllability on the individual unit through temperature reset and occupancy sensing. There are approximately 24 units per floor for 5 floors, giving a total of 120 units for the entire building requiring conversion. Each unit has an output of 600 btu/ft/hr with a length of 4ft, providing 2400 btu/hr. An equivalent output of fan coil unit should be sized to replace each of the existing radiant units.

Objectives Supported

- Build resilient low carbon systems
- Renew existing and aged utility infrastructure
- Improve comfort conditions

Principals Applied

- Balance carbon with cost
- Reach beyond our own assets
- Foster innovative solutions

Nodal Plant Option

The U of T is also considering connecting the McCaul cluster the Master Plan Nodal Plant Design currently under design both electrically and thermally. This will need to be considered at the next stage of detailed design.

b) Economics and Other Benefits

Measure is not included in current.

ECM ID	Electrical Savings						Thermal Savings			Saving Totals		Cost Est w/o TPC
	kW ^{DR}	kW ^{GA}	kW ^{PK}	kWh	tCO2e	\$	MMBtu	tCO2e	\$	tCO2e	\$	
MC-ECM-11	0	0	0	0	0	\$0	0	0	\$0	0	\$0	\$0

c) Calculation Methodology

Measure is not included at this stage of development.

d) Constructability

Measure is not included at this stage of development.



5.6 Leslie Dan Pharmacy (PB)

Built in 2006, the Leslie L Dan Pharmacy building is 13-story laboratory building. The building facilitates chemical labs, classrooms, offices, meeting spaces and a large atrium. The building is provided with district chilled water in MSB and steam from the U of T central plant.

5.6.1 Existing Conditions

Heating

Booster pumps are provided for the incoming district chilled water which is delivered directly to AHU cooling coils. District steam is delivered via pressure reducing stations direct to AHU steam coils, steam humidifiers, process loads (i.e., autoclaves), steam-to-hot water shell-n-tube heat exchangers that convert steam to hot water for heating hot water distribution through the building, and steam-to-domestic hot water heaters. There is a steam condensate return system to return the steam condensate back to the central plant. A glycol heat recovery system is provided to recover energy from lab exhaust systems to provide pre-heat at associated OA make-up air AHUs.

The primary HVAC system is a VAV reheat system with perimeter heating by radiant ceiling panels. The main entrance is a relatively large, glazed structure with bare fin radiators installed on intermittent horizontal mullions.

Ventilation & Air Handlers

The air handling systems are zoned as follows:

- AHU-1 (penthouse) – South Lab and the 4th and 5th floor offices Ventilation
- AHU-2 (penthouse) – North Lab Ventilation and the 6th to the 8th floors teaching labs)
- AHU-3 (penthouse) – Lab Supply (9th, 10th, 11th, 12th floor), west labs, and engineer's office
- (AHU-4 (penthouse) – Lab Supply (9th, 10th, 11th, 12th floor), and Centre labs
- AHU-5 (penthouse) – Lab Supply (9th, 10th, 11th, 12th floor), East labs, and south corridors)
- AHU- 6 (penthouse) – VAV (7th and 8th floor) also known as teaching labs
- AHU-7 (penthouse) – VAV (N/E 6th, 9th and 11th floor) (North offices and hallways)
- AHU-8 (penthouse) – VAV (N/W 7th, 8th, 10th, and 12th floor) (North offices and hallways)
- AHU-9 (basement) – VAV (1st, 2nd and 3rd floor) serves study rooms, and serves pods, B2 and B3 interior located in B2 level
- AHU-10 (basement) – Atrium and serves 200K, 250K, 300K and B1 level. Located in B2 level.
- AHU-11 (basement) – CV Auditorium AHU-12 (Located in B2 level)
- AHU-12 located in B2 level (Serves lecture hall B250).



Laboratory exhaust fans serve the chemistry labs and fume hoods. Fume hoods operate at 0.5 m/s (100 fpm) based with no demand control. As discussed above, there is a glycol recovery system that recovers energy via a run-around-coils between the laboratory exhaust and AHU make-up air units (AHU-3, AHU-4, and AHU-5)

5.6.2 Energy Conservation Measures (ECMs)

The following ECMs are proposed for further analysis.

PB-ECM-01: Low Temperature Hot Water (LTHW) Conversion

a) Overview

This measure is part of the campus wide LTHW project and the building heating systems will be connected with the Master Plan Nodal System (Node 5), LTHW loop. The existing steam coils in the AHUs will be changed to new low temperature glycol coils (135F), and perimeter heating system will remain but run on LTHW, which may be topped up by HTHW converted from steam only if extra heating is required. The radiant panels will require further investigation due to current high supply water temperature requirements (180F).

Objectives Supported

- Build resilient low carbon systems
- Renew existing and aged utility infrastructure

Principals Applied

- Balance carbon with cost
- Reach beyond our own assets
- Foster innovative solutions

b) Economics and Other Benefits

We have not included any utility reduction benefit at this stage. This ECM is designed around future opportunities to utilize either Nodal LTHW or additional EAHR. We do not expect any operation cost changes.

ECM ID	Electrical Savings						Thermal Savings			Saving Totals		Cost Est w/o TPC
	kW ^{DR}	kW ^{GA}	kW ^{Pk}	kWh	tCO ₂ e	\$	MMBtu	tCO ₂ e	\$	tCO ₂ e	\$	
PB-ECM-01	0	0	0	0	0	\$0	0	0	\$0	0	\$0	\$2,056,188

c) Calculation Methodology

We have not included any utility reduction benefit at this stage.

d) Constructability

A description of this ECM and building drawings were provided to the costing consultant. The equipment siting or piping locations has not been finalized as we have not completed any schematic designs at this stage. We have carried 30% contingency for all ECMs.



PB-ECM-02: Adiabatic Humidification

a) Overview

When converting from steam to low temperature hot water heating systems it is also worth considering converting steam-based humidification systems to low temperature compatible humidification systems.

An adiabatic system is one such option to consider over the steam-based system currently in operation. This type of system creates small particles of water in the air stream that absorb heat energy from the air to evaporate the water and raise the relative humidity. This means that heat energy which has been created efficiently by a heat pump with its high COP is now being used to evaporate the water and create the required humidity levels, rather than using energy from the central steam plant being delivered to the air handler at relatively low efficiencies.

However, given this has not yet been proven to the operating staff at U of T, we are recommending a pilot installation be performed in a less critical building. Should this prove successful we would consider moving to the next step in the process.

To meet ASHRAE standard 170 requirements in the prevention of legionellae when using the adiabatic systems in health care or laboratory environments, only the spray mist systems are acceptable. From ASHRAE Standard 170:

6.6.3 Adiabatic Atomizing Humidifier Requirements

Humidifier water shall be treated with a reverse osmosis process, a UV-C sterilization light source, and a submicron filter. Informative Note: For more information, see ASTM (2011). Treated humidifier water shall be continuously circulated from the source to the humidifier valves. All valves, headers, and piping not part of the recirculation loop shall drain completely when not in use. Water temperature shall be maintained within the control limits in the legionellosis risk management plan. (Informative Note: For more information, reference ASHRAE Guideline 12 and ASHRAE Standard 188.)

Ports suitable for testing water quality shall be provided in the treated humidifier water piping system. Moisture eliminators shall be provided as required to prevent moisture accumulation in ductwork. Water purity shall meet or exceed potable water standards at the point where it enters the ventilation system, space, or water-vapor generator.

Objectives Supported

- Build resilient low carbon systems
- Improve worker safety
- Improve comfort conditions

Principals Applied

- Balance carbon with cost
- Reach beyond our own assets
- Foster innovative solutions



The proposed humidification system consists of R.O. water purification, pump station, Storage tank w/ UVC lamp, pump, high pressure water spray system.

b) Economics and Other Benefits

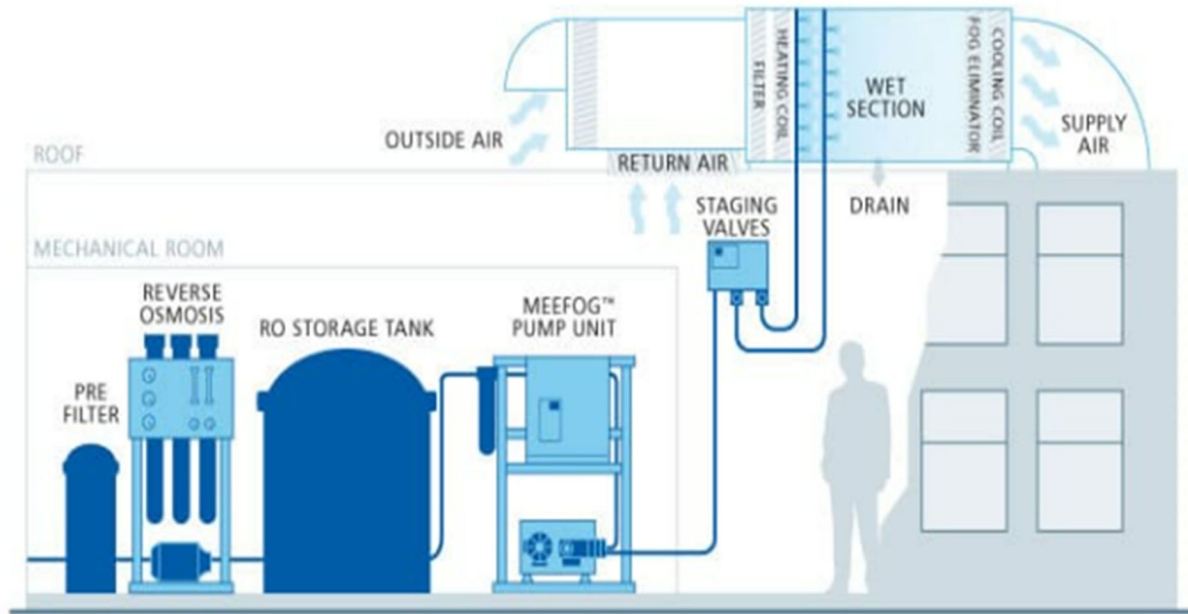

Figure 28: Typical Adiabatic Schematic

This ECM is to be vetted but we have carried utility savings and not added operational requirements for the added water treatment systems as a place holder. The maintenance cost will be finalized during the vetting process of a pilot.

ECM ID	Electrical Savings						Thermal Savings			Saving Totals		Cost Est w/o TPC
	kW ^{DR}	kW ^{GA}	kW ^{PK}	kWh	tCO _{2e}	\$	MMBtu	tCO _{2e}	\$	tCO _{2e}	\$	
PB-ECM-02	0	0	0	-243,258	-7	-\$5,669	2,491	131	\$20,544	123	\$14,875	\$304,418

c) Calculation Methodology

We have calculated the savings based on the modelled fan humidity usage and utilized the heat pump for heating with a very conservative efficiency of COP of 3. This aligns with billing data.

d) Constructability

This type of humidification system does require more space for absorption of humidity as compared to conventional steam type system. While there are many examples of functional operating systems in critical environments, due diligence is required as to not cause detrimental effects also observed. We are recommending that a pilot installation be considered and built into the process in a less critical building prior to moving ahead with this ECM.



PB-ECM-03: Heat Recovery Chiller

a) Overview

Basis of design every active heat pump heat recovery system requires both a heat source as well as a heat sink. An exhaust air heat pump utilizes the exhaust air from a buildings ventilation system has a constant heat source at a temperature of approximately 72°F to 74°F. A cooling coil is placed in the exhaust airstream to cool the exhaust air down to close to 32°F, in doing so energy from the exhaust airstream is transferred to the evaporator circuit of the heat pump and is leveraged as a heat source to create higher grade heat on the condenser circuit. The condenser circuit is connected to the heating coils for the air handling units and surplus heat is sent to perimeter and domestic hot water heating

Objectives Supported

- Build resilient low carbon systems
- Reduce building EUI

Principals Applied

- Balance carbon with cost
- Reach beyond our own assets
- Foster innovative solutions

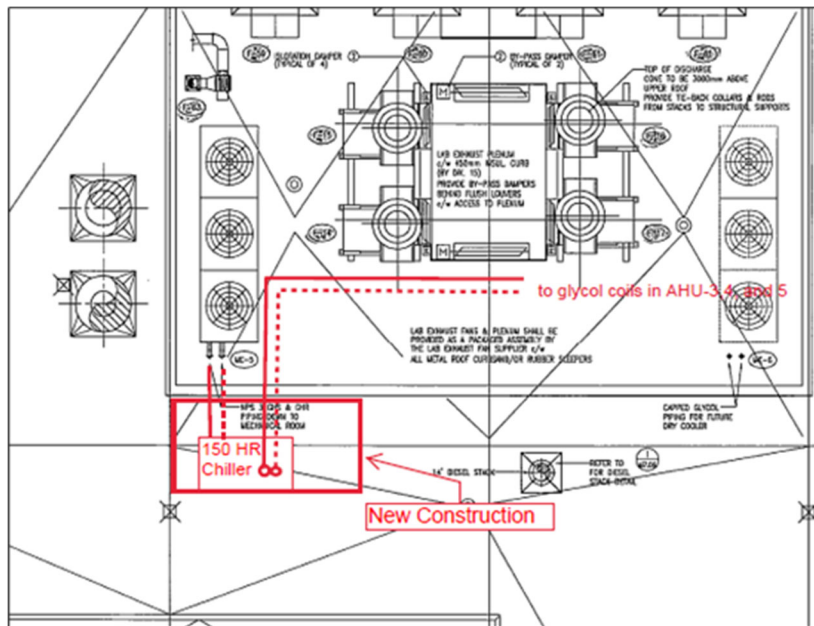

for cooling and five for heating. This building has an existing run around heat recovery loop. The heat recovery coils that have been installed from the run around

Figure 29: Proposed Heat Recovery Chiller Location

system would be modified, the exhaust fans would also be resized modified, or replaced (if necessary), to provide the proper airflows. The glycol heat recovery loop would be modified to place a heat pump between the heating portions of the runaround loop and the cooling portions (heat source) of the runaround loop thus leveraging the refrigeration cycle to provide greater efficiency. This has the additional benefit of providing higher grade heat to preheat class 4 laboratory systems requiring 100% fresh air. The

systems.

In a laboratory environment, exhaust air heat recovery can typically recover enough heating energy to offset approximately 40% of the total building heating needs. Additional heat recovery chiller opportunities exist when there are simultaneous heating and cooling. The heat recovery chiller will provide the buildings base load requirements for chilled water needs throughout the winter months while providing an equivalent of 1.25 times as much heating energy to supply the perimeter heating requirements. We have applied the COP of three



high COP of the heat pump as well as the higher-grade heat both provide distinct advantages over a run around loop style system, where the run around typically has an overall seasonal efficiency of 40% the heat pump heat recovery modification should yield an overall efficiency exceeding 130%, three times more than the runaround system.

The 100% OA air-handling units (AHU-3, AHU-4, and AHU-5) have a total air flowrate of 73,000 cfm. The proposed HR chiller capacity is of 150-Ton

b) Economics and Other Benefits

Savings are based on utility savings and not added operational requirements or associated additional costs. We do expect added costs for the new equipment to be finalized during detailed design.

ECM ID	Electrical Savings						Thermal Savings			Saving Totals		Cost Est w/o TPC
	kW ^{DR}	kW ^{GA}	kW ^{PK}	kWh	tCO ₂ e	\$	MMBtu	tCO ₂ e	\$	tCO ₂ e	\$	
PB-ECM-03	0	0	-195	-1,179,302	-35	-\$55,776	12,075	633	\$99,594	597	\$43,818	\$2,130,925

c) Calculation Methodology

We have modelled the savings on maximum heat recovery availability from exhaust air and balanced utility data. See Energy Balance for calculation.

d) Constructability

A description of this ECM and building drawings were provided to the costing consultant. The equipment siting or piping locations has not been finalized as we have not completed any schematic designs at this stage. We have carried 30% contingency cost for all ECMs to cover any added scope of work.

PB-ECM-04: Upgrade BAS + DCV and Recommission

a) Overview

The measure recommends demand control ventilation, BAS optimization, and recommissioning. These include an upgrade to the building automation system as well as attention to building operation including building pressurization. This will also include optimizing building schedules as well as occupied and unoccupied temperature set points. Additional items are recommended: energy-efficient sequences, static reset, installing variable frequency drives on equipment.

Objectives Supported

- Build resilient low carbon systems
- Improve comfort conditions
- Renew existing and aged utility infrastructure

Principals Applied

- Balance carbon with cost
- Reach beyond our own assets
- Foster innovative solutions



b) Economics and Other Benefits

We have only included utility savings and no operational savings at this stage.

ECM ID	Electrical Savings						Thermal Savings			Saving Totals		Cost Est w/o TPC
	kW ^{DR}	kW ^{GA}	kW ^{PK}	kWh	tCO2e	\$	MMBtu	tCO2e	\$	tCO2e	\$	
PB-ECM-04	0	0	0	167,396	5	\$3,901	2,485	130	\$20,500	135	\$24,401	\$461,184

c) Calculation Methodology

We have calculated savings based on a conservative 15% reduction of the HVAC loads as per the Energy Balance.

d) Constructability

Costing is based on previous BAS retrofits at the university. We are proposing to install this measure in many areas of the facility including in academic areas so that requires careful coordination. We will create a detailed communication and delivery plan due to the nature of this installation, before work commences.

PB-ECM-05: Battery Energy Storage System (BESS)

a) Overview

To further enable demand response and GA avoidance 1.5MWh hours of battery storage will be installed. The batteries will be purchased in a self-contained unit and installed in a stacked manner near the electrical infrastructure. The 1.5MWh of capacity will provide 500kW of demand response capacity.

There are multiple benefits to the battery storage systems as they can be charged overnight when electricity is both cheap and clean with a lower carbon content than the marginal during daytime operation. The conversion efficiency of the batteries is also very high at over 90%. Containerized solutions provide an advantage for noise mitigation and the ability to relocate generator in future to accommodate relocation of the Central Plant and/or Nodal Plant Design.

Objectives Supported

- Build resilient low carbon systems

Principals Applied

- Balance carbon with cost
- Reach beyond our own assets
- Foster innovative solutions

Scope of Work:

Supply a containerized BESS solution 500kW @ 3 hours (1.5MWh) batteries with required HVAC, controls, etc.



b) Economics and Other Benefits

The savings are focused solely on demand management and displacing GA peak events. We will need to include added operational cost and equipment renewal for the project life.

ECM ID	Electrical Savings						Thermal Savings			Saving Totals		Cost Est w/o TPC
	kW ^{DR}	kW ^{GA}	kW ^{pk}	kWh	tCO2e	\$	MMBtu	tCO2e	\$	tCO2e	\$	
PB-ECM-05	375	242	0	0	0	\$117,243	0	0	\$0	0	\$117,243	\$1,376,261

c) Calculation Methodology

Calculation is based on displacing 3.5 out of the 5 GA peaks.

d) Constructability

The equipment siting has not been finalized. There is space around the site. We have assumed a typical installation and close to an electrical connection with no added structural work or the like. Since these are based on containerized solution it can be relocated to suit in more suitable location.

PB-ECM-06: Investigate Lab VAV/DCV

a) Overview

The very nature of work being conducted in research facilities requires proper ventilation be maintained to ensure a safe environment for all occupants. And the energy consumption of labs must be taken into consideration when planning energy efficiency initiatives.

Maintaining 100% fresh air ventilation in a life science facility translates into large amounts of energy being consumed. There is an opportunity to introduce Demand Control Ventilation in the Labs, by implementing a Lab Demand Control Ventilation (DCV) system. Basically, varying the rate based on real-time air quality data is an ideal way to get it done. That’s how to achieve significant energy savings and maintain a healthy building environment.

Objectives Supported

- Build resilient low carbon systems
- Improve workplace safety

Principals Applied

- Balance carbon with cost
- Reach beyond our own assets
- Foster innovative solutions



Critical indoor parameters are monitored continuously to provide the data input needed to adjust ventilation rates for any given situation. On top of energy savings, the environmental health and safety team have access to Indoor Environmental Quality (IEQ) information to ensure safety and proper lab protocols are consistently being adhered to.



This can provide significant energy reduction with very attractive financial returns. This is recommended for further study during the next stage of project development.

b) Economics and Other Benefits

No savings have been included at this stage.

ECM ID	Electrical Savings						Thermal Savings			Saving Totals		Cost Est w/o TPC
	kW ^{DR}	kW ^{GA}	kW ^{PK}	kWh	tCO ₂ e	\$	MMBtu	tCO ₂ e	\$	tCO ₂ e	\$	
PB-ECM-06	0	0	0	0	0	\$0	0	0	\$0	0	\$0	\$0

c) Calculation Methodology

Measure financials are not included at this stage of the development process.

d) Constructability

Measure financials are not included at this stage of the development process.



5.7 Campus Wide

The following ECMs are being considered for opportunities in addition to the specific building ECMs and focuses on demand management for GA and DR.

5.7.1 BCIT (BA) Energy Conservation Measures (ECMs)

The following ECMs are recommended for further analysis.

BA-ECM-01: Ice Storage System (ISS)

a) Overview

There is an excellent opportunity to install ice storage to offset chiller power during peak summer cooling days. The peak summer cooling days coincide extremely well with the 5CP demand on the Ontario grid. The low purchase price and simplicity of operation make this an attractive candidate for additional demand response.

Each installation is intended to provide 3 hours of block cooling by slowly melting the ice tanks, the tanks are then re-frozen with a dedicated ice chiller steadily loaded over an 18-hour off-peak period.

Scope of Work

- Supply and install an equivalent Trane dual temp CVHF500 chiller
- Supply and an equivalent Trane ice making system capable of displacing 1500-Tons at 3 hrs or 4,050 ton-hrs.

Objectives Supported

- Build resilient low carbon systems

Principals Applied

- Balance carbon with cost
- Reach beyond our own assets
- Foster innovative solutions

Item	BA	Units/Notes
Peak Electrical Cooling Load	1,500	Tons
Number of Hours to Load Shift	3	Hours
Diversity	0.9	
Load Shift (Ton-Hrs)	4,050	Ton-Hours
Number of 1500C Modules	13	
Number of Hours to Load Shift	2	
Load Shift (Ton-Hrs)	2,700	Ton-Hours
Number of 1500C Modules	8	

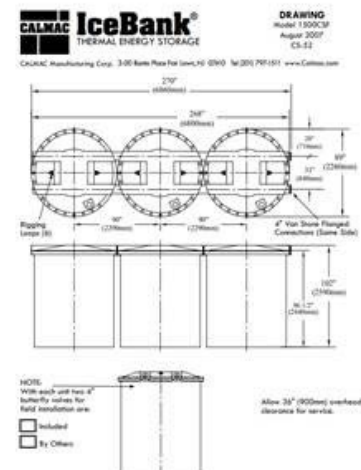

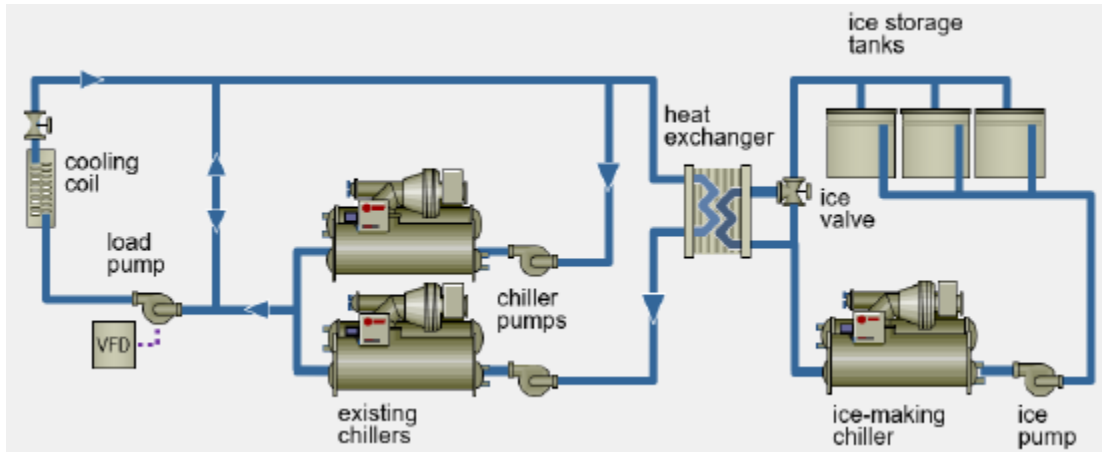

Figure 30: Proposed Ice Storage Schematic

b) Economics and Other Benefits

We have only included utility savings and not added operational costs for the added equipment.

ECM ID	Electrical Savings						Thermal Savings			Saving Totals		Cost Est w/o TPC
	kW ^{DR}	kW ^{GA}	kW ^{PK}	kWh	tCO ₂ e	\$	MMBtu	tCO ₂ e	\$	tCO ₂ e	\$	
BA-ECM-01	1,200	1,200	0	0	0	\$548,639	0	0	\$0	0	\$548,639	\$2,699,658

c) Calculation Methodology

Preliminary sizing and savings provided by Trane. We have not included the decrease in COP due to higher lift that can be offset in part due to lower nighttime temperatures. We do recommend this be included during detailed design and energy savings modelling,

d) Constructability

The equipment siting has not been finalized. Some suggested locations for consideration include underground parking lot, South of BCIT water feature, or Roof/PH. Schematic design sketches are recommended as next step.



5.7.2 Convocation Hall (CH)

The following ECMs are being considered for opportunities in addition to the specific building ECMs and focuses on demand management for GA and DR.

CH-ECM-01: Ice Storage Demonstration Measure

a) Overview

Many years ago, Convocation Hall was cooled by ice. We are proposing to install a small ice storage system for demonstration purposes.

b) Economics and Other Benefits

No savings are included.

ECM ID	Electrical Savings						Thermal Savings			Saving Totals		Cost Est w/o TPC
	kW ^{DR}	kW ^{GA}	kW ^{PK}	kWh	tCO _{2e}	\$	MMBtu	tCO _{2e}	\$	tCO _{2e}	\$	
CH-ECM-01	0	0	0	0	0	\$0	0	0	\$0	0	\$0	\$182,286

c) Calculation Methodology

No savings have been included at this stage.

d) Constructability

No issues have been identified at this stage.

Objectives Supported

- Build resilient low carbon systems

Principals Applied

- Balance carbon with cost
- Reach beyond our own assets
- Foster innovative solutions



5.7.3 Medical Sciences Building (MS)

The following ECMs are being considered for opportunities in addition to the specific building ECMs and focuses on demand management for GA and DR.

MS-ECM-01: Ice Storage System (ISS)

a) Overview

There is an excellent opportunity to install ice storage to offset chiller power during peak summer cooling days. The peak summer cooling days coincide extremely well with the 5CP demand on the Ontario grid. The low purchase price and simplicity of operation make this an attractive candidate for additional demand response.

Each installation is intended to provide 3 hours of block cooling by slowly melting the ice tanks, the tanks are then re-frozen with a dedicated ice chiller steadily loaded over an 18-hour off-peak period.

Scope of Work

- Supply and install an equivalent Trane dual temp CVHF1600 chiller
- Supply and an equivalent Trane ice making system capable of displacing 4,700-Tons at 2 or 3 hrs or 12,690 ton-hrs.

Objectives Supported

- Build resilient low carbon systems

Principals Applied

- Balance carbon with cost
- Reach beyond our own assets
- Foster innovative solutions

Item	MS	Units/Notes
Peak Electrical Cooling Load	4,700	Tons
Number of Hours to Load Shift	3	Hours
Diversity	0.9	
Load Shift (Ton-Hrs)	12,690	Ton-Hours
Number of 1500C Modules	40	
Number of Hours to Load Shift	2	
Load Shift (Ton-Hrs)	8,460	Ton-Hours
Number of 1500C Modules	26	

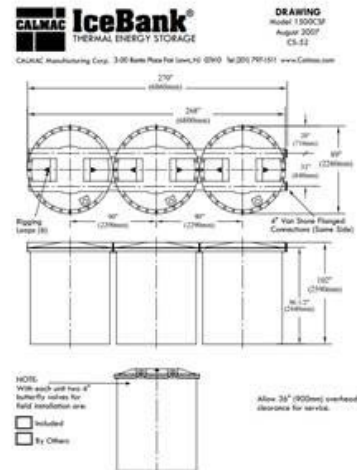

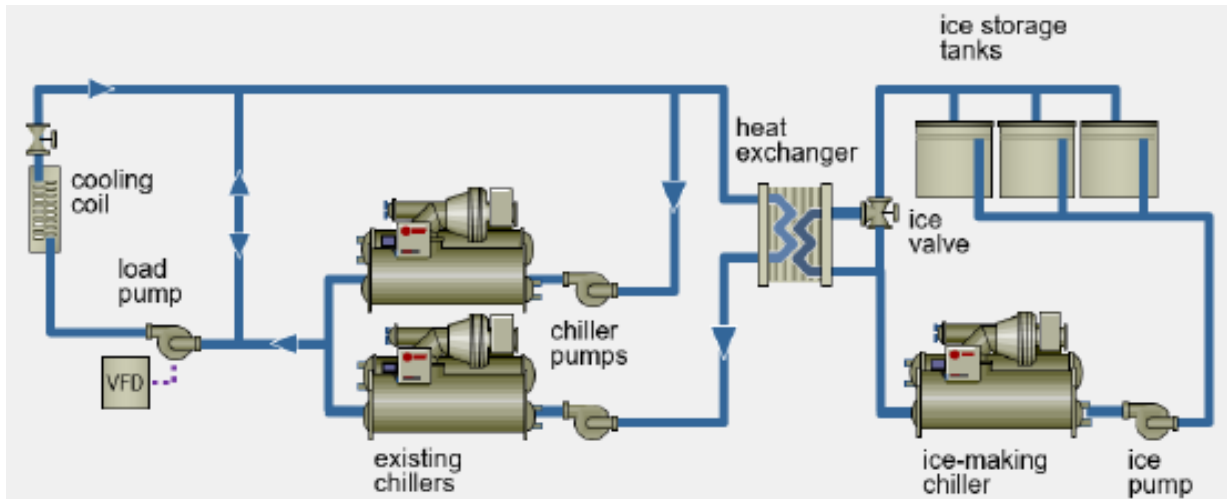

Figure 31: Proposed Ice Storage Schematic

b) Economics and Other Benefits

We have only included utility savings and not added operational costs for the added equipment. Added operational cost is expected and will be further defined during next stage of development.

ECM ID	Electrical Savings					\$	Thermal Savings			Saving Totals		Cost Est w/o TPC
	kW ^{DR}	kW ^{GA}	kW ^{Pk}	kWh	tCO _{2e}		MMBtu	tCO _{2e}	\$	tCO _{2e}	\$	
MS-ECM-01	3,760	3,760	0	0	0	-\$271,321	0	0	\$0	0	-\$271,321	\$8,175,535

c) Calculation Methodology

Preliminary sizing and savings provided by Trane. Savings are modeled upon switching from Class B to Class A and displacement of Class A coincident peak. Best case is achieving 5/5 peaks or no cost impact for the GA Demand component with the cost benefit based on the lower HOEP rate cost vs Class B rate cost. To be conservative, we have based our calculations on capturing 3.5 out of the 5 GA peaks. Should U of T achieve all 5/5 peaks the savings would be zero and overall savings would be increased.

d) Constructability

The equipment siting has not been finalized. There is limited space inside the Mechanical Room. Other potential locations include the exterior location outside MR or Roof/PH. Further investigation is required.



MS-ECM-02: Operate Steam Driven Chiller for Demand Management

a) Overview

To date, the operation of the MSB steam driven chiller has not been focused on demand response to reduce the CED’s peak demand factor (lowering the GA costs). At peak capacity this steam driven chiller can reduce 2,800-Tons of electric chiller operation.

b) Economics and Other Benefits

We have only included savings for displacing 3.5 of the 5 GA peaks.

Objectives Supported

- *Build resilient low carbon systems*

Principals Applied

- *Balance carbon with cost*
- *Reach beyond our own assets*
- *Foster innovative solutions*

ECM ID	Electrical Savings						Thermal Savings			Saving Totals		Cost Est w/o TPC
	kW ^{DR}	kW ^{GA}	kW ^{Pk}	kWh	tCO2e	\$	MMBtu	tCO2e	\$	tCO2e	\$	
MS-ECM-02	0	2,240	0	0	0	-\$273,638	0	0	\$0	0	-\$273,638	\$0

c) Calculation Methodology

Savings are modeled upon switching from Class B to Class A and displacement of Class A coincident peak. Best case is achieving 5/5 peaks or no cost impact for the GA Demand component with the cost benefit based on the lower HOEP rate cost vs Class B rate cost. To be conservative, we have based our calculations on capturing 3.5 out of the 5 GA peaks. Should U of T achieve all 5/5 peaks the savings would be zero and overall savings would be increased.

d) Constructability.

ECM relies on operational commands and no added equipment outside of peak prediction service.



5.7.4 Northwest Chiller Plant (NW)

The following ECMs are being considered for opportunities in addition to the specific building ECMs and focuses on demand management for GA and DR.

NW-ECM-01: Ice Storage System (ISS)

a) Overview

There is an excellent opportunity to install ice storage to offset chiller power during peak summer cooling days. The peak summer cooling days coincide extremely well with the 5CP demand on the Ontario grid. The low purchase price and simplicity of operation make this an attractive candidate for additional demand response.

Each installation is intended to provide 3 hours of block cooling by slowly melting the ice tanks, the tanks are then re-frozen with a dedicated ice chiller steadily loaded over an 18-hour off-peak period.

Scope of Work

- Supply and install an equivalent Trane dual temp CVHF900 chiller
Supply and an equivalent Trane ice making system capable of displacing 2500-Tons at 3 hrs or 6,750 ton-hrs.
The following table summarizes the number of tanks for either a 2- or 3-hour load shift.

Table with 3 columns: Item, NW, Units/Notes. Rows include Peak Electrical Cooling Load (2,500 Tons), Number of Hours to Load Shift (3 Hours), Diversity (0.9), Load Shift (Ton-Hrs) (6,750 Ton-Hours), Number of 1500C Modules (21), Number of Hours to Load Shift (2), Load Shift (Ton-Hrs) (4,500 Ton-Hours), and Number of 1500C Modules (14).

Objectives Supported: Build resilient low carbon systems
Principals Applied: Balance carbon with cost, Reach beyond our own assets, Foster innovative solutions

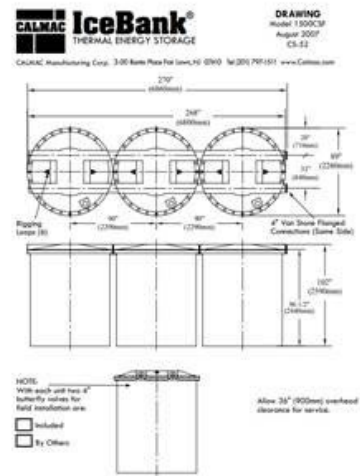

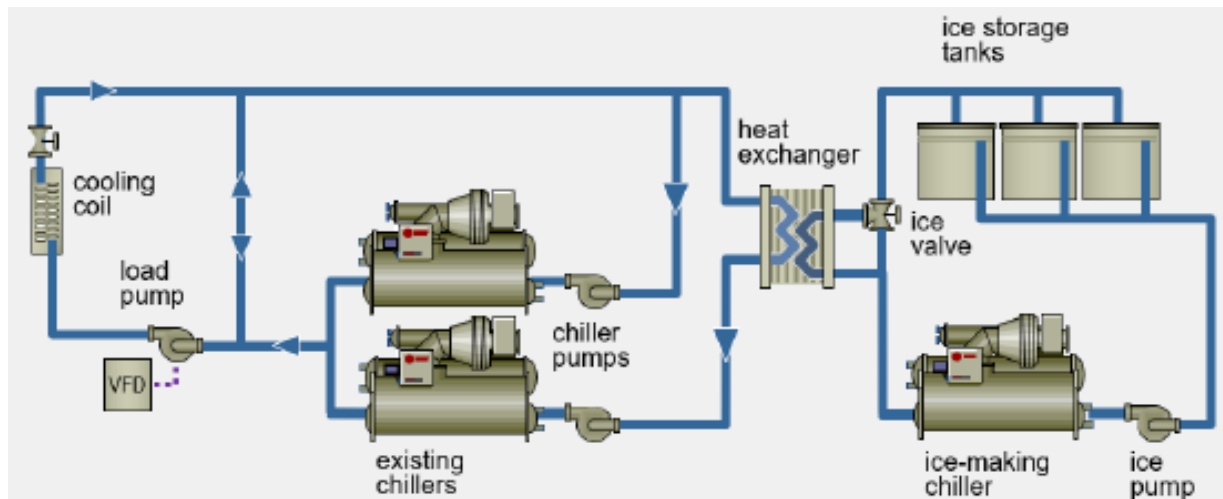

Figure 32: Proposed Ice Storage Schematic

b) Economics and Other Benefits

We have included savings for demand management but not additional operational costs. We do expect to add operational costs for the increase differential cost of operation that will be detailed at the next stage of development.

ECM ID	Electrical Savings						Thermal Savings			Saving Totals		Cost Est w/o TPC
	kW ^{DR}	kW ^{GA}	kW ^{pk}	kWh	tCO _{2e}	\$	MMBtu	tCO _{2e}	\$	tCO _{2e}	\$	
NW-ECM-01	2,000	2,000	0	0	0	-\$144,320	0	0	\$0	0	-\$144,320	\$4,662,880

c) Calculation Methodology

Preliminary sizing and savings provided by Trane. Savings are modeled upon switching from Class B to Class A and displacement of Class A coincident peak. Best case is achieving 5/5 peaks or no cost impact for the GA Demand component with the cost benefit based on the lower HOEP rate cost vs Class B rate cost. To be conservative, we have based our calculations on capturing 3.5 out of the 5 GA peaks. Should U of T achieve all 5/5 peaks the savings would be zero and overall savings would be increased.

d) Constructability

The equipment siting has not been finalized. There is plenty of space inside the Mechanical Room and where we are proposing to install the ISS.



NW-ECM-02: Battery Energy Storage System (BESS)

a) Overview

To further enable demand response and GA avoidance 6MWh hours of battery storage will be installed in the central heating plant. The batteries will be purchased in a self-contained unit and installed in a stacked manner near the electrical infrastructure. The 6MWh of capacity will provide 2MW of demand response capacity.

There are multiple benefits to the battery storage systems as they can be charged overnight when electricity is both cheap and clean with a lower carbon content than the marginal during daytime operation. The conversion efficiency of the batteries is also very high at over 90%. Containerized solutions provide an advantage for noise mitigation and the ability to relocate generator in future to accommodate relocation of the Central Plant and/or Nodal Plant Design.

Objectives Supported

- Build resilient low carbon systems

Principals Applied

- Balance carbon with cost
- Reach beyond our own assets
- Foster innovative solutions

Scope of Work:

Supply a containerized BESS solution 2MW @ 3 hours (6MWh) batteries with required HVAC, controls, etc.

b) Economics and Other Benefits

Savings are based on the demand management only. We will need to add in costs for operation and equipment renewal over the life of the project.

ECM ID	Electrical Savings						Thermal Savings			Saving Totals		Cost Est w/o TPC
	kW ^{DR}	kW ^{GA}	kW ^{Pk}	kWh	tCO2e	\$	MMBtu	tCO2e	\$	tCO2e	\$	
NW-ECM-02	1,500	1,600	0	0	0	-\$120,456	0	0	\$0	0	-\$120,456	\$4,024,879

c) Calculation Methodology

Savings are modeled upon switching from Class B to Class A and displacement of Class A coincident peak. Best case is achieving 5/5 peaks or no cost impact for the GA Demand component with the cost benefit based on the lower HOEP rate cost vs Class B rate cost. To be conservative, we have based our calculations on capturing 3.5 out of the 5 GA peaks. Should U of T achieve all 5/5 peaks the savings would be zero and overall savings would be increased.



d) Constructability

The equipment siting has not been finalized. There is space around the site. We have assumed a typical installation and close to an electrical connection with no added structural work or the like. Since these are based on containerized solution they can be relocated to suit.

5.7.5 Varsity (VA)

The following ECMs are being considered for opportunities in addition to the specific building ECMs and focuses on demand management for GA and DR.

VA-ECM-01: Battery Energy Storage System (BESS)

a) Overview

To further enable demand response and GA avoidance 6MWh hours of battery storage will be installed in the central heating plant. The batteries will be purchased in a self-contained unit and installed in a stacked manner near the electrical infrastructure. The 6MWh of capacity will provide 2MW of demand response capacity.

There are multiple benefits to the battery storage systems as they can be charged overnight when electricity is both cheap and clean with a lower carbon content than the marginal during daytime operation. The conversion efficiency of the batteries is also very high at over 90%. Containerized solutions provide an advantage for noise mitigation and the ability to relocate generator in future to accommodate relocation of the Central Plant and/or Nodal Plant Design.

Objectives Supported

- Build resilient low carbon systems

Principals Applied

- Balance carbon with cost
- Reach beyond our own assets
- Foster innovative solutions

Scope of Work:

Supply a containerized BESS solution 2MW @ 3 hours (6MWh) batteries with required HVAC, controls, etc.

b) Economics and Other Benefits

Savings are based on the demand management only.

ECM ID	Electrical Savings						Thermal Savings			Saving Totals		Cost Est w/o TPC
	kW ^{DR}	kW ^{GA}	kW ^{PK}	kWh	tCO2e	\$	MMBtu	tCO2e	\$	tCO2e	\$	
VA-ECM-01	1,500	1,600	0	0	0	-\$120,456	0	0	\$0	0	-\$120,456	\$5,477,700



c) Calculation Methodology

Savings are modeled upon switching from Class B to Class A and displacement of Class A coincident peak. Best case is achieving 5/5 peaks or no cost impact for the GA Demand component with the cost benefit based on the lower HOEP rate cost vs Class B rate cost. To be conservative, we have based our calculations on capturing 3.5 out of the 5 GA peaks. Should U of T achieve all 5/5 peaks the savings would be zero and overall savings would be increased.

d) Constructability

The equipment siting has not been finalized. There is space around the site. We have assumed a typical installation and close to an electrical connection with no added structural work or the like. Since these are based on containerized solution they can be relocated to suit.



Interim Progress Report
for University of Toronto

Project LEAP - Detailed
Study Phase

March 2023

PIVOT



Interim Progress Report for University of Toronto
Project LEAP - Detailed Study Phase

March 2023

Table of Contents

1	Executive Summary	1
2	Proposed Improvements Scope Matrix	3
3	Key Performance Indicators	10
4	Updated Project Schedule	11
Appendix A	Updated Project Assumptions Log	

1 Executive Summary

The University of Toronto's (U of T) bold and ambitious Project LEAP demands a different kind of thinking, and we have responded. It is with great pleasure that MCW Custom Energy Solutions and Ecosystem Energy Services combined forces to form PIVOT (Project LEAP Integrated Vision of Outcomes & Technologies), as partners to U of T in the delivery of Project LEAP.

PIVOT embarked on the Detailed Study, under the direction of a Letter of Award, on December 16th, 2022 with the expectation of completion by March 31st, 2023. PIVOT is pleased to present U of T the enclosed Detailed Study Summary with the expectation that the complete Detailed Study draft will be submitted by April 14th, 2023.

Activity Highlights

Through numerous meetings and open conversations, PIVOT and U of T have established a strong and productive collaboration. By sharing knowledge and maintaining continuous feedback, the routine and unscheduled meetings served to develop concepts and designs, identify potential roadblocks, and find solutions to achieve Project LEAP's ambitious GHG emissions reductions and energy saving goals.

Important improvements that form the scope of Project LEAP include:

- HVAC air-side and HVAC water-side heat recovery in Project LEAP's Core Buildings (MSB, CCBR, LDP, McCaul Cluster) to support expanded low-carbon heating strategies at both the nodal and central distribution level.
- Additional conservation-first strategies in Lighting, Controls, and Domestic Water systems contributed to the progress achieved by Project LEAP.

Since December, we have worked together to fully understand U of T needs in terms of project outcomes and asset renewal needs to maximize project alignment with the original objectives and KPIs. In addition to the measures submitted under the Preliminary Study, the Project LEAP Detailed Study integrated several notable scope additions and developments, specifically:

1. Integration of the Landmark Project within Project LEAP to accelerate energy savings and carbon emission reductions.
2. Expanded strategy to maximize hydronic heat sinks on the repurposed Sofame network and high temperature hot water network to reduce demand for steam.
3. Increased heat recovery within the buildings of the MSB chilled water network to create a low carbon heat source.
4. Increased capacity of gas turbine generator at CSP

Integration of Landmark Project into Project LEAP Low-carbon Thermal Energy Exchange System

The integration of the Landmark project into the Project LEAP will ensure a consistent approach with the U of T long term carbon reduction plan. More specifically, the integration will:

- Save costs to U of T by avoiding the installation of the heat pump systems originally designed for Landmark;
- Increase the condenser water temperature (155F rather than 135F as currently designed), enabling to integrate more heat loads than originally planned with Landmark (sinks);
- Maximize the potential of the geothermal field by using low temperature heat pump (28F), allowing to maximize the heat extraction from the ground (maximizing asset);
- Add heat recovery on the MSB exhausts, maximizing the heat harvest on this asset;
- Increase the combined efficiency of Stage 1 and Stage 2 heat pumps by using 1 machine instead of cascading 2 heat pumps;
- Facilitate the operation and maintenance by centralizing all the heat pumps into one location;
- Provide a minimum of additional cooling capacity to MSB;
- Enable the utilization of the geothermal system for free cooling during the spring/summer. In addition, Pivot will investigate integrating the geothermal field as a demand response asset;
- Recharge the geothermal field, by discharging heat into the ground that would otherwise be dumped into the cooling towers. This heat will then be reused for heating during fall/winter operation; and
- Leave the heat recovery charges assets on the West available, enabling further GHG reduction in the future.

Global Adjustment and Demand Response Strategies

PIVOT developed a combination of demand response strategies in an effort to balance the challenges and opportunities of U of T's unique settings. The strategies were developed to maximize peak electrical demand cost avoidance while maximizing Project LEAP's core GHG emissions reductions mandate.

The holistic solution proposed by PIVOT includes:

- Installation of a new 10 MW gas turbine.
- Overhaul of the existing 5 MW gas turbine.
- Replacement of 2 x 0.25 kW steam turbines.
- Integration of the existing steam driven chiller.
- Implementation of 4 MW of clamps

Moving forward

In the past 15 weeks, PIVOT and U of T collaborated closely to further refine the desired outcomes of Project LEAP. We are confident the project has crystalized into a transformational solution for energy management at U of T's St. George Campus. PIVOT stands behind our concept for the project as the optimal path forward for U of T.

The PIVOT team is proud of the work accomplished together in developing Project LEAP thus far. PIVOT looks forward to progressing together with U of T's project stakeholders, and to delivering bold results for U of T through Project LEAP.

2 Proposed Improvements Scope Matrix

PIVOT has created a tabular summary Scope Matrix for Project LEAP. This matrix is structured to provide U of T with a concise summary of Improvements outlined in our Preliminary Study, and how those Improvements currently stand in terms of technical Changes, with consideration of Mandatory Requirements, if applicable.

Scope Matrix Table Legend:	N = New
	S = Stays
	C = Changed
	R = Removed

Building		Measure Name	Improvement (Dec 2022 Proposal)	Mandatory from RFP	Final KPI (2023-03-31) (Changes relative to Dec 2022 Proposal)
CSP	S	CSP-01: Electric Steam Boilers	Removal of the Boiler #4. Infill structural platform level 2. Repair slab level 1.	Removal of gas fired steam Boiler #4 (125,000 lbs/hr @200psi) and replacement with, more than one of equal or greater, total capacity electric boilers.	
	C		New electric steam boilers (2x 18MW). Automatic BD as per MR.	Install an automatic continuous blowdown system on any new steam boilers in Central Steam Plant.	New electric steam boilers (2 x 15MW).
	C	CSP-02: Heat Pumps	New 2nd Stage heat pump (1x 1,000 tons). Source for upgraded LTHW network and 3rd stage HP in CSP.		Changed: 2nd stage HP moved to Landmark
	C		Connect new CSP 2nd stage heat pump to the BCIT chilled water network (source from campus loads and new heat recovery measures)		Changed: 2nd stage HP moved to Landmark. Connect BCIT Cooling return for inlet cooling to GTG measure.
	C		New 3rd stage high temperature heat pumps (7 MW total capacity) for upgraded HTHW network.		Changed: Capacity of 4 MW.
	S		HTHW network optimization (reduced temperature) to allow the use of a heat pump. Heat exchangers in connected buildings may be upgraded.		HTHW Temperature Optimization Testing Completed by PIVOT. Test result: The bypass at the building level were closed. We were able to lower the return temperature to 190°F. It was not possible to lower it more due to condensate return constraint. The project will fix that issue and we will improve the return temperature further.
	C		Repurpose distribution network to increase year around operation temperate to allow		Changed: LTHW network expansion (new connection to Landmark, CCBR,

Building		Measure Name	Improvement (Dec 2022 Proposal)	Mandatory from RFP	Final KPI (2023-03-31) (Changes relative to Dec 2022 Proposal)
			optimal heat transfer to connected building for HTHW network		FG, LDP). New stage 2 HRC in Landmark (3x 800 tons).
	C		Connect chilled water to the Sofame flue gas heat recovery system to stage 2 heat pump in CSP		Changed: Connect Sofame to LTHW return (as source)
	S	CSP-03: GTG	New GTG to offset GA event (1x 10MW)		
	R	CSP-04: BESS	New BESS to offset GA event (5 MW - 10 MWh)		Removed
	S	CSP-05: EMRS Demand Reduction	Engineered DR protocols programmed on EMRS. Clamps 1 and 2		Proposed Clamp capacity at 4 MW
	R	CSP-06: Mandatory Requirements	Replace HTHW pumps. Add VFD drive (x1, other x2 have)	In Central Steam Plant, remove and replace 3 x 50hp high temperature hot water recirculation pumps and install VSD.	Removed
	R		Air compressor system upgrades	Replace 75hp city water cooled Quincy air compressor in Central Steam Plant.	Removed
	R		Resolve steam header system single point of failure. Steam header modifications	Resolve the single point of failure on the main steam header as indicated in Arup's Site Utility Master Plan Report.	Removed
	R		Replace aged blowdown tank, flash tank and condensate tank # 2 in Central Steam Plant.	Replace aged blowdown tank, flash tank and condensate tank # 2 in Central Steam Plant.	Removed
	R		Reserve space for CERT. Level 3 opening where B#4 was prior. Provide 60kW electrical service.	Provide a floor space of 20'W x 30'L x 12'H in CSP for U of T's academic team to install the Carbon Electro catalytic Recycling Toronto (CERT) equipment in the Central Plant. <ul style="list-style-type: none"> •The CERT system utilizes the CO2 from the boiler exhaust, water and solar powered electricity to produce ethylene feedstocks – the raw material used to create petrochemicals. •Highest space location is preferred in vacancy created by boiler # 4 removal in close proximity to boiler stack. •Provide 60kW electrical service. 	Removed
	R				

Building		Measure Name	Improvement (Dec 2022 Proposal)	Mandatory from RFP	Final KPI (2023-03-31) (Changes relative to Dec 2022 Proposal)
	R		New MCCs for new and upgraded equipment.	The existing MCC's are past expected life. Provide new MCC's for all new and upgraded equipment. Provide a new feeder from the existing breaker in the switchboard, to accommodate both the new MCC section and existing MCC in Central Steam Plant	Removed
	R		Install VSD drives on 2 x 30hp condensate transfer pumps to deaerator and configure the control sequence to control deaerator level with pump speed and in bypass with control valve.	Install VSD drives on 2 x 30hp condensate transfer pumps to deaerator and configure the control sequence to control deaerator level with pump speed and in bypass with control valve.	Removed
	R		Upgrade control room air conditioning system and install air conditioning in water testing lab	Upgrade control room air conditioning system and install air conditioning in water testing lab	Removed
	C	CSP-07: Existing 6MW GTG	Utilize existing 6 MW GTG as a GA asset		Changed: New generator Core engine replacement Air intake cooling
	C	CSP-08: STG			Changed: 2 new 0,25 kW steam turbines, reuse existing generators and misc
BCIT	R	BCIT-01: HVAC – Water-side	Add a HRC to collect wasted heat from the building exhaust		Removed: Not required because of change to use Landmark and MSB HR
	R		Add heat exchanger to collect wasted heat from the IT server		Removed. Not required because of change to use Landmark and MSB HR
MSB	R	MSB-01: HVAC – Water-side	Replace an obsolete chiller with a new 1000 Tons heat pump connected to the low temperature network and the cooling tower offering a good operation flexibility	Remove and replace the MSB Chiller #1 (2561 Ton), #6 (450 Ton) and #7 (401Ton) from the deferred maintenance liability. ▪ Chillers to have sufficient turn down ratio to satisfy year round - including low load operation ▪ Chillers to be in alignment with Arup's Site Utility Master Plan (Node 5 design).	Changed: See Landmark. Planning to install 2400 T available to feed MSB
	R		Addition of a 600 tons chiller offering 3 configurations of operation: building cooling,		Changed: See Landmark.

Building		Measure Name	Improvement (Dec 2022 Proposal)	Mandatory from RFP	Final KPI (2023-03-31) (Changes relative to Dec 2022 Proposal)
			heat recovery from lab exhaust in CCBR, and ice making to offset GA		
	R		Addition of heat exchangers to decouple in building chilled water from the central chilled water network for better resiliency in case of in building issues		Changed: Adding HEX for NMR
	C				2X8" from chiller room to 9th floor LT piping
	R	MSB-02: Ice Storage	Addition of new thermal storage media for demand response, charged by new heat recovery chiller		Removed
	R	MSB-03: Mandatory Requirements	Compressed air compressor replacement (right sized)	In MSB, replacement of 2 backup air compressors, addition of compressed airflow meters to all buildings fed off the central loop and integration with EMRS.	Removed
	R		Chilled water loop decoupling through introduction of new heat exchangers for better resiliency in case of in-building issues, and to optimize pumping energy	Decouple the MSB & NW Chilled water loops from all the buildings with HXs and add/upgrade associated pumps. <ul style="list-style-type: none"> At MSB, include for provision of separate HX loop for NMR process load Provide a high level estimate (Class D) based on a drawing review and assuming adequate equipment space is available Provide a separate itemized cost for this item. Cost not to be included in NPV calculation. 	Removed by UoT
	N	MSB-04: HVAC – Air-side			5 HR coil in exhaust connected to chilled water on the 9th floor
NW CP	R	NCP-01: Mandatory Asset Renewal	Replace obsolete chiller by a new one Addition of heat exchangers to decouple in building chilled water from the central chilled water network for better resiliency in case of in-building issues	Remove and replace Chiller #2 1200 ton York Chiller with chiller that has sufficient turn down ratio to satisfy existing seasonal and future year round with part load operation and in alignment Arup's Site Utility Master Plan (Node 1 design).	Removed by UoT
ESB	R	ESB-01: Lighting	Completion of migration to LED Lighting in the building through targeted retrofits in remaining non-LED fixtures		Removed

Building		Measure Name	Improvement (Dec 2022 Proposal)	Mandatory from RFP	Final KPI (2023-03-31) (Changes relative to Dec 2022 Proposal)
	R	ESB-02: HVAC – Air-side	Deep energy retrofit solution to building air-side HVAC systems that comprises laboratory VAV system upgrades and strobic fan VSD		Removed
	C	ESB-03: HVAC – Water-side	Replacement of heating coil to allow better heat transfer with Low temperature network		Addition: Adding HEX
	R		Add a HRC to collect wasted heat from the new lab exhaust		Removed
	R		Addition of solar thermal panel to provide clean energy	Include renewable ECMS (Solar PV, Solar Thermal, Geo, etc.)	Removed
	R	ESB-04: BAS & EMRS	New BAS, compatible with U of T Standard & ready for EMRS integration	Upgrade Building Automation System with Fault Detection and Diagnostic (FDD) capability, and integrate to EMRS. For details refer to Building Automation System Addendum.	Removed
	R	ESB-05: Water	Strategic domestic water conservation through low-flow fixture retrofits and steam sterilizer unit cooling reservoir retrofits		Removed
CCBR	S	CCBR-01: Lighting	Completion of migration to LED lighting		
	S	CCBR-02: HVAC – Air-side	Laboratory VAV system upgrades		
	S	CCBR-03: HVAC – Water-side	Addition of the CCBR building to the LTHW network		
	S	CCBR-04: BAS & EMRS	New BAS, compatible with U of T Standard & ready for EMRS integration	Upgrade Building Automation System with Fault Detection and Diagnostic (FDD) capability, and integrate to EMRS. For details refer to Building Automation System Addendum.	
	S				
	R	CCBR-05: BESS	New BESS of 1.8 MW for 2 hours to offset GA event		Removed
S	CCBR-06: Water	Water conservation through low-flow fixture retrofits and steam sterilizer unit cooling reservoir retrofits			
LDP	S	LDP-01: HVAC – Air-side	Laboratory VAV system upgrades		
	C	LDP-02: HVAC – Water-side	Add a HRC to collect wasted heat from the building exhaust, reject heat in preheat coil, radiant and terminal reheat system.		Changed: LD connected to central distribution and Landmark
	N	LDP			New: Installing 2 x 4" of LTHW risers to penthouse
	S	LDP-03: BAS & EMRS	New BAS, compatible with U of T Standard & ready for EMRS integration	Upgrade Building Automation System with Fault Detection and	

Building		Measure Name	Improvement (Dec 2022 Proposal)	Mandatory from RFP	Final KPI (2023-03-31) (Changes relative to Dec 2022 Proposal)
				Diagnostic (FDD) capability, and integrate to EMRS. For details refer to Building Automation System Addendum.	
	S	LDP-04: Water	Strategic domestic water conservation through low-flow fixture retrofits and steam sterilizer unit cooling reservoir retrofits		
MC	S	MC-01: Lighting	Completion of migration to LED lighting		
	S	MC-02: HVAC – Air-side	Addition of a heat recovery wheel on the fresh air of HS		
	S	MC-03: HVAC – Water-side	Disconnect EC, OA, HS from Enwave steam	Disconnect from third party district steam for all buildings before November 2027 and provide acceptable alternate solution.	
	S		Replace existing chiller by a new chiller	Removal of the existing 500T chiller and replacement with required cooling capacity	
	S		Addition of a heat pump with dual operation, heating in winter and cooling in summer		
	S		Conversion from steam to hot water of the heating system		
	S		Addition of 3 natural gas boilers for resiliency		
	S		Electrification of domestic hot water production		
	S		Addition of heat recovery load: IT server and flue gas heat recovery		
	C		Addition of solar thermal panel to provide clean energy	Include renewable ECMS (Solar PV, Solar Thermal, Geo, etc.)	Include 120 kW of solar PV
	R	MC-04: BAS & EMRS	Control upgrade for ES, OA and HS, EMRS integration ready	Upgrade Building Automation System with Fault Detection and Diagnostic (FDD) capability, and integrate to EMRS. For details refer to Building Automation System Addendum.	Removed
	R	MC-05: Water	Retrofit and replacement fixtures to migrate to low flow		Removed
	S	MC-07: Domestic Hot Water	New electric hot water heaters to replace existing natural gas & steam sourced heaters	Convert Gas DHW to electric	
R	MC-08: Mandatory Requirements: Electrical	Main service breakers/switches to be updated with arc flash safety requirements as per the electrical design standard and shall consist of: <ul style="list-style-type: none"> An arc flash maintenance switch(es) Remote OPEN/CLOSE of breaker outside of electrical rooms or arc flash boundary 	Main service breakers/switches to be updated with arc flash safety requirements as per the electrical design standard and shall consist of:	Removed	

Building		Measure Name	Improvement (Dec 2022 Proposal)	Mandatory from RFP	Final KPI (2023-03-31) (Changes relative to Dec 2022 Proposal)
			<ul style="list-style-type: none"> Remote Racking IN/OUT outside of electrical rooms or arc flash boundary 	<ul style="list-style-type: none"> An arc flash maintenance switch(es) Remote OPEN/CLOSE of breaker outside of electrical rooms or arc flash boundary Remote Racking IN/OUT outside of electrical rooms or arc flash boundary 	
LK	N	LK-01: HVAC – Water-side			<p>New: Install 3 CYK (combined stage 1 and 2) Total capacity of 2400T Producing 28F on evap and 155F on condenser. CYKs to be connected on the existing geothermal field to be used as source (winter) and sink (summer). Chillers + geo available for free cooling to provide up to +2000T cooling to MSB during spring and summer. Connected to MSB, LS, FG, CCBR through new LT + CH piping distribution.</p>
LM	N	LM-01: HVAC - Water-side			<p>New: Increase heat exchanger, shifting load from HT to LT.</p>

3 Key Performance Indicators

PIVOT developed Project LEAP with an outcomes-based approach, where outcomes are defined as successfully meeting the GHG emissions reductions while optimizing the OPEX savings. The following summary table presents the detailed study results:

Key Performance Indicator	Detailed Study– March 31, 2023
First Year OPEX Savings*	\$3,000,000
Total Scope 1 GHG Emissions Reduction (Tonnes eCO2)	54,500
First Year Carbon Tax Savings	\$6,500,000
Net GHG Emissions Reduction (Tonnes eCO2)	48,300
Total First Year Savings (\$)	\$9,500,000
Study Cost (\$)	\$2,700,000
Project Cost (\$) – inclusive of Study Cost above**	\$146,000,000
Simple Payback (years)	15

The KPIs are based on the assumptions presented in Appendix A.

4 Updated Project Schedule

Project LEAP - Detailed Study Schedule 03/31/2023		2023												2024												2025												2026												2027												2028													
		J	F	M	A	M	J	J	A	S	O	N	D	J	F	M	A	M	J	J	A	S	O	N	D	J	F	M	A	M	J	J	A	S	O	N	D	J	F	M	A	M	J	J	A	S	O	N	D	J	F	M	A	M	J	J	A	S	O	N	D	J	F	M	A	M	J	J	A	S	O	N	D	J	F
Contractual																																																																											
U of T Governance Approval Signed Contract Implementation Substantial Performance Start Up Period Performance Period					█																																																																						
					█																																																																						
														█												█																																																	
																										█												█																																					
																																						█																																					
																																						█																																					
																																						█																																					
Engineering																																																																											
Eng Detailed Study Detailed Study Review / Collaboration Drawings Permits		█																																																																									
				█																																																																							
						█																																																																					
						█																																																																					
Long-lead time Procurement																																																																											
Equipment / electrical gear													█												█																																																		
Buildings implementation																																																																											
CSP CSP-01 : Electric Boiler CSP-02 : HTHP CSP-03 : GTG2 CIA submission/approval CCE submission/approval CCA submission/approval CSP-05: EMRS DR CSP-07 : Existing GTG1 CSP-08 : STG																										█												█																																					
																										█												█																																					
				█																																																																							
				█																																																																							
				█																																																																							
				█																																																																							
				█																																																																							
				█																																																																							
MSB MSB-01: HVAC – Water-side MSB-02: HVAC – Air-side																										█												█																																					
																										█												█																																					
ESB ESB-01: HVAC – Water-side																									█																																																		
CCBR CCBR-01: Lighting CCBR-02: HVAC – Air-side CCBR-03: HVAC – Water-side CCBR-04: BAS & EMRS CCBR-06: Water																										█																																																	
																										█																																																	
				█																																																																							
				█																																																																							
				█																																																																							

Project LEAP - Detailed Study Schedule 03/31/2023		2023												2024												2025												2026												2027												2028													
		J	F	M	A	M	J	J	A	S	O	N	D	J	F	M	A	M	J	J	A	S	O	N	D	J	F	M	A	M	J	J	A	S	O	N	D	J	F	M	A	M	J	J	A	S	O	N	D	J	F	M	A	M	J	J	A	S	O	N	D	J	F	M	A	M	J	J	A	S	O	N	D	J	F
LDP	LDP-01: HVAC – Air-side																																																																										
	LDP-02: HVAC – Water-side																																																																										
	LDP-03: BAS & EMRS																																																																										
	LDP-04: Water																																																																										
MC	MC-01: Lighting																																																																										
	MC-02: HVAC – Air-side																																																																										
	MC-03: HVAC – Water-side																																																																										
	MC-06 : Domestic Hot Water																																																																										
LM	LM-01 : HVAC Water side																																																																										
LMK	LMK-01 : HVAC Water side																																																																										
LT	LT-01 HVAC Water side																																																																										