

**FOR RECOMMENDATION**

**PUBLIC**

**OPEN SESSION**

**TO:** Planning & Budget Committee

**SPONSOR:** Scott Mabury, Vice President, Operations and Real Estate Partnerships

**CONTACT INFO:** 416-978-2031, [scott.mabury@utoronto.ca](mailto:scott.mabury@utoronto.ca)

**PRESENTER:** Gilbert Delgado, Chief, University Planning, Design and Construction  
Christine Burke, Director, Campus and Facilities Planning

**CONTACT INFO:** 416-978-2011, [gilbert.delgado@utoronto.ca](mailto:gilbert.delgado@utoronto.ca)  
416-978-4333, [christine.e.burke@utoronto.ca](mailto:christine.e.burke@utoronto.ca)

**DATE:** September 5, 2019 for September 17, 2019

**AGENDA ITEM:** 5(b)

**ITEM IDENTIFICATION:**

Capital Project: *Report of the Project Planning Committee for the Facilities Master Plan at the Koffler Scientific Reserve*

**JURISDICTIONAL INFORMATION:**

Pursuant to section 4.2.3. of the Terms of Reference of the Planning and Budget Committee, "...the Committee considers reports of project planning committees and recommends to the Academic Board approval in principle of projects (i.e. space plan, site, overall cost and sources of funds)."

Under the *Policy on Capital Planning and Capital Projects*, "...Capital projects over \$5 million and up to \$20 million will be considered by the Planning and Budget Committee for projects at the St. George campus and by the respective Campus Affairs Committees and Campus Councils for projects at University of Toronto Mississauga and University of Toronto Scarborough and recommended to the Academic Board for consideration. It is expected that such projects will be placed on the Board's consent agenda and be confirmed by the Executive Committee of the Governing Council. Execution of such projects is approved by the Business Board."

**GOVERNANCE PATH:**

**A. Project Planning Report: Site and Space Plan**

- 1. Planning and Budget [for recommendation] (September 17, 2019)**
- Academic Board [for approval] (October 3 2019)
- Executive Committee [for confirmation] (October 15, 2019)

**B. Execution of the Project:**

- Business Board [for approval] (October 7, 2019)

## **PREVIOUS ACTION TAKEN:**

On April 14, 2016, CaPS Executive Committee approval to engage consultants to develop the project through the schematic design phase and prepare fundraising material was confirmed. Through a subsequent proposal call, Montgomery Sisam, was selected as the project architectural team.

## **HIGHLIGHTS:**

The Koffler Scientific Reserve (KSR) at Jokers Hill on the Oak Ridges Moraine in King Township has developed into a major venue for research and instruction in ecology, environmental biology and related areas of study.

KSR currently serves four types of academic users, each with different needs for teaching and research: (1) Students on intensive, two-week residential field courses, (2) Students using KSR's facilities on day-trips or two-day excursions as part of regular classes, hosted on the three campuses, (3) Researchers, including PI's, post-docs, technicians, and undergraduates who stay in residence during their peak field season, and (4) Researchers who perform day-trips to KSR because of the lack of housing and/or dining accommodations.

In July 2011 a Task Force appointed by the Koffler Scientific Reserve Management Board prepared a KSR Real Estate Strategy which recommended freeing up scarce resources to advance the KSR research and teaching mission. The report included a strategy that would include building one or two multi-purpose use buildings in the area of the arena, south barn, north barn and workshop, and discontinuing the use of several outlying buildings. Future buildings would aim to reflect sustainable materials and design.

In 2017, Montgomery Sisam Architects were selected to design the new Operations Centre for KSR. Schematic design work commenced in fall of 2017, and was completed in February 2018. The proposal was positively reviewed by the Design Review Committee in February 2018. Fundraising material was prepared for the Faculty of Arts & Science. With funding sources in place, approval is being sought to proceed with the full implementation of the project.

The new dining and accommodations facilities at KSR will transform the property and educational, research, and teaching experience by providing a centralized location for meeting, dining, teaching, and housing. By facilitating group dining experiences, large meeting places for research seminars and classes, and individualized housing for researchers, students, faculty, and visitors, the new facility will offer: flexibility; private accommodations; shared social, dining, and learning spaces; and a field research and teaching experience that is currently unavailable at KSR or on the campuses. As an environmental research centre, the Koffler Reserve expects this project will be an exemplar in sustainable design and green construction. The design is targeting carbon neutral. Input from student representatives on the project planning committee, specifically regarding accommodation within the new facility, significantly affected the direction of the project. The original intent was to construct a single building, with dorm-type accommodation inside. These students, with their experience from other field research stations, advocated for the bunkies/camp-style facilities that

were more in keeping with the quintessential research station experience, and better suited for those researching on site for an extended period of time.

Rezoning of the property to allow the construction of this facility was completed in 2018. Site Plan approval will be required.

## **Secondary Effects**

The South Barn, North Barn and Hospitality Barn will be demolished. The Arena Barn will be retained and used for workshop and storage space. The out building to the south will be demolished. There are two septic tanks serving these barns. As part of the demolition of these buildings, the existing septic systems will also be removed.

Research and teaching on the Reserve is expected to continue throughout construction. The Hospitality Barn operates as a reception/arrival point for visitors and students to the Reserve. The Station Manager also works out of this building. During construction, faculty, students and visitors will need to be directed elsewhere, likely toward the laboratory, further back within the Reserve. The Station Manager's office will need to be relocated as well.

The current housing will remain in place and operational, allowing for the Reserve to function as normal. There are materials stored in the barns slated for demolition, and this material must either be disposed of or relocated. A transportation/access plan will need to be in place during construction which may require the temporary closure of one of the two driveways.

## **Schedule**

The proposed schedule for the project is as follows:

- April 14, 2016            Approval by CaPS Executive for Interim Project Planning Report and expenditure of consultant services
- June 2017                Consultant Team selection
- February 2018         Schematic Design Complete
- August 30, 2019        Approval by CaPS Executive for additional expenditure of consultant fees through Design Development
- September 2019        Design Development
- October 24, 2019        Governing Council, Cycle 1 2019-20
- November 2019        Construction Documents
- Spring 2020             Tender and Award
- Spring/Summer 2020    Estimated Construction Start
- Summer 2021            Occupancy

**FINANCIAL AND PLANNING IMPLICATIONS:**

Discussion of overall costs and sources of funds can be found in the *in camera* document for this project.

**RECOMMENDATION:**

Be It Recommended:

THAT the *Project Planning Committee Report for Facilities Master Plan at Koffler Scientific Reserve*, dated August 30, 2019, be approved in principle; and,

THAT the project totalling 903 net assignable square metres (nasm) (1,445 gross square metres (gsm)), be approved in principle, to be funded by the Faculty of Arts Building Fund and Future Major Capital Project Reserves.

**DOCUMENTATION PROVIDED:**

- *Report of the Project Planning Committee for Facilities Master Plan at Koffler Scientific Reserve*, dated August 30, 2019.

Report of the Project Planning Committee for  
**Facilities Master Plan at the Koffler Scientific Reserve**

August 30, 2019

## Table of Contents

I. EXECUTIVE SUMMARY .....	3
II. PROJECT BACKGROUND .....	4
a) <i>Membership</i>	
b) <i>Terms of Reference</i>	
c) <i>Background Information</i>	
d) <i>Statement of Academic Plan</i>	
e) <i>Space Requirements</i>	
III. PROJECT DESCRIPTION .....	9
a) <i>Vision Statement</i>	
b) <i>Space Program and Functional Plan</i>	
Space Program	
c) <i>Building Considerations</i>	
Standards of construction	
Building characteristics and massing	
Mechanical/ Electrical and Data	
Accessibility	
Personal safety and security	
Servicing (including garbage and recycling, deliveries)	
Elevators	
Acoustics	
Signage and donor recognition	
Sustainability design and energy conservation	
Environmental Health and Safety	
d) <i>Site Considerations</i>	
Site context	
Master Plan	
Zoning regulations	
Landscape and open space requirements	
Site access	
Heritage status	
Wayfinding	
Soil conditions	
Demolition of existing structures	
Site servicing; existing and proposed	
Environmental issues, regional conservation, Ministry of the Environment	<b>Error!</b>
<b>Bookmark not defined.</b>	
e) <i>Campus Infrastructure Considerations</i>	

Utilities (electrical, water)  
Sewer and storm water management  
Communications (phone/data)  
Roads and pedestrian pathways  
Servicing and fire access

- f) Secondary Effects*
- g) Schedule*

IV. RESOURCE IMPLICATIONS ..... 22

- a) Total Project Cost Estimate*
- b) Operating Costs*
- c) Other Related Costs*
- d) Funding Sources*

V. RECOMMENDATIONS..... 22

## **I EXECUTIVE SUMMARY**

The Koffler Scientific Reserve (KSR) at Jokers Hill on the Oak Ridges Moraine in King Township is quickly developing into a major venue for research and instruction in ecology, environmental biology and related areas of study.

KSR currently serves four types of academic users, each with different needs for teaching and research: (1) Students on intensive, two-week residential field courses, (2) Students using KSR's facilities on day-trips or two-day excursions as part of regular classes, hosted on the three campuses, (3) Researchers, including PI's, post-docs, technicians, and undergraduates who stay in residence during their peak field season, and (4) Researchers who perform day-trips to KSR because of the lack of housing and/or dining accommodations.

Research usage of KSR is voluntary, and largely driven by the needs of faculty for accessible, affordable field sites. KSR is unique in providing a space for large-scale manipulative experiments to test fundamental mechanisms in ecology and evolutionary biology, as well as sites for long-term study that are unlikely to be developed. Research at KSR spans all three campuses, the ROM, and undergraduate units as diverse as EEB, CSB, the Dept. of Biology (UTM), Dept. of Biological Sciences (UTSc), Chemistry, Archaeology, Geography, and University of Toronto Institute for Aerospace Studies.

In July 2011 a Task Force appointed by the Koffler Scientific Reserve Management Board prepared a KSR Real Estate Strategy which recommended freeing up scarce resources to advance the KSR research and teaching mission. The report included a strategy that would include building one or two multi-purpose use buildings in the area of the arena, south barn, north barn and workshop, and discontinuing the use of several outlying buildings. Future buildings would aim to reflect sustainable materials and design.

In 2017, Montgomery Sisam Architects were selected to design the new Operations Centre for KSR. Schematic design work commenced in fall of 2017, and was completed in February 2018. The proposal was positively reviewed by the Design Review Committee in February 2018. Fundraising material was prepared for the Faculty of Arts & Science. With funding sources in place, approval is being sought to proceed with the full implementation of the project.

The new dining and accommodations facilities at KSR will transform the property and educational, research, and teaching experience by providing a centralized location for meeting, dining, teaching, and housing. By facilitating group dining experiences, large meeting places for research seminars and classes, and individualized housing for researchers, students, faculty, and visitors, the new facility will offer: flexibility; private accommodations; shared social, dining, and learning spaces; and a field research and teaching experience that is currently unavailable at KSR or on the campuses. As an environmental research centre, the Koffler Reserve expects this project will be an exemplar in sustainable design and green construction. The design is targeting carbon neutral.

Input from student representatives on the project planning committee, specifically regarding accommodation within the new facility, significantly affected the direction of the project. The original intent was to construct a single building, with dorm-type accommodation inside. These students, with their experience from other field research stations, advocated for the bunkies/camp-style facilities that were more in keeping with the quintessential research station experience, and better suited for those researching on site for an extended period of time.

Rezoning of the property to allow the construction of this facility was completed in 2018. Site Plan approval will be required.



## **II PROJECT BACKGROUND**

### **a) Membership**

Jay Pratt, Vice-Dean Infrastructure & Research, Committee Chair  
John Stinchcombe, Department of Ecology & Evolutionary Biology & Director, KSR  
Stephan Schneider, Station Manager, KSR  
Locke Rowe, Professor, Department of Ecology & Evolutionary Biology  
Marc Cadotte, Assistant Professor, Department of Biological Sciences, UTSC  
Mark Fitzpatrick, Assistant Professor, Department of Biological Sciences, UTSC  
Sean Thomas, Professor, Faculty of Forestry  
Peter Kotanen, Associate Professor, Department of Biology, UTM  
Shannon McCauley, Assistant Professor, Department of Biology, UTM  
Teresa Tuft, Undergraduate Student, Department of Ecology & Evolutionary Biology  
Celina Baines, PhD Student, Department of Ecology & Evolutionary Biology  
Kim McLean, Chief Administrative Officer, Faculty Arts & Science  
Adrienne De Francesco, Executive Director, Project Management  
Lucy Chung, Director of Infrastructure Planning, FAS  
\*Ron Saporta, Assistant Vice-President, Facilities & Services  
Christine Burke, Director, Campus & Facilities Planning  
\*Costas Catsaros, Director, Project Development  
Lisa Neidrauer, Senior Planner, Campus & Facilities Planning

\* Replacement member 2019

### **b) Terms of Reference**

Make recommendations for a comprehensive long term facilities master plan including a detailed space program to allow the Koffler Scientific Reserve to meet core research and education priorities.

Demonstrate that the proposed space program will take into account the Council of Ontario Universities' and the University's own Space Standards.

Determine the secondary effects of the project as well as the requirements for site security, signage and fencing.

Determine a total project cost (TPC) estimate for the project, including costs of implementation in phases if required, and costs associated with secondary effects.

Identify all sources of funding for the capital project, or phases of the project, and anticipated increased operating costs once the project is complete.

### c) **Background Information**

The Koffler Scientific Reserve (KSR) at Jokers Hill on the Oak Ridges Moraine in King Township is quickly developing into a major venue for research and instruction in ecology, environmental biology and related areas of study.

Located on both sides of Dufferin Street, between 19th Sideroad and Davis Drive (Hwy 9), the Reserve was donated by Murray and Marvelle Koffler in 1995, in the largest ever single land donation to the University of Toronto. Until that time, the site, known as 'Joker's Hill Estate', had been a country home, a horse farm and an equestrian events center. Prior to the assemblage of the property into the 860 acre parcel we now know, it had been a collection of small farms that repeatedly changed ownership from the early 1800s until the 1950s. It was through this process of amalgamation that Joker's Hill ended up with the assortment of buildings currently on site. There are four large barns, an estate house, a Gazebo/dock-house, various out-buildings, and seven smaller single-family residences:

Joker's Hill Estate House (851 sm)

North Barn (630 sm)

South Barn (539 sm)

Arena Barn (1688 sm)

Arena Shed (174 sm)

Hospitality Barn (242 sm)

Equipment and Utility sheds (+/- 67 sm)

Laboratory for Biodiversity and Global Change Biology (790 sm)

Bath House (82 sm)

Latrines (22 sm)

7 single family dwellings: Echo Valley (152 sm), Hilltop House (107 sm), Harkaway (118 sm), Cottage (117sm), Wagon Wheels (104 sm), Willow Ridge (237 sm), Gatehouse (122 sm)

Some of these are grouped in clusters, consistent with their original use and some isolated. A number of natural features are located on the property including woodlands, watercourses and fish lakes.

The Koffler family continued to use the estate house as a residence until 2005, and several of the single-family homes were occupied by staff and tenants across the period of transition. By 1998, graduate students began using the houses to stay on site while performing research. Former reserve director Arthur Weis lived in the estate house from 2006 until operation costs became unmanageable, and the building has been closed since 2011.

KSR hosts more than 30 separate research projects per year, with representation from all 3 campuses, involving 29 PI's, 33 PDF's and technicians, and 60 undergraduate researchers and assistants (2013 data). For research, the site hosted over 2500 research user-days in 2013, an undergraduate involvement in research has grown exponentially over the last 6 years. KSR hosts approximately 1000 user days for undergraduate teaching. Undergraduate teaching use comprises residential field courses (1-2 per year), and short trips from courses on all three campuses of 30-100 students for 1-2 days.

In July 2011 a Task Force appointed by the Koffler Scientific Reserve Management Board prepared a KSR Real Estate Strategy which recommended freeing up scarce resources to advance the KSR research and teaching mission. The report included a strategy that would include building one or two multi-purpose use buildings in the area of the arena, south barn, north barn and workshop, and discontinuing the use of several outlying buildings. Future buildings would aim to reflect sustainable materials and design.

In October 2011 an external review of the KSR identified one of its handicaps as a field station was having to use pre-existing facilities designed for equestrian use and one of its greatest challenges would be to transform the former estate into a field station with improved overnight student accommodation in conjunction with a centralized meeting facilities purpose designed for field researchers. It was noted that one of the greatest assets a field station provides is the common dining hall, where users gather to share ideas, discuss problems and interact. New, clustered accommodation for students should be associated with the common dining hall/meeting spaces to enhance security and allow for appropriate management of the student experience. At the same time a plan to develop housing for resident PI's and post docs should be identified. It would be important for KSR to keep in mind ancillary uses of its facilities that would be mutually beneficial to the field station outside the intensive research season.

In 2017, Montgomery Sisam Architects were selected to design the new Operations Centre for KSR. Schematic design work commenced in fall of 2017, and was completed in February 2018. The proposal was positively reviewed by the Design Review Committee in February 2018. Fundraising material was prepared for the Faculty of Arts & Science. With funding sources in place, approval is being sought to proceed with the full implementation of the project.

#### **d) Statement of Academic Plan**

KSR currently serves four types of academic users, each with different needs for teaching and research: (1) Students on intensive, two-week residential field courses, (2) Students using KSR's facilities on day-trips or two-day excursions as part of regular classes, hosted on the three campuses, (3) Researchers, including PI's, post-docs, technicians, and undergraduates who stay in residence during their peak field season, and (4) Researchers who perform day-trips to KSR because of the lack of housing and/or dining accommodations. Collectively, usage of KSR across all of these groups has grown steadily in the last 7 years, to the point where housing is in short supply, and has to be managed carefully to avoid shortages where residential researchers are evicted to make space for students on residential field courses. Group dining options are non-existent, as are large meeting spaces.

Undergraduate work at KSR in residential field courses is not specifically required by any one program, although Ecology and Evolutionary Biology specialists are required to take two of three 400-level courses, one of which is a field course. The EEB Department offers several field courses per year, with the course hosted at KSR being the most affordable. Typical enrolment includes students from all three campuses, with most students majoring in Biology, Human Biology, Ecology and Evolutionary Biology, and other Life Sciences majors. The housing limitations at KSR mean that only one residential course can be hosted at a time, limiting course options offered by EEB—especially because the most sought after times for field teaching (early May/ late August) also coincide with heavy use periods for residential researchers. Dining solutions for residential courses were provided previously by the former director or staff, catering, or the students shopping and cooking for themselves as a group. Approximately 20 students gather for meals in the living room of a house on site, eating on resin folding tables.

Day use by regular semester courses offered on the campuses typically involve 700-800 user days per year. Trips to KSR are frequently required by individual instructors as exercises, field labs, or other components of their courses. KSR currently lacks large meeting spaces for presentations, lectures, or respite from poor weather. For example, ENV 234 often brings two groups of up to 100 students to KSR. There are no suitable buildings to house 80-90 people for announcements, instruction, or refuge from the weather. Undergraduate day trips come from diverse units such as EEB, Geography, ENV, UTM Biology, UTSc (Biological Sciences and iExplore), and Forestry. Collectively between residential courses and day-use courses, KSR hosts approximately 1000 user days for undergraduate teaching. A current goal is to expand day-use trips by regular courses hosted on the three campuses.

Research usage of KSR is voluntary, and largely driven by the needs of faculty for accessible, affordable field sites. KSR is unique in providing a space for large-scale manipulative experiments to test fundamental mechanisms in ecology and evolutionary biology, as well as sites for long-term study that are unlikely to be developed. Research at KSR spans all three campuses, the ROM, and undergraduate units as diverse as EEB, CSB, the Dept. of Biology (UTM), Dept. of Biological Sciences (UTSc), Chemistry, Archaeology, Geography, and University of Toronto Institute for Aerospace Studies. Researchers study a variety of organisms from plants, to nematodes to hummingbirds, or use KSR to test unmanned miniature aircraft. Research projects address questions related to population, community and ecosystem ecology, ecological and population genetics, invasion biology, biodiversity, and evolutionary responses to climate change.

Funding from CFI to Professors Weis, Ensminger, McCauley, and Krkosek have facilitated the development of permanent research infrastructure to study evolutionary and physiological responses to global warming in terrestrial (Weis, Ensminger) and aquatic systems (McCauley). Experimental stream and pond installations (McCauley, Krkosek, Rowe, Gilbert) will substantially expand the teaching and research capacity for aquatic ecology and evolution, as KSR has few naturally occurring aquatic habitats. KSR hosts approximately 2500 research user days annually. Current faculty hiring in EEB and the Department of Biological Sciences (UTSC) has the potential to expand research and teaching use at KSR, exacerbating the housing shortage and dining facility needs.

**e) Space Requirements**

*Occupant Profile*

	Existing	Planned
Staff	3	3
Research	40 projects, 15-20 PIs/postdocs	
Housing	33	40 new + existing

*Student Housing—Recent Past and Current Status*

Distributed housing across four of the residential houses worked reasonably well during KSR’s early growth, when demand and use of the site for teaching and research were considerably lower than today. Apartments above the horse stalls in the North Barn were used by undergrad and graduate students until the building was deemed unsafe. The loss of the North Barn housing, combined with an increasing population of undergraduate research assistants, began to strain the capacity of the houses. At the peak, one of the houses (a split-level ranch) housed up to twenty undergraduates, some on couches, or in one case, on a cot under the stairs. On top of the overcrowding, residential field courses in the summer months also required housing, causing research residents to be uprooted and re-shuffled, sometimes with little or no notice. The net effect was a severe limitation on student educational and research experiences and opportunities.

Currently, researchers and students reside at KSR in a compromised situation, at best. Bathrooms and bunk-beds were added to the houses as a stop-gap, and we now house 7-10 students per house, with each house having 1-2 bathrooms and limited kitchen space. Bedrooms, bathrooms, and kitchen facilities are strained beyond capacity in the height of the season, and houses sit empty over the costly winter months. The houses are widely distributed from each other, and from the lab building which is the central site for teaching and research activity. In many cases, the most direct walking route between houses is on largely unlit portions of 19<sup>th</sup> Sideroad and Dufferin Street. KSR is also currently unable to house two residential

field courses and residential researchers at the same time, limiting educational and research opportunities.

#### *Housing and Dining Facilities-- Needs*

The single greatest challenge facing KSR is to improve the housing and dining facilities to change KSR from a field site with distributed housing to a field station where the teaching, research, and social dimensions of field work reinforce each other. The most recent external review of KSR noted this explicit terms:

“But it is apparent to us that the greatest need at KSR is for improved student accommodation in conjunction with a centralized meeting/dining facility. One of the greatest assets a field station provides is the common dining hall, where users gather several times a day, share ideas, discuss problems, develop strategies for solving problems, offer each other help, communicate and interact in a way that fosters interaction between undergraduates, graduate students, post-docs and faculty researchers, and facilitate a sense of community. The synergy that is generated from such a facility should not be underestimated. By having students live in out-lying cottages/houses, and with no common dining facility, KSR is losing out on one of the most rewarding, enjoyable, synergistic, and productive aspects of a field station.”

As previously noted, grad student researchers that we interviewed unanimously identified improved housing for students, both for research students and for field course students, as the most pressing need at KSR. New accommodations should address this need, at the same time as developing housing for resident PI's and post-docs. Existing cottages/houses could be appropriate for the latter, often with families, if new accommodations were built for students. The new student housing needs to be built in a central location, preferably as clustered, individual units, all associated with a common dining hall/meeting space. A centralized location would have the added benefit of providing much greater security for students than is currently available in the existing outlying cottages/houses, many of which are on the periphery of the reserve.”

A common dining facility with individual housing units will also serve several other objectives: KSR currently lacks any rooms rated for more than 18 people, leaving no space for research seminars, public seminars, or even a place for field trips associated with courses run on campus to take shelter from cold/inclement weather. A central dining hall solves all of these problems simultaneously. Properly designed, modular, purpose-built student housing units can be effectively shut down for the winter months, saving on fuel and heating. The current approach of heating empty, outlying cottages through the winter months to keep the pipes from freezing or foundations from cracking is incompatible with the global change focus of the reserve's research programme.

The lack of housing on site in peak research season leads to regular day-trip commuting. Vehicle chargebacks cost PIs \$50-60 in research expenses for mileage, and lead to increased environmental costs and traffic.

The lack of housing appropriate for faculty and/or post-docs, many of whom have families, severely limits our ability to retain faculty presence throughout the summer, limiting educational opportunities for students, and field work opportunities for PIs and post-docs. Construction of new student housing facilities would allow a small number of existing cottages to become resident faculty or PI housing.

### III. PROJECT DESCRIPTION

#### a) Vision Statement

The new dining and accommodations facilities at KSR will transform the property and educational, research, and teaching experience by providing a centralized location for meeting, dining, teaching, and housing. By facilitating group dining experiences, large meeting places for research seminars and classes, and individualized housing for researchers, students, faculty, and visitors, the new facility will offer: flexibility; private accommodations; shared social, dining, and learning spaces; and a field research and teaching experience that is currently unavailable at KSR or on the campuses.



View from west



View of entry

The dining and operations centre will be a modern reference to the vernacular, in keeping with KSR's architectural and agricultural heritage and the nature of ecological and evolutionary field work. Inside, however, the centre will offer modern kitchen facilities, distributed tables for group dining and research discussions, and when the tables are put away, a large meeting space (with projection equipment) for presentations, classes, and public lectures. Wherever possible, natural light, insulation, energy efficiency, and modern design aspects will be used to promote sustainability, reduce heating and electrical costs, and allow operations consistent with the reserve's focus on global change research and teaching. Integrating a limited number of 4 season bedrooms, the dining and operations facility will expand accessibility and allow year-round visitors, researchers, and provide flexible housing space for peak usage period. Integrating common shower and bath-house facilities into the building will minimize water usage, the number of septic fields, and our collective environmental impact on the Oak Ridges Moraine.



View from south

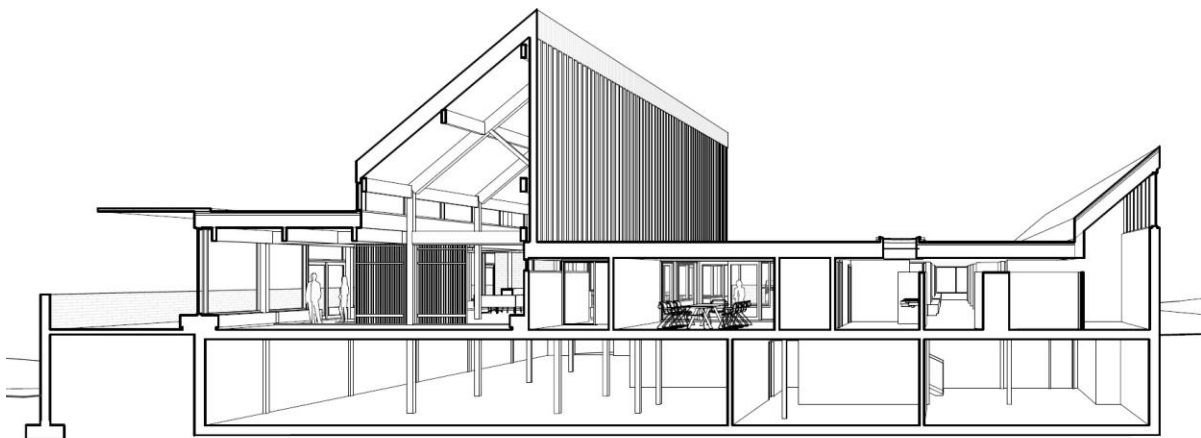

Section looking west

A distributed set of three-season, 2-3 person bunkies, artistically arranged around the dining facility and integrated into the natural landscape will expand flexibility and privacy for accommodations. The dining

facility will be a close walk away, and centrally located near the main laboratory space. With only electrical service to each bunkie, off-season shut-down will be easy and consume minimal energy when not in use, lowering both operating expenses and environmental impacts of housing. A large number (20) of bunkies will allow flexible expansion and contraction of the number of occupied beds, depending on need, seasonal demand, and the number and type of courses and researchers at KSR. The modular, individualized nature of bunkies will allow privacy, early rising for research and teaching to be done before dawn, and flexible bed times for diverse researchers, faculty, and students of different ages.

The project requires the demolition of the North and South Barns, as well as the Hospitality Barn. The Arena Barn will remain in place, and will receive a new poured concrete floor and modest upgrades to its building envelope.

## **b) Space Program and Functional Plan**

### Bunkies

Planned at 9sm, the bunkies will be small structures, with minimal furnishings. Generally, one set of bunk beds, one single bed, hanging rods and a small table should be included. The bunkies are to be rustic, with interior exposed wood structure, intended to impart a “camp” feeling. The bunkies should be well-spaced from each other, primarily on the South Barn footprint. Electricity should be supplied to each bunkie, but plumbing, heating and air-conditioning is not required for these seasonal-use structures.

### Dining Room

The dining room will become a central gathering space for all faculty, staff, students and visitors to the Reserve. Adjacent to the kitchen, it should have access to an exterior patio to allow for outdoor dining in the warm months. This patio will have the potential to be enclosed in the future. Flexible furnishings are critical to allow for various configurations of use.

### Bedrooms

Five bedrooms will be provided, each with two bunkbeds. The bedrooms will have hanging space, shelving space and one student desk. Located on a separate wing from the dining area, the bedrooms are away from high-traffic and noisy areas. At least one bedroom must be wheelchair accessible.

### Lounge

The lounge is part of the central gathering space, located in close proximity to the dining area for ease of student access. A casual area, it will be furnished with couches and tables. Views to the exterior are incorporated into the design.

### Classroom

The classroom will be used for a variety of teaching situations and must accommodate different group scenarios and interactions. Tables and chairs should be chosen with flexibility in mind, durable, and easy to clean.

### Kitchen

The kitchen will be equipped with the required equipment to facilitate the cooking of group meals. Adjacent to the Dining Room, it will be open and accessible.

### Shower Rooms

Male and female shower rooms will have access from both the interior and exterior, as they will serve students residing in both the bunkies and the bedrooms located in the building. Shower rooms include



both showers and a changing area, and at least one washroom each. Finishes will be durable and easily cleaned.



Site Plan

**Space Program**

# Rms		Nasm Per	Total Nasm	Year round or Seasonal
A. Shared Facilities				
5	bedrooms with bunks for 4 each	20	100	Y
1	Common Kitchen, with servery,	100	100	Y
1	Dining room, 60 seats	115	115	Y
1	Outdoor patio	100	100	S
2	Shower Rooms, 4 showers each, 4 toilet, 4 sink	20	40	Y
1	Laundry Room, 3 washers, 3 dryers	10	10	Y
1	Lounge, seat 20	35	35	Y
1	Furniture Storage Room	15	15	Y
1	locker room, 10 lockers	20	20	Y
1	Director's office	17	17	Y
1	Assistant Director	13	13	Y
1	Reserve Administrator	13	13	Y
1	Workroom, 4 stations	20	20	Y
1	Meeting Room, 6 people	15	15	Y
1	Files storage, copy, supply room	11	11	Y
1	Classroom for 35 people	75	75	Y
2	public washrooms, each with 2 sinks and 2 toilets	12	24	Y
B. Bunkies				
20	Bunkies	9	180	S
	Total Nasm Build New		903	
	Total Gross Build New @ 1.75 (no gross-up factor for bunkies)		1445	
C. Workshop & Storage (EXISTING SPACE IN ARENA BARN)				
1	Staff Workshop	100	100	Y
1	Researcher Workshop	30	30	Y
1	Garage, 2 car	30	30	Y
1	Storage	500	500	Y

Site Adjustments

Total gsm demolished                      1585 sm  
(North, South and Hospitality barns)

Total gsm added                              1422 sm

## c) **Building Considerations**

### **Building characteristics and massing**

The main building is one storey in height and will include a basement. No mechanical penthouse will be required. Materials are expected to impart a rustic character, similar to other 'camp' type buildings. Interior finishes should be durable and easily cleaned. The use of sustainable materials is highly encouraged.

Bunkies will be constructed in wood, and require few interior finishes. They will be 1 storey in height, without a basement, and will likely sit on sonotube foundations. The bunkies are to be well-distributed with a courtyard relationship.

In the preparation of this report, the committee cited other university research stations as peer facilities. In particular, the Operations Centre at Queen's University Biological Station, on Lake Opinicon, was noted as a building that exemplified the aesthetics and character the committee is seeking for this project.

### **Key building components and systems**

#### Mechanical/ Electrical and Data

Ventilation and air conditioning will be properly designed to provide adequate circulation. Windows will be capable of being opened. Mechanical equipment will be housed in the basement; no mechanical penthouse will be required.

#### Accessibility

The main dining/accommodation facility will be fully accessible, in compliance with new AODA standards, recent OBC changes and the University's own accessibility design standards. At least one full-season dorm room will be wheelchair accessible. Also required will be visual alarms and power door operators; and clearance for mobility devices resulting in wider door widths, turning radius, and path of travel.

#### Servicing

Waste is currently being collected by King Township, at the property line, once weekly. This service will continue. Deliveries will be made to the new dining/operations centre. No special loading areas are required.

#### Elevators

No elevators will be required for this project.

#### Sustainability design and energy conservation

As an environmental research centre, the Koffler Reserve expects this project will be an exemplar in sustainable design and green construction. The design is targeting carbon neutral through the employment of the following approaches:

- Passivhaus: the efficient building shape, solar exposure, superinsulation, advanced windows, ventilation with heat recovery, ventilation air-preheating and thermal bridge-free construction will drive thermal efficiency.
- Renewable energy source: the south roof of the both the new building and the Arena will accommodate an extensive array of photovoltaic panels. The project will achieve a minimum of LEED Gold standard.

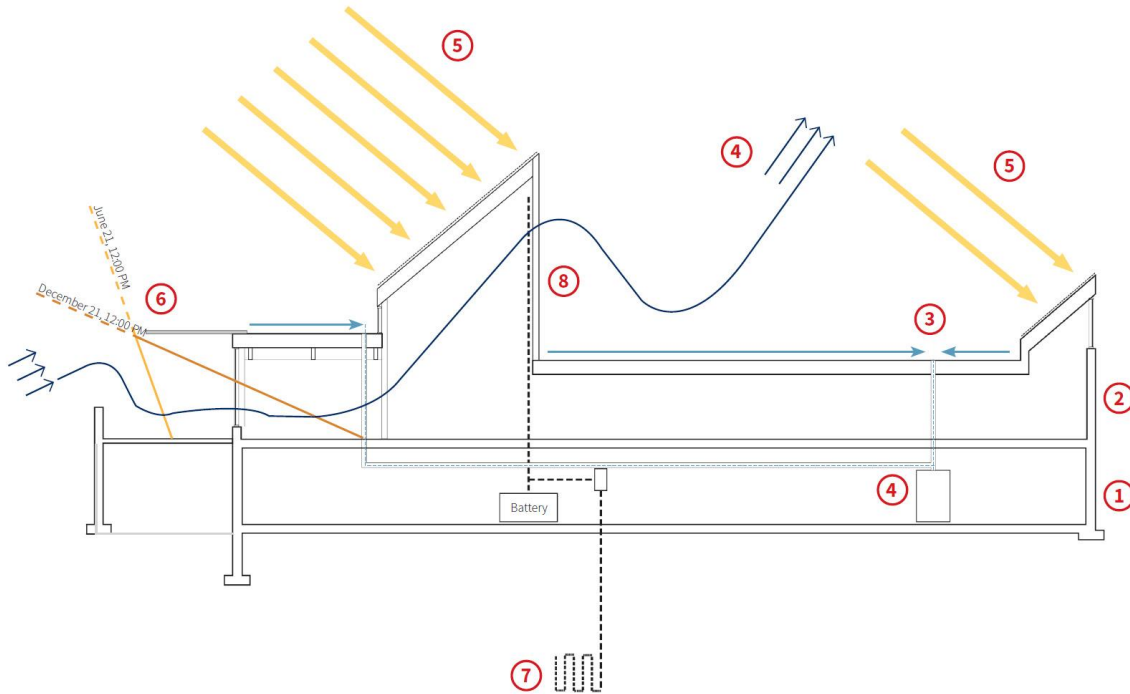

The above diagram illustrated the specific strategies to achieve a carbon neutral building

1. Insulated concrete forms R25
2. Structural insulated panels R40 to R50
3. Storm water capture to filtration system to supplement well water
4. Cross ventilation
5. Photovoltaic panels to feed power grid with some battery storage for pedagogic purposes
6. Sun Shades to maximize winter sun penetration and minimize summer sun penetration
7. Ground Source heat exchange
8. Daylighting

### **Identification of areas of demolition**

The South Barn, North Barn and Hospitality Barn will be demolished. The Arena Barn will be retained and used for workshop and storage space. The out building to the south will be demolished. There are two septic tanks serving these barns. As part of the demolition of these buildings, the existing septic systems will also be removed.



North Barn



Hospitality Barn



South Barn



Out building at Arena Barn

**Impact on existing occupants**

Research and teaching on the Reserve is expected to continue throughout construction. The current housing will remain in place and operational, allowing for the Reserve to function as normal. There are materials stored in the barns slated for demolition, and this material must either be disposed of or relocated. A transportation/access plan will need to be in place during construction which may require the temporary closure of one of the two driveways.

#### **d) Site Considerations**

##### **Zoning regulations**

The KSR property sits on the Oak Ridges Moraine and is subject to numerous policies and regulations beyond the King Township Zoning Bylaw. In order to move forward with this project, the University has successfully re-zoned the land to accommodate the new building. The rezoning was approved by King Township in 2018.

The University's 2017 application indicated conformance with the following regulations: Oak Ridges Moraine Conservation Plan (2002); Places to Grow (2006); Greenbelt Plan (2005); York Region Official Plan (1994),(2010). The zoning by-law amendment will allow for the accessory assembly facilities and overnight accommodation for employees, visiting faculty and students. A planning report prepared by Walker Nott Dragecivic examined each of these policies in detail. Of primary importance is the location of the KSR on an area identified as a "Natural Core Area" within the Oak Ridges Moraine Conservation Plan.

The purpose of Natural Core Areas is to:

*Maintain, and where possible improve or restore, the health, diversity, size and connectivity of key natural heritage features, hydrologically sensitive features and the related ecological functions;*  
*Maintain or restore natural self-sustaining vegetation and wildlife habitat;*  
*Maintain the quality and quantity of groundwater and surface water;*  
*Maintain groundwater recharge;*  
*Maintain natural stream form and flow characteristics; and*  
*Protect landform features. (s. 11(1))*

The planning justification report noted that this project would not result in the need to substantially alter impervious surfaces related to access or parking, and that furthermore, through the research and educational activities of the University of Toronto, the proposed uses will facilitate the conservation and management of the KSR's natural environment, which will be maintained or improved as a result of the proposed uses.

Within the Natural Core Area certain specific land uses are permitted:

*Fish, wildlife, and forest management;*  
*Conservation projects and flood and erosion control projects;*  
*Agricultural uses;*  
*Transportation, infrastructure, and utilities;*  
*Home businesses*  
*Home industries;*  
*Bed and breakfast establishments;*  
*Farm vacation homes;*  
*Low-intensity recreational uses;*  
*Unserviced parks; and*  
*Uses accessory to other permitted uses. (s. 11(3))*

"Conservation projects" is not a defined term in the ORMCP, as such it is subject to interpretation. Use of the site under the KSR, an environment and conservation research facility, will primarily be the stewardship of the natural environment and the research related to the global environment and climate change. Thus, the planning justification report concludes the use is compatible with the Natural Core Area.

KSR is placed in a Rural General Zone (RU1) by By-law 74-53. The RU1 Zone permits a range of non-specialized farm agricultural and forestry uses; and accessory uses. Resident and staff accommodations are also permitted in association with permitted agricultural and forestry uses. On March 18, 2009 a minor variance to the zoning by-law was approved in order to permit the use, conversion, and refurbishment of the former racing barn for conservation research and assembly facility purposes.

The proposed education and conservation uses with accessory overnight accommodation and shared common areas were not specifically listed as a permitted uses in the RU1 Zone and thus a zoning by-law amendment was required.

KSR is also located within the Glenville Hills Kames ANSI, an “Area of Natural and Scientific Interest. ANSIs are “areas of land and water that represent significant geological (earth science) and biological (life science) features”. ANSIs are identified by the Ministry of Natural Resources and are determined to be 'provincially significant' and have the “highest value for conservation, scientific study and education”.

**Site boundaries, conditions and constraints**

The plan below shows the area that was subject to a natural heritage study. Natural Core areas, ANSI lines, and setbacks from forested areas are indicated. The area that remains available for development is located within already disturbed land, primarily on the footprint or in the vicinity of the existing buildings.

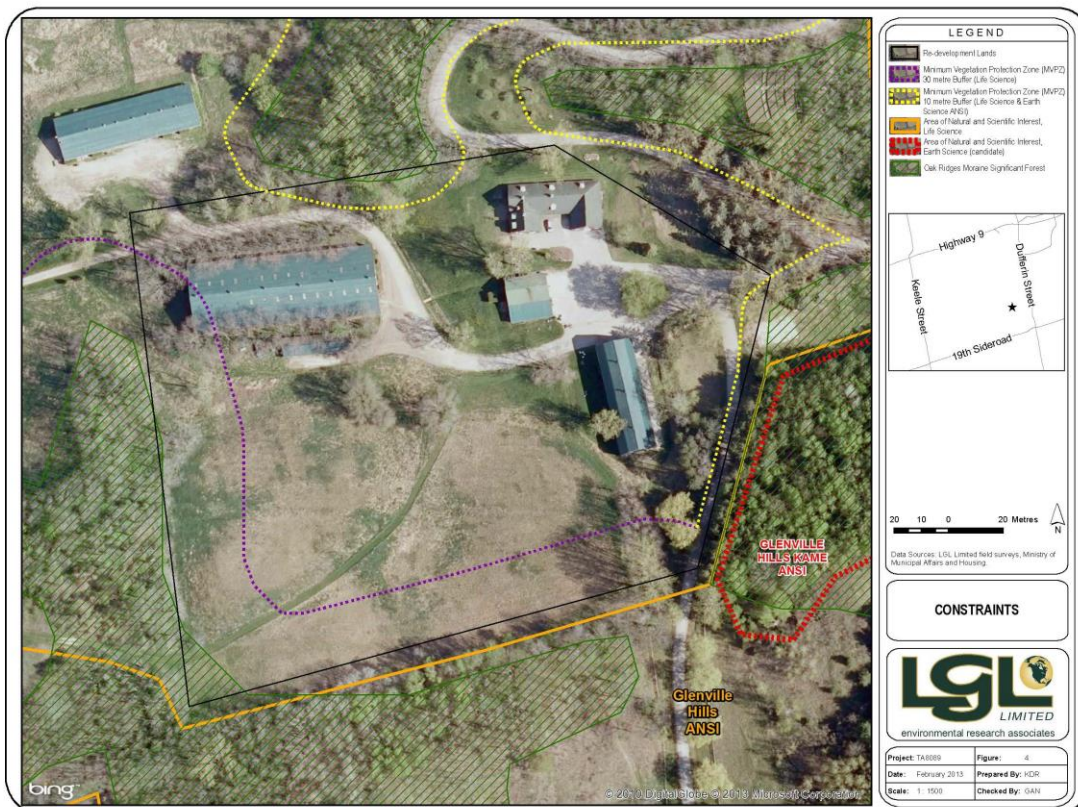



**Relationship of new construction to adjacent buildings, structures, open spaces**

The new building will be situated on the footprint of the North Barn and the Hospitality Barn, with the main entry from the existing parking lot. The majority of the bunkies will be situated in and around the open field to the south.

Site plan of proposed development area

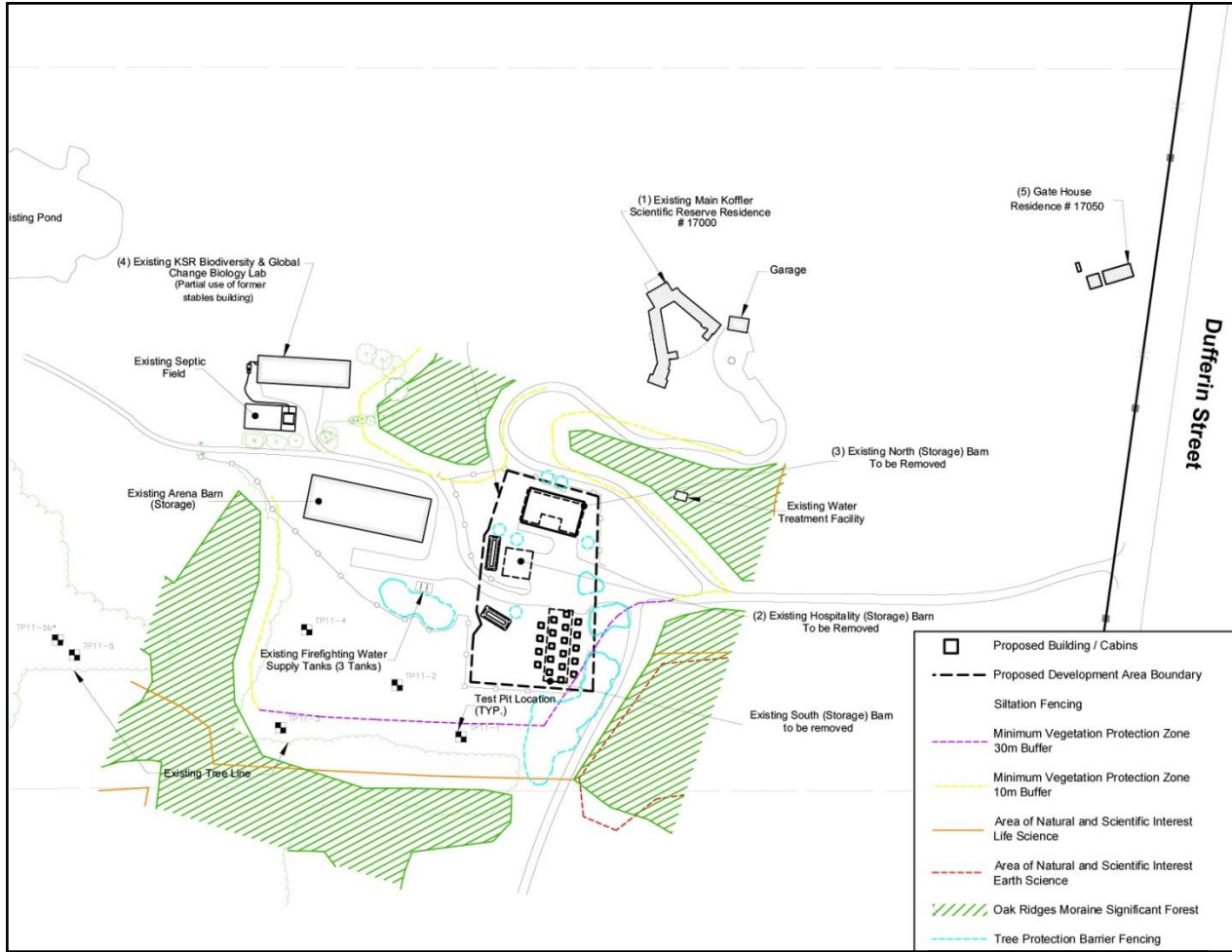

**Site access**

Vehicular access to the west side of KSR is via five existing driveways, three on Dufferin Street and two on 19th Sideroad. Of these driveways, three provide access to existing single detached dwellings, and two provide access to the Joker’s Hill main cluster of buildings. Internal circulation is accommodated by private driveways, foot paths and trails. The driveways in particular are to be maintained in their existing condition and not proposed to be expanded or altered.

**Heritage status**

None of the buildings impacted in this project planning report carry heritage status. In 2011, a heritage assessment was prepared for the Estate House by ERA Architects. This report is available upon request.

## Soil conditions

### Site servicing

Gunnell Engineering Ltd was retained by the University to prepare a Functional Servicing Study that addressed the existing infrastructure for water and sewage services, projected future needs and stormwater management. The findings of their report is found in the Sewage, Water Supply & Treatment and Stormwater sections below:

### Sewage

The west property currently contains a total of eight existing sewage systems.

A new replacement sewage system was recently installed in 2009 to accommodate the conversion of a portion of the existing Race Barn Building into a new day use KSR Biodiversity and Global Change Biology Lab.

The proposed development involves the demolition of the North Barn, the South Barn, and the Hospitality Barn. An existing sewage system services the North Barn Apartment (3 bedroom, 2 bathroom, daily design sewage flow = 1,600 litres/day). It consists of one 4,500 litre septic tank, and one filter bed with 64 metres of distribution piping. The existing septic system will be removed. Additional and new sewage capacity is required for the new dining and operations centre. The bunkies will not be serviced with water or sewage. Field investigations were completed in November 2011 to verify soil and shallow groundwater conditions on the property in areas adjacent to the proposed re-development area, for a proposed new onsite sewage system. The investigation included the excavation of nine septic test pits to classify the surficial soils and to identify shallow groundwater elevations.

The area just west of the proposed cabins was identified to be the most suitable location for a new sewage septic field area. Based on soil percolation rates, topography, and absence of groundwater in the septic test pits, a tertiary sewage treatment system with a shallow buried trench dispersal field has been proposed and will be designed in accordance with Ministry of the Environment guidelines and the Ontario Building Code to treat the effluent from the proposed 'Main Building'. This new sewage system will also replace the older, outdated Sewage System #2 (Hospitality Barn) and Sewage System #3 (North Barn Apartment). Sewage Systems #2 and #3 will be decommissioned.

The proposed estimated total daily design sewage flows for the west property (land west of Dufferin Street) is 31,500 litres per day, being an increase of 15,000 litres per day from the existing daily design sewage flows. For Ministry of the Environment and Climate Change sewage designs, being greater than 10,000 litres per day, the requirements of Section 53 of the Ontario Water Resources Act must be adhered to. Specific requirements include a "Reasonable Use Assessment", a hydrogeology study, and detailed assessments for phosphorous and nitrates.

An important aspect of a proposal to discharge sewage effluent into the environment is an assessment of the assimilative capacity of the receiver. The impact assessment should consider the various uses of the receiver. For the proposed sewage system, the surface waters of the two on-site ponds located at the base of the sloping lands on the north-west portion of the property are considered to be the receiver. These ponds are located in the headwaters of Keele Creek, which flows north-west off the property to the South Canal, which drains into the Holland River.

All proposed sewage treatment and sewage collection lines are to be designed based on the Ministry of the Environment (MOE) Design Guidelines for Sewage Treatment Systems 2008, and all applicable MOE supplemental guidelines and Ontario Building Code requirements. A

formal application to the MOE for an amended Certificate of Approval (now referred to as an Environmental Compliance Approval) will require to be submitted and approvals be obtained prior to the commencement of any installations. Sewage treatment system and subsurface disposal field details will be designed and addressed at the approvals stage through the MOE Environmental Compliance Approval application process.

### Water Supply & Treatment

The proposed facility will be serviced with treated well water from the existing on-site water treatment system, which also services all of the current Koffler on-site buildings located on both the east and west sides of Dufferin Street. The wells, main treatment system, and low-lift pump house are located on the eastern portion of the property, and the reservoir, high lift pumps, and supplemental treatment equipment are located on the western portion of the property.

The existing water treatment system has been categorized as a Non-municipal Year-Round Residential Water System. The average water taking for the existing property is 18.52 cubic meters per day, which equates to 4,854 gal/day or 18,350 L/day. The water meter readings are taken from the water meter installed in the pump house that supplies the entire centre. Maximum well capacity is 1.89 L/second. The water is drawn from interconnected wells on the property, and treated before distribution to the centre's facilities. A 2010 review of the system by Candomo Associates found the system to be functioning properly and in full compliance with provincial regulations.

The existing water treatment and distribution system will be able to service the proposed new facility, with possibly some minor updating. It is estimated that with the new facility and other remaining buildings, the overall property will likely use an estimated 25,000 litres/day. Pump tests will be required to be undertaken to determine if increased storage reservoir capacity will be required.

Water distribution for the proposed facility will be based on the Ministry of the Environment Design Guidelines for Water Treatment Systems 2008 and all applicable MOE supplemental guidelines. Currently, a certified operator is responsible for operating and maintaining the water treatment system to ensure that the treatment system meets the MOE Ontario Drinking Water Standards.

Since overall consumption for the property is less than 50,000 litres/day, a Ministry of the Environment permit to take water is not required.

### Natural Heritage

LGL Limited was retained by the University to prepare a Natural Heritage Evaluation (NHE) in support of rezoning the land to allow for this project. The study assumed that the development is to occur within the 120 metre Minimum Area of Influence and, in some areas, within the Minimum Vegetation Protection Zone (MVPZ) of important woodlands and significant kame topography. The woodlands surrounding the area of new development have been identified as significant under provincial legislation. The Glenville Hills kame topography is located 300 metres east of the area for development, on the east side of Dufferin Street.

The consultants concluded by indicating that development within the Area of Influence of a key natural heritage feature is permitted provided it will not cause adverse effects to the key natural heritage feature or its functions. This project intends to consolidate the functions taking place in existing buildings in one new building within a previously disturbed area. Existing disturbed areas will be re-naturalized as

determined at the time of a detailed submission for development and secured to occur upon completion of the construction of the new building.

**e) Campus Infrastructure Considerations**

**Electrical service**

The current electrical service includes two Hydro 1 transformers which feed an assortment of KSR-owned transformers. The main distribution room is located in the Hospitality Barn, a building scheduled for demolition. A second switch network provides power to the Gazebo, Gazebo bathrooms building, heating arrays, tennis courts, well and septic pumps.

While service capacity is ample, a new distribution room must be located in the new dining/operations centre. The Laboratory Building is also serviced from the Hospitality Barn distribution network, so provisions must be made to ensure electrical service remains in place while under construction.

**Storm water management**

As part of servicing Study, pre- and post-development stormwater flows were modeled based on the proposed development. The site is primarily made up of meadow and treed areas. Existing stormwater flows infiltrate these naturalized areas and eventually collect in two ponds and the headwaters of the Keele Creek. The ponds are located northwest of the proposed development envelope. The proposed development will not affect existing stormwater flows or stormwater quality. A total of 69.7 m<sup>3</sup> is required to maintain pre-development conditions during the first 4 minutes of a storm event. A total storage area of 101.7 m<sup>3</sup>/s is available within the grassed area, treed areas and gravel parking areas.

Additional swales are to be installed to convey water from downspouts and foundation drainage to the natural drainage direction. Additionally, two small berms, 0.3 metres high and 1.5 metres wide are to be constructed to capture overland flow.

**Communications (phone/data)**

Phone service is in place on site. Internet service to the Reserve has limited capacity and given its location, the infrastructure is unlikely to be improved soon. It is adequate for the work taking place on site but may limit the provision of newer technological features within the facility (video conferencing, etc).

**Roads and pedestrian pathways**

KSR has paved and unpaved areas that have been used as parking related to the various past uses of the Subject Site, including the horse farm. These traditional parking areas would continue to be utilized for vehicle parking, and could physically accommodate limited bus parking. The existing impervious surface condition is proposed to be maintained. No new parking areas are planned.

Each of the existing single detached dwellings independently provide parking and driveways, which are proposed to be maintained.

**f) Secondary Effects**

The Hospitality Barn operates as a reception/arrival point for visitors and students to the Reserve. The Station Manager also works out of this building. During construction, faculty, students and visitors will need to be directed elsewhere, likely toward the laboratory, further back within the Reserve. The Station Manager's office will need to be relocated as well.

**g) Schedule**

April 14, 2016	Approval by CaPS Executive for Interim Project Planning Report and expenditure of consultant services
June 2017	Consultant Team selection
February 2018	Schematic Design Complete
August 30, 2019	Approval by CaPS Executive for additional expenditure of consultant fees through Design Development
September 2019	Design Development
October 24, 2019	Governing Council, Cycle 1 2019-20
November 2019	Construction Documents
Spring 2020	Tender and Award
Spring/Summer 2020	Estimated Construction Start
Summer 2021	Occupancy

**IV RESOURCE IMPLICATIONS**

**a) Total Project Cost Estimate**

The total estimated cost for the project includes estimates or allowances for:

- b) construction costs
- c) contingencies
- d) taxes
- e) site service relocates
- f) infrastructure upgrades
- g) secondary effects
- h) demolition
- i) landscaping
- j) permits and insurance
- k) Professional fees, architect, engineer, misc. consultants project management
- l) computer and telephone terminations
- m) moving and staging
- n) furniture and equipment
- o) miscellaneous costs [signage, security, other]
- p) commissioning
- q) escalation

**b) Operating Costs**

Operating costs will be covered by the Faculty of Arts & Science and will be determined as the project is further advanced.

**c) Funding Sources**

The project will be funded through the Faculty of Arts & Science Building Fund and the Future Major Capital Project Reserves.

**APPENDICES:**

1. Room Data Sheets (on request)
2. KSR Design Brief (Schematic Design)

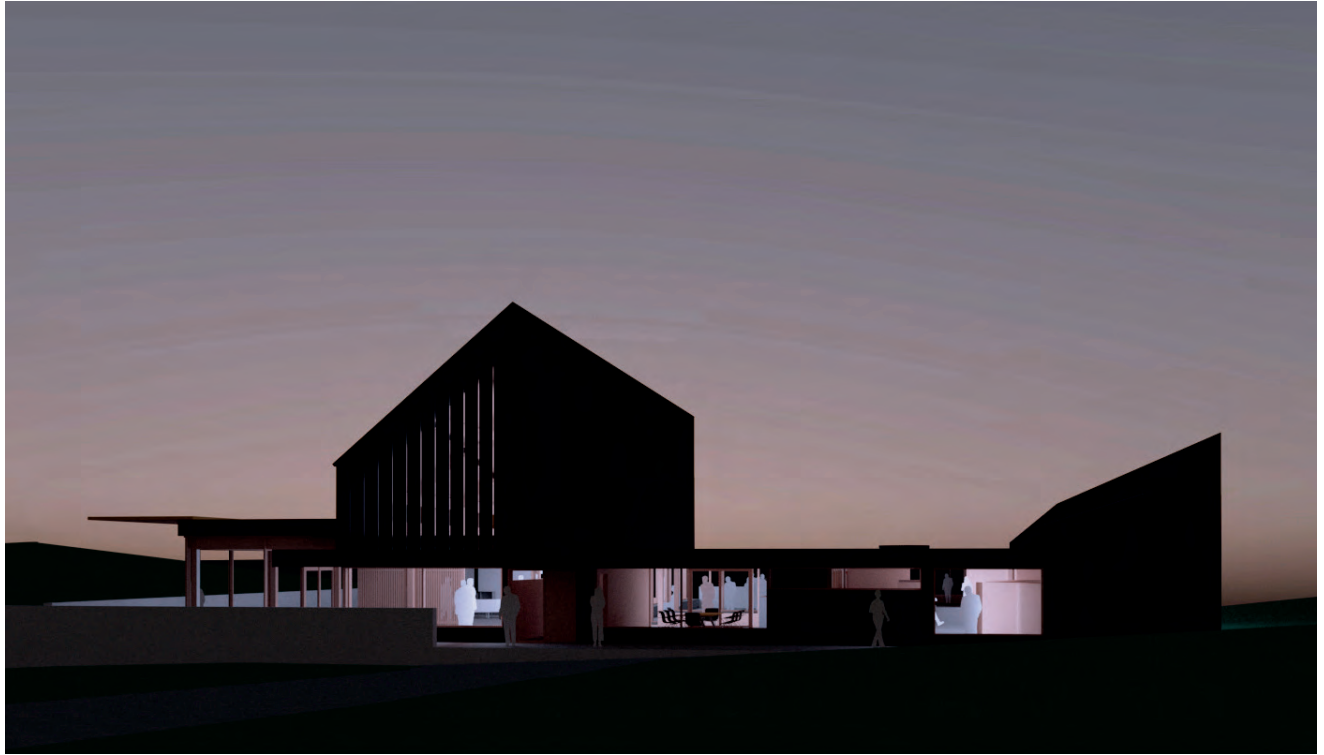

UNIVERSITY OF TORONTO

**KOFFLER SCIENTIFIC RESERVE**

MontgomerySisam



- 1 PURPOSE & PROGRAM**
- 2 SITE**
- 3 SUSTAINABILITY GOALS**
- 4 LANDSCAPE GOALS**
- 5 ARCHITECTURAL GOALS**



## 1 PURPOSE & PROGRAM



Main Building

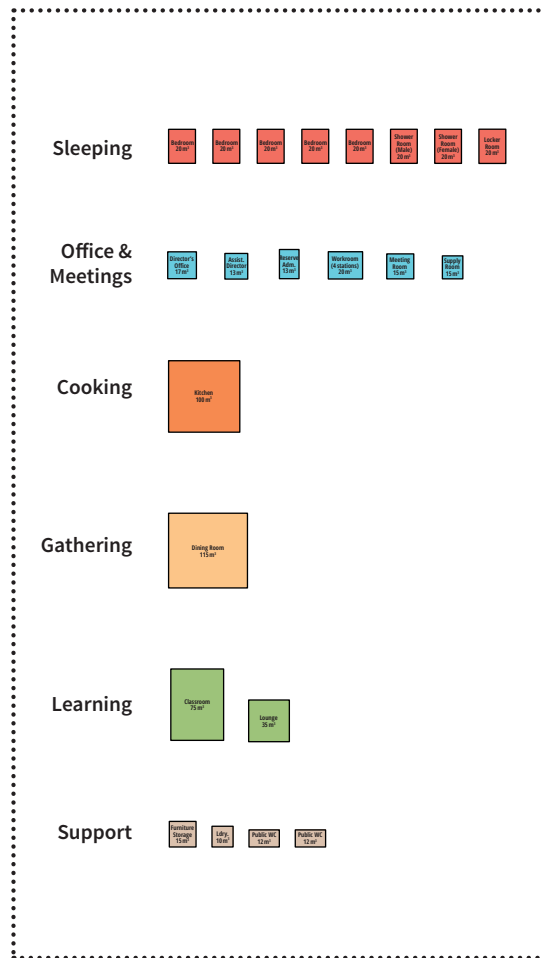

Bunkies

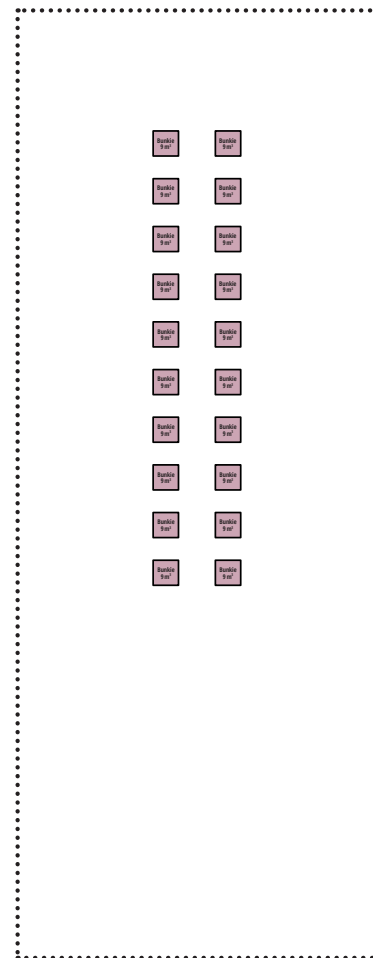

Workshop & Storage

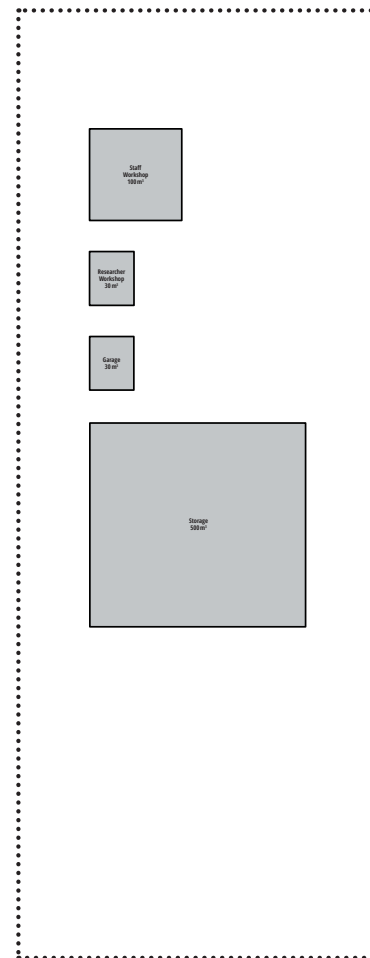

# 1. Purpose and Program

The purpose of the new building(s) at the Koffler Scientific Reserve is to provide sleeping accommodations as well as shared social, dining and learning spaces for researchers, students, faculty and visitors.

The program components will consist of:

- Dining Room
- Bedrooms (five) each with two bunkbeds
- Lounge
- Classroom
- Kitchen
- Shower Rooms
- Laundry Room
- Storage Space
- Locker Room
- Offices
- Meeting Room
- File / Copy / Supply Room
- Public Washrooms
- Bunkies (20)

In addition, the remaining barn will receive new workshop space, a garage and storage upgrades.



- ① *Koffler Scientific Reserve*
- ② *University of Toronto Mississauga Campus*
- ③ *University of Toronto St. George Campus*
- ④ *University of Toronto Scarborough Campus*

**The Koffler Scientific Reserve** (KSR) is located at Jokers Hill on the Oak Ridges Moraine in King Township.



The 860-acre parcel of land straddles Dufferin Street between 19th Sideroad to the South and Davis Drive to the North. The reserve was donated to the University of Toronto by Murray and Marvelle Koffler in 1995. Once a collection of small farms, the land was assembled in the 1950's as an equestrian events centre. An assortment of existing buildings from all eras remain on the site; these include four large barns, an estate house, a gazebo, various out buildings and seven small single-family residences. Some are clustered, consistent with their original use, while others are isolated from one another.

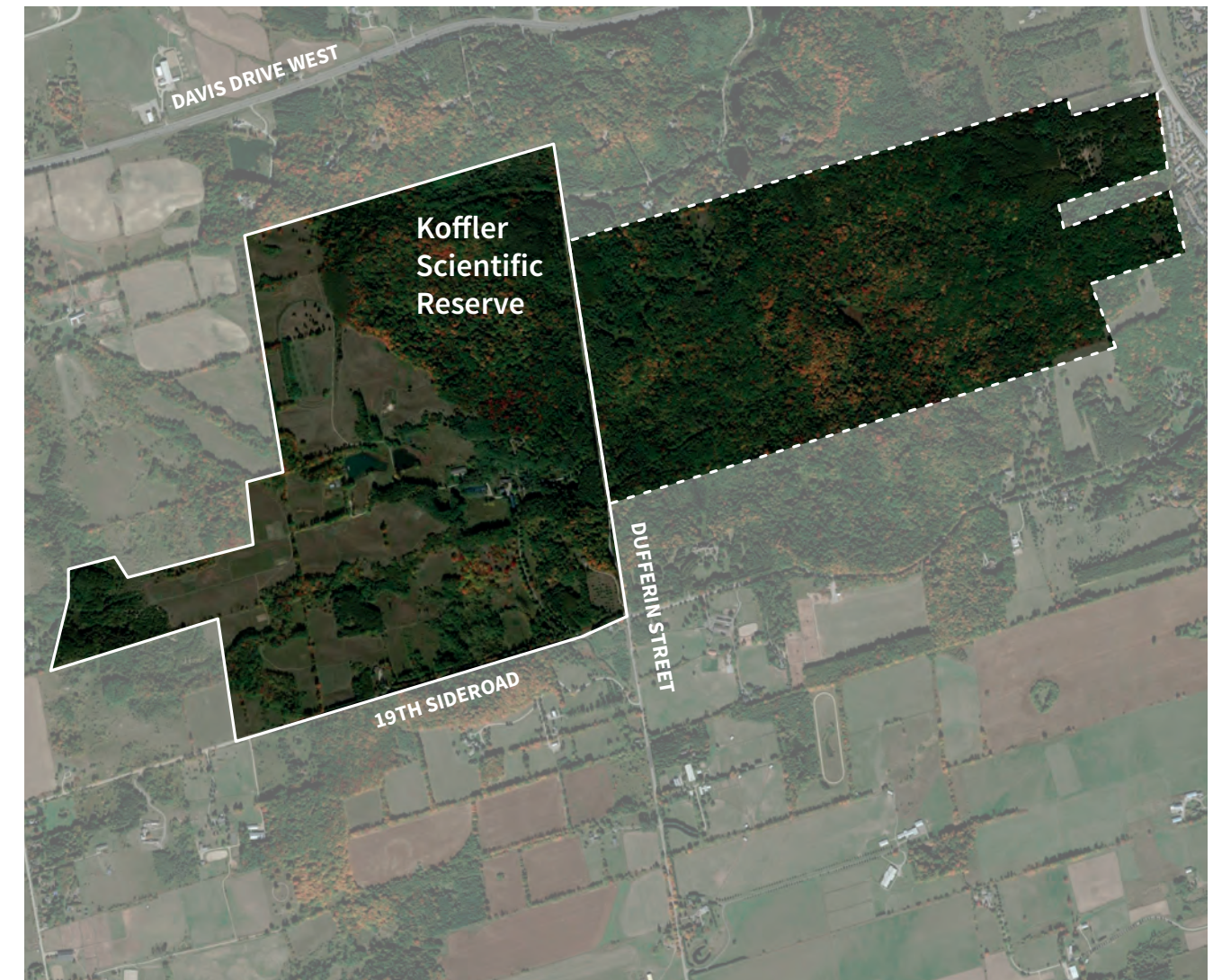

The **Oak Ridges Moraine** is an ecologically important geological landform, 1,900 square kilometres in area, stretching from Caledon in the west to Rice Lake in the east. Its' defining geomorphology is the presence of drumlins – shapely landforms that are the result of material ground up and deposited by retreating glaciers from the last ice age. Under the Oak Ridges Moraine Conservation Plan, the KSR property was designated a “Natural Core” area, the most restrictive in terms of development. KSR is also located within the Glenville Hills Kames ANSI, an “Area of Natural and Scientific Interest”. These policies serve to limit the scope and area of new construction on the site, and as a result this project will be built on already disturbed land and employ a restorative approach to the surrounding landscape.

The University has filed a re-zoning application that indicates conformance with the following regulations:

- Oak Ridges Moraine Conservation Plan (2002);*
- Places to Grow (2006);*
- Greenbelt Plan (2005);*
- York Region Official Plan (1994), (2010).*





① *Biology Lab*



② *Arena Barn*



③ *Koffler Residence*



④ *Hospitality Barn*



⑤ *South Barn*



⑥ *North Barn*

The amendment application has identified the **boundary limits** for this project and will include the **demolition of three barns and the removal of an asphalt parking area** that is in rough repair. Redevelopment will occur on already disturbed land and will not encroach on the Moraine.

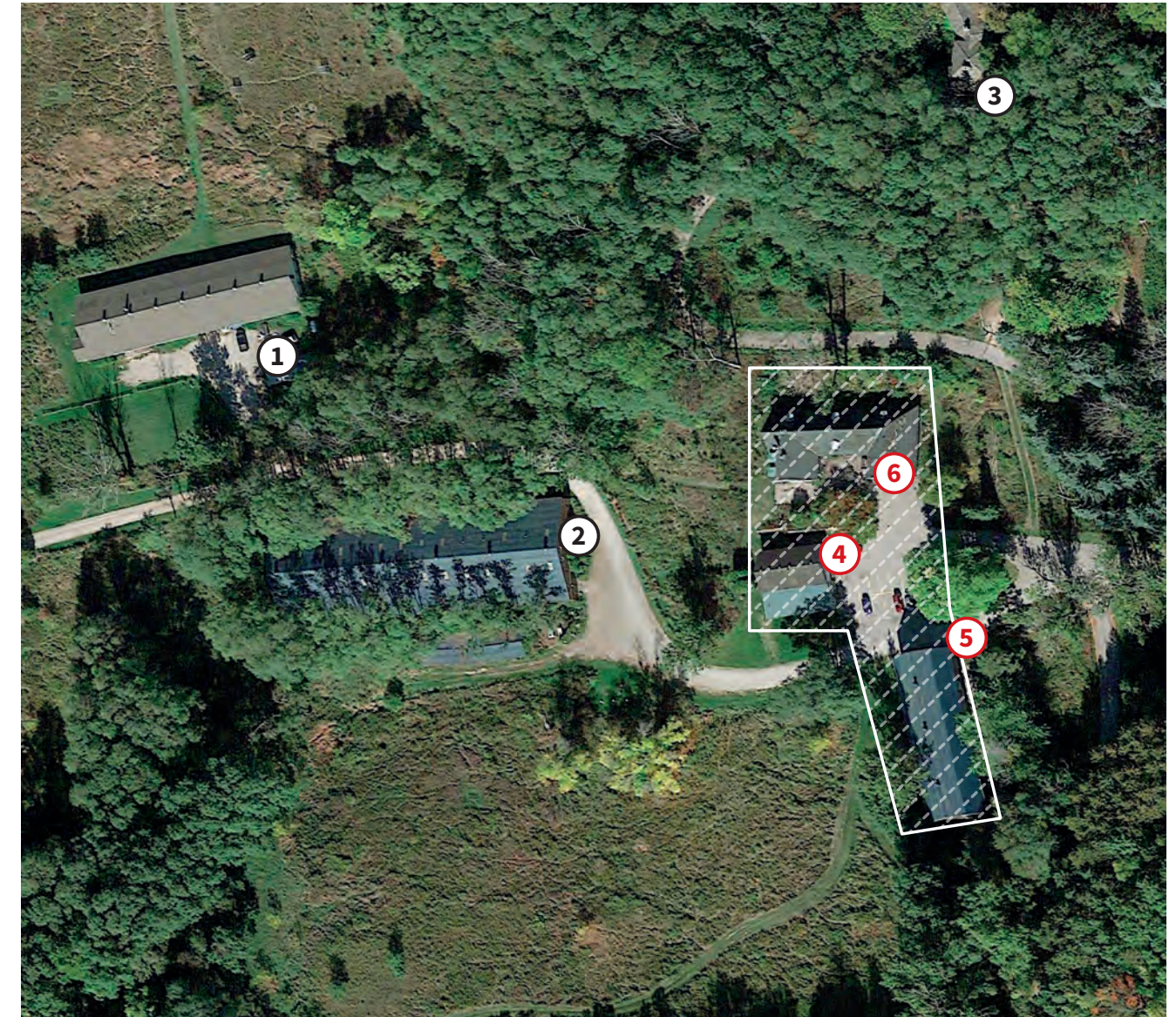

### 3 SUSTAINABILITY GOALS

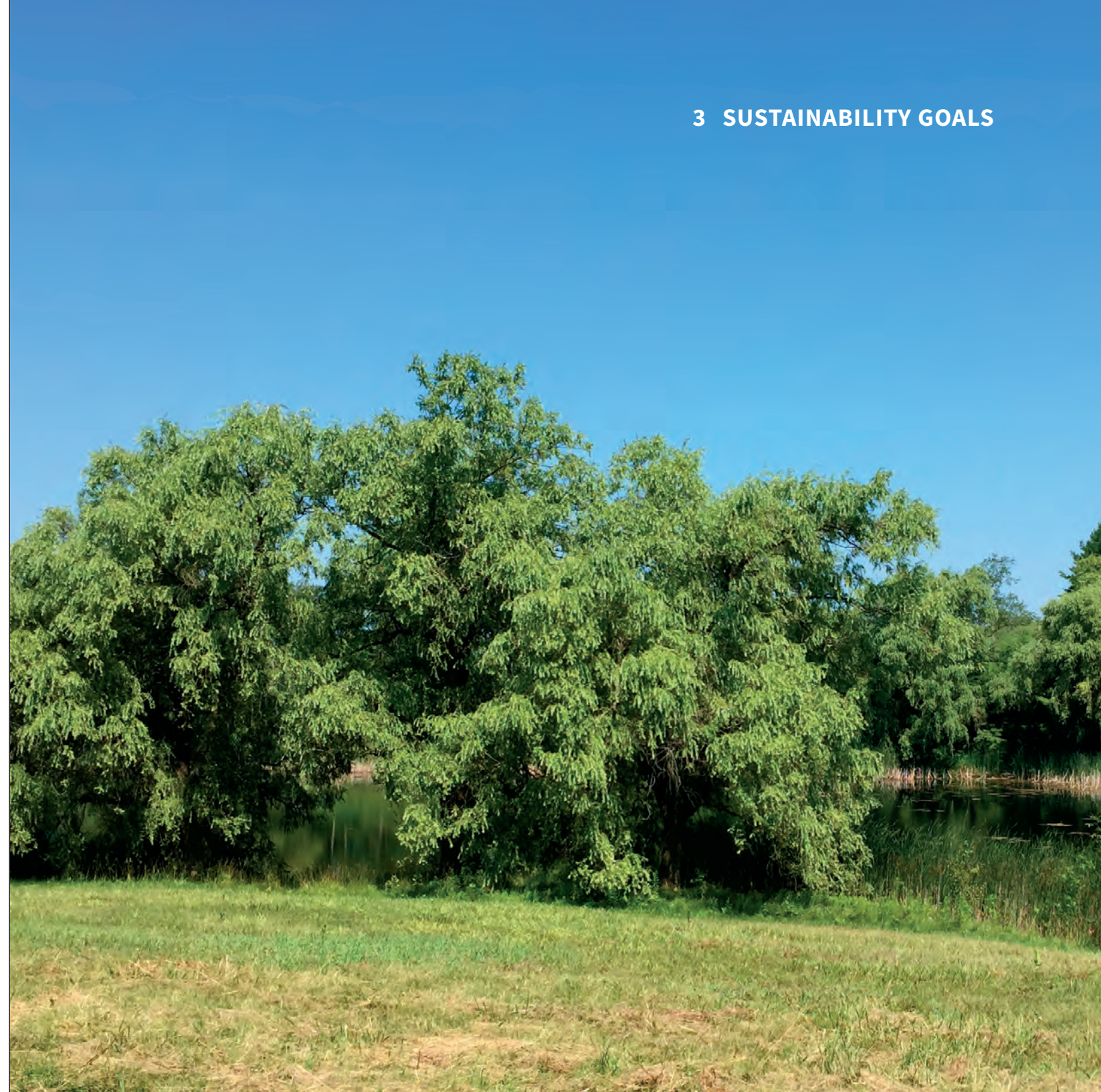





### 3. Sustainability Goals

The Koffler Scientific Reserve Dining and Operations Centre will be designed as an exemplar in sustainable design and green construction.

- Principles of **Passivhaus** – efficient building shape, solar exposure, superinsulation, advanced windows, ventilation with heat recovery, ventilation air-preheating and thermal bridge-free construction – will drive thermal efficiency.
- Potential **renewable energy sources** like photovoltaic panels and geo-thermal heating will support KSR’s carbon neutral target.
- **Battery storage** will also be investigated, though this may be solely for pedagogical purposes as the site is connected to the energy grid.

- 1 Insulated concrete forms R 25
- 2 Structural insulated panels R40 to R50
- 3 Solar thermal hot water panels
- 4 Storm water capture to filtration system to supplement well water
- 5 Cross ventilation
- 6 Photovoltaic panels to feed power grid with some battery storage for pedegogic purposes
- 7 Sun shades to maximize winter sun penetration and minimize summer sun penetration
- 8 Ground source heat exchange
- 9 Daylighting

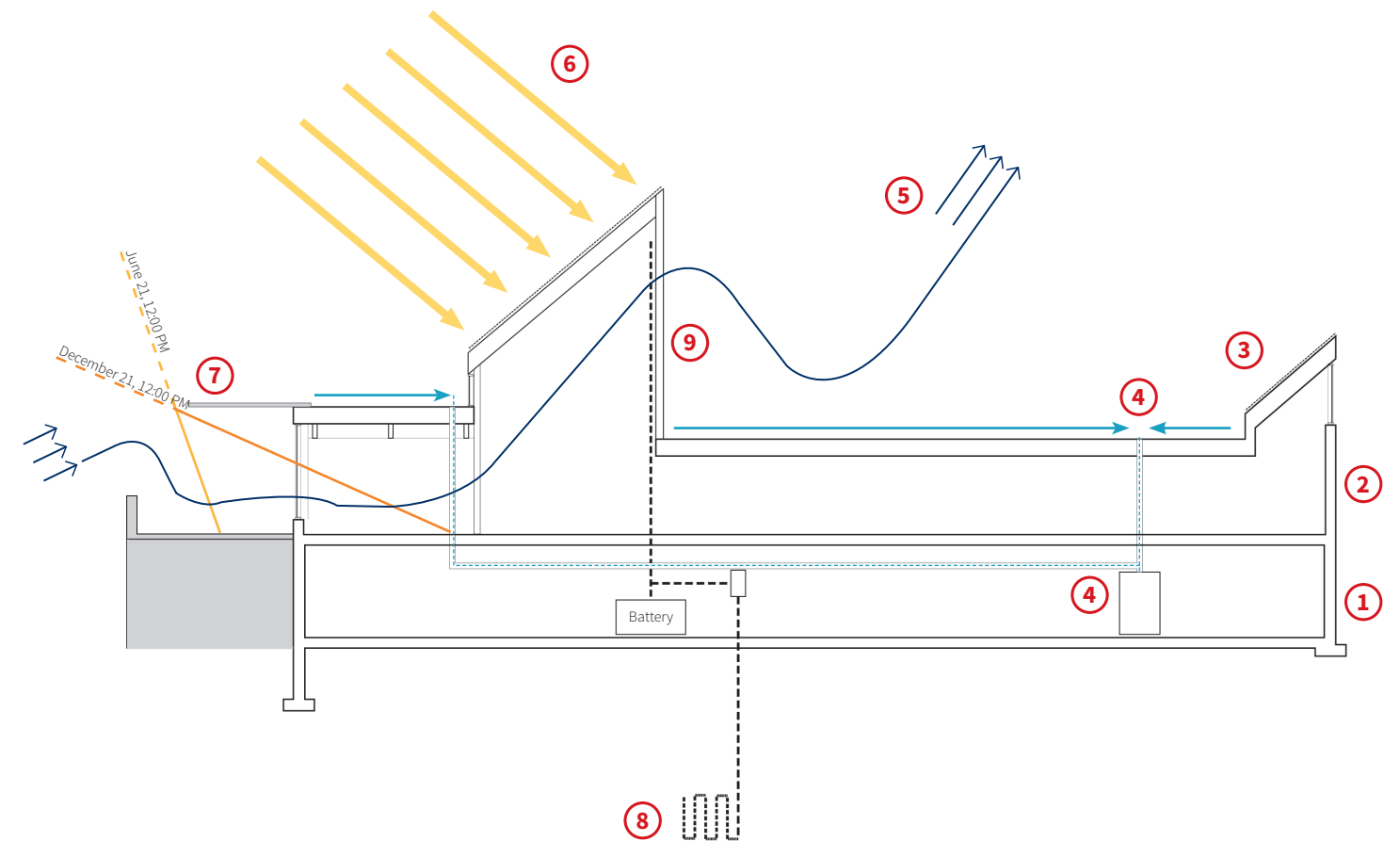

4 LANDSCAPE GOALS



## 4. Landscape Goals

The development site is located in an already disturbed area of the landscape, planted, years earlier, with a variety of native and non-native species. The understory landscape also includes a variety of native and non-native plants; these are quantified in the vascular plants of Jokers Hill report dated December 17, 2014.

Given the highly sensitive nature of the Moraine, landscape goals are twofold: firstly, to make a delicate impression on site by maintaining a restrained program, and secondly by contributing to ongoing restoration efforts.

- A combination of seeding and planting will be used to restore the footprint formerly occupied by the barns and drive shed in keeping with the existing landscape.
- Native tree plantings will be introduced to offer wind protection to the new buildings, provide shade in strategic locations and naturalize woodland edge plantings. Additional species may include pollinator plants, forage plants, bird friendly berried species, wetland and bioswale plantings.
- New habitats will also be introduced to the site; following a detailed review of the birds, mammals, reptiles and amphibian reports, these may include bat-boxes or barn swallow perches, as appropriate.
- Programmable spaces will include the intervention of a gathering area within the 'bunkie' quad.
- Landscape and civil disciplines will work closely in the development of the new septic area.

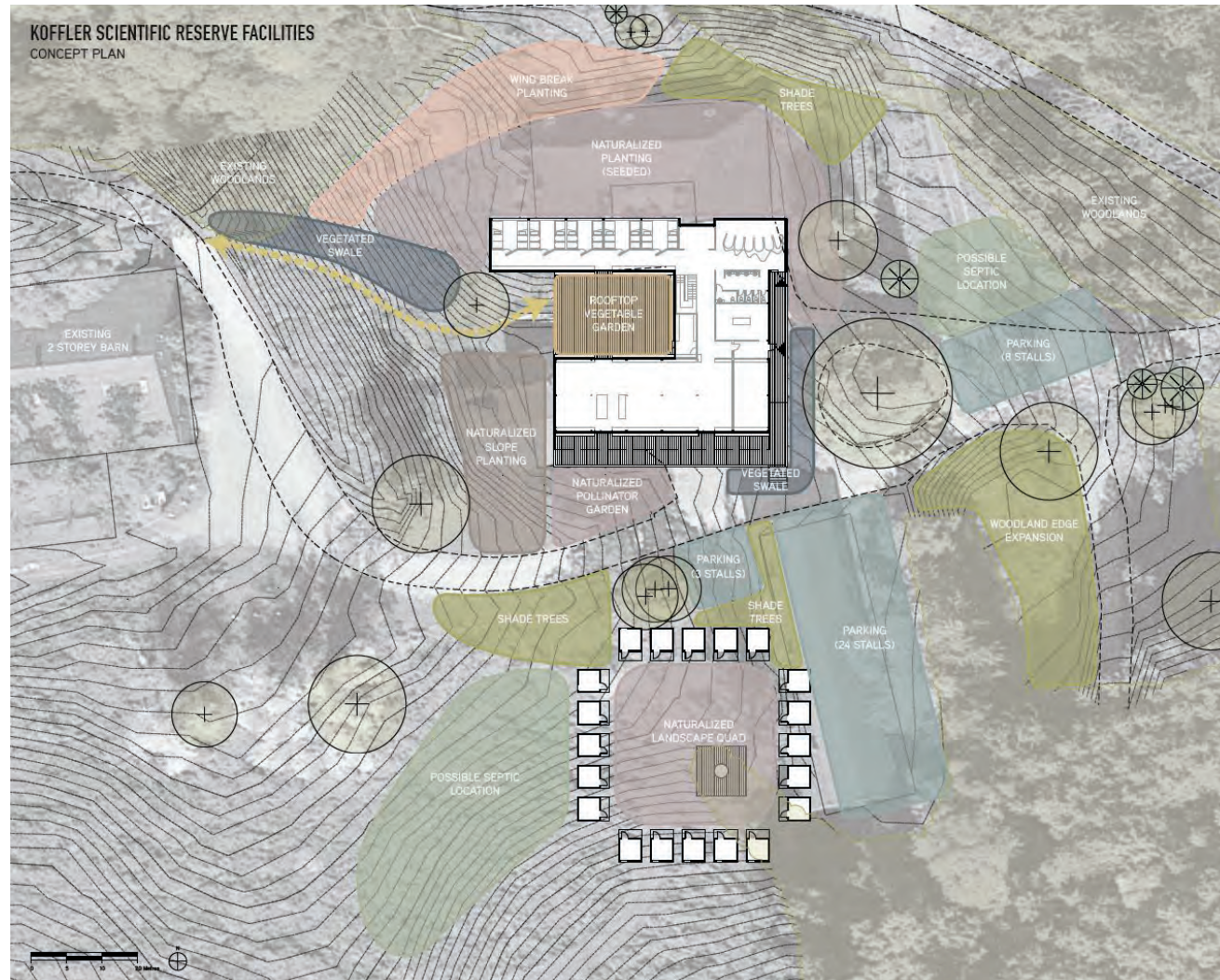

5 ARCHITECTURAL GOALS



## 5. Architectural Goals

Several architectural drivers have been identified for this project:

- Context
- Program
- Form & Material
- Scale

**In the sum of its ambitions, the building is a place for people who would rather be outside...**

## CONTEXT

In the absence of building fabric or road frontage, the building will respond to its **context**. Alignment with the sun, the moon and the stars will improve thermal performance, augment research goals, and help measure the passage of time, in days, seasons, years.

## KOFFLER SCIENTIFIC RESERVE SITE PLAN

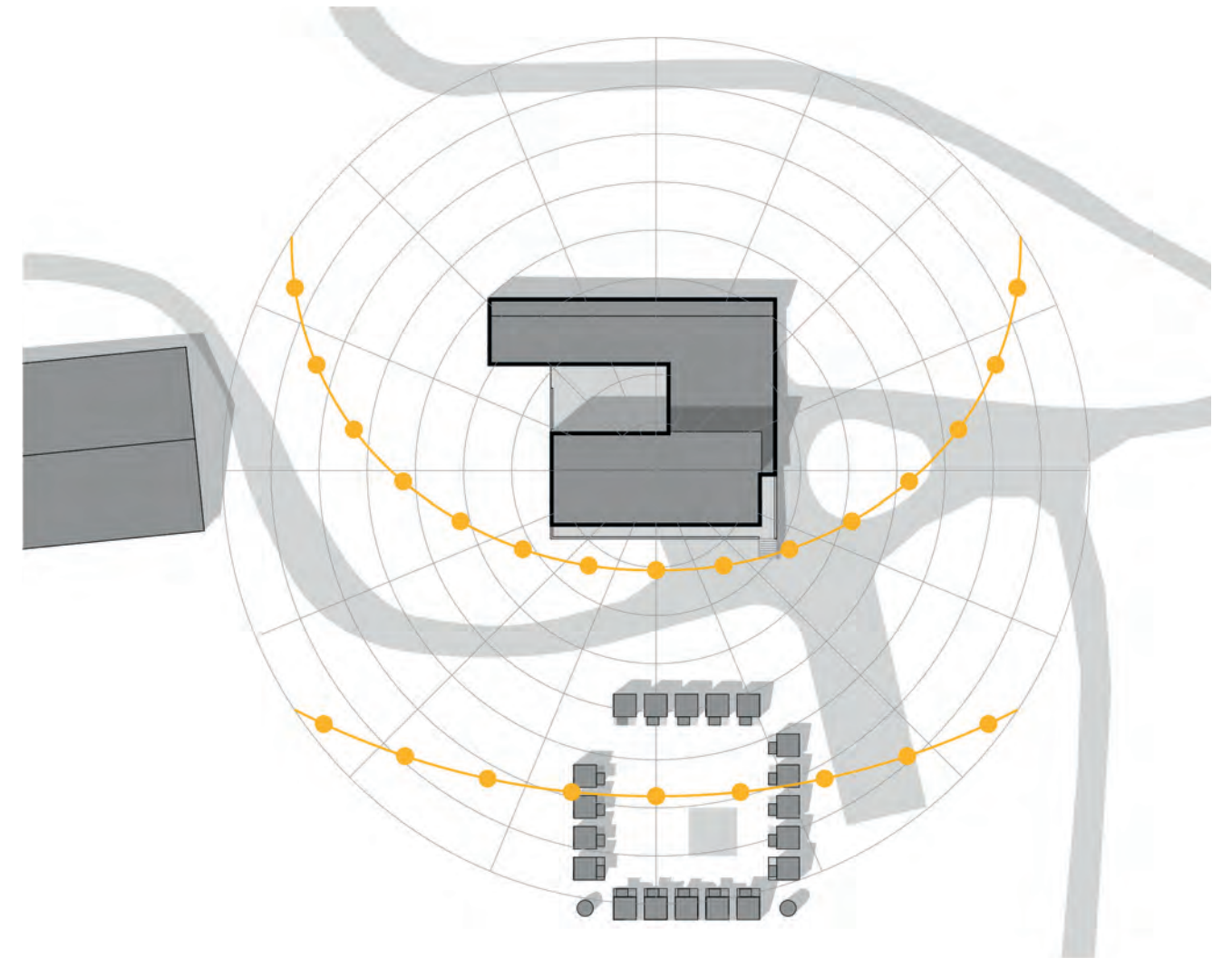





- 1 Existing 2 Storey Barn
- 2 Courtyard
- 3 Main Building
- 4 Drop Off
- 5 Bunkies

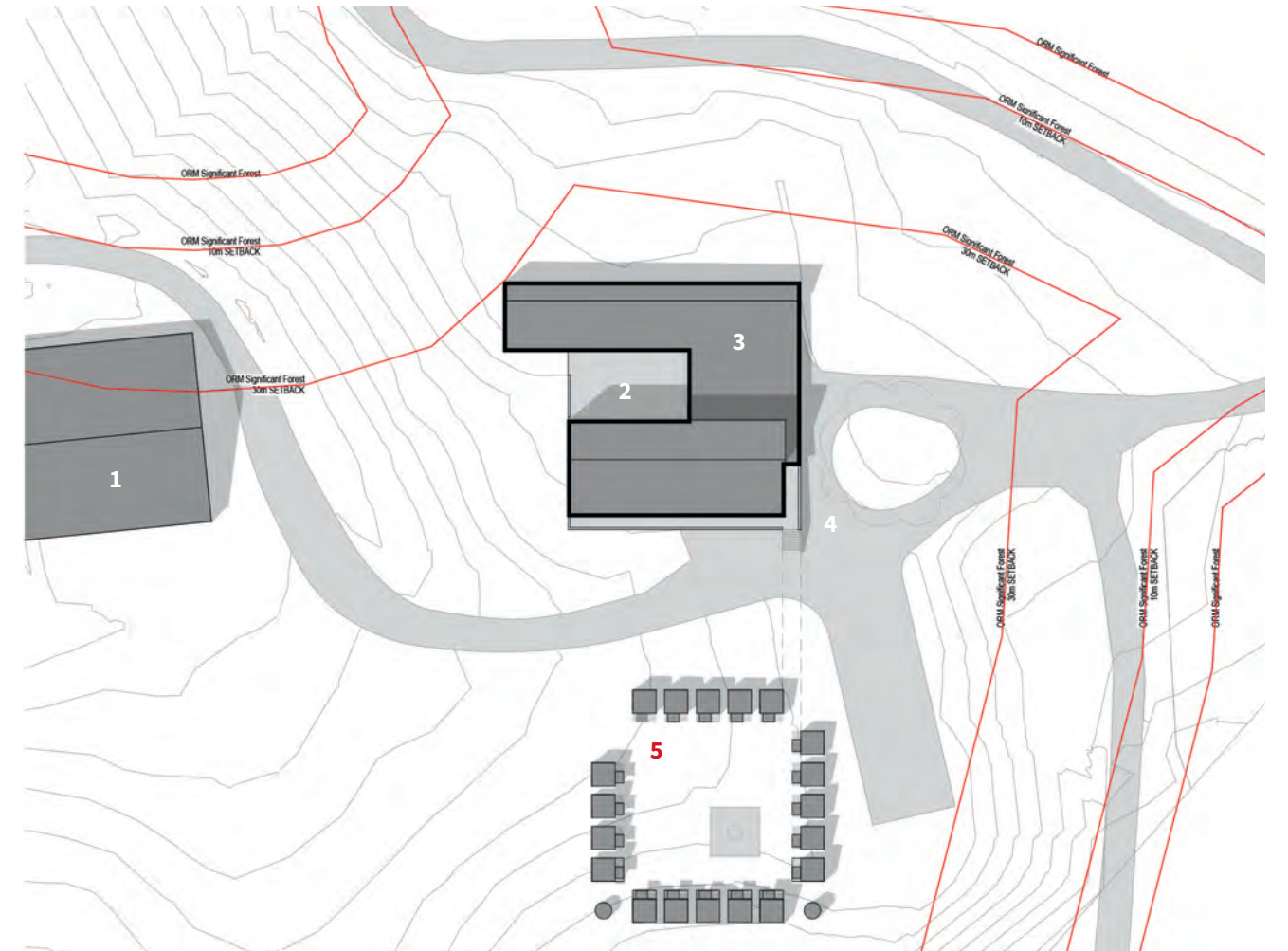

**PROGRAM**

- 1** 4-Person Bedroom
- 2** Lounge
- 3** Showers
- 4** Washrooms
- 5** Office
- 6** Classroom
- 7** Fireplace Lounge
- 8** Kitchen
- 9** Mud Room

**Program** will reflect the functions of a typical of a college with dormitory, refectory, bathing facilities, commons rooms, sitting rooms and gathering hall. The building will also share similar features to a college such as a cloister and quad.

**KOFFLER SCIENTIFIC RESERVE  
GROUND FLOOR PLAN**

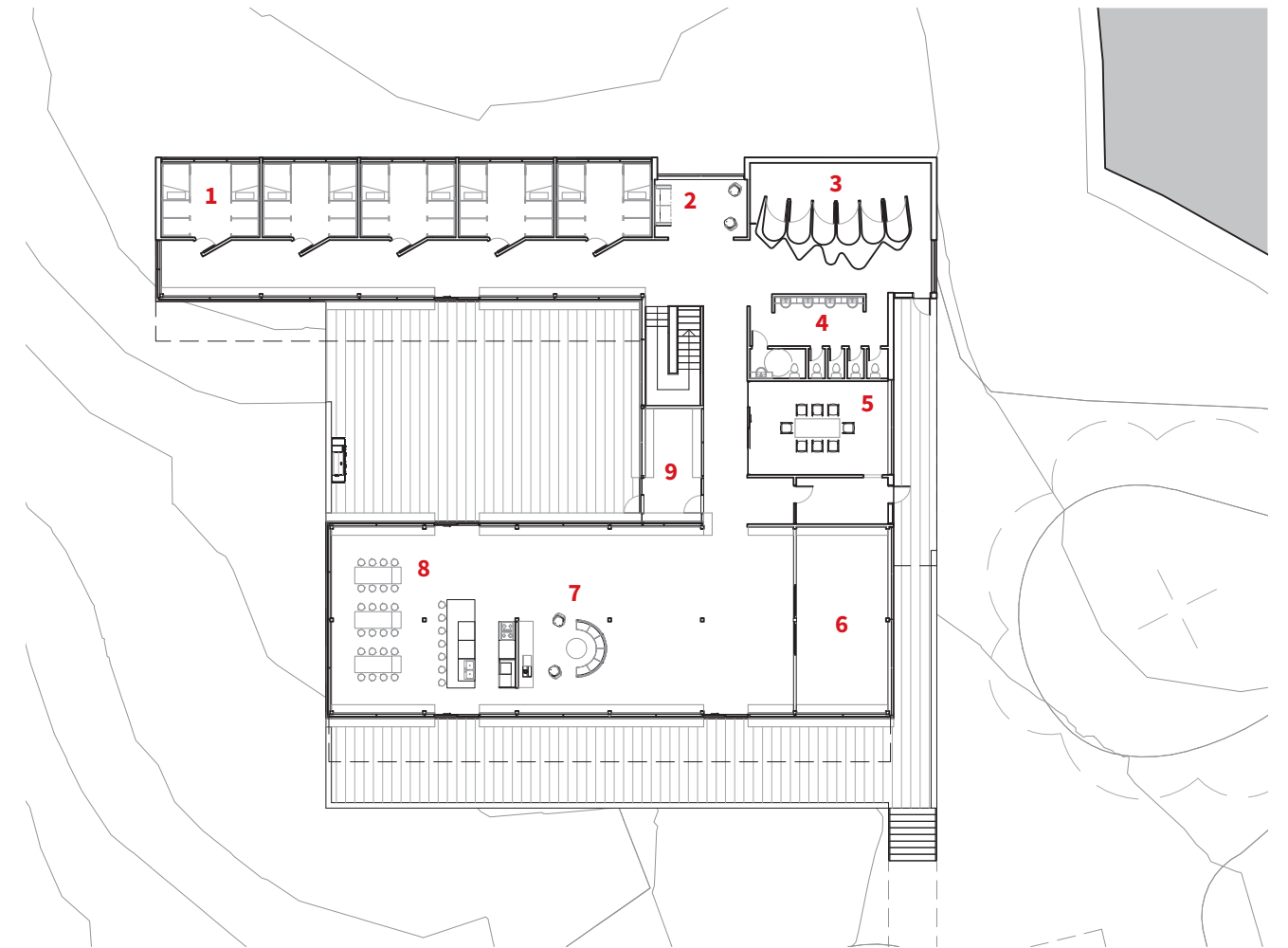



- 1 Storage
- 2 Laundry

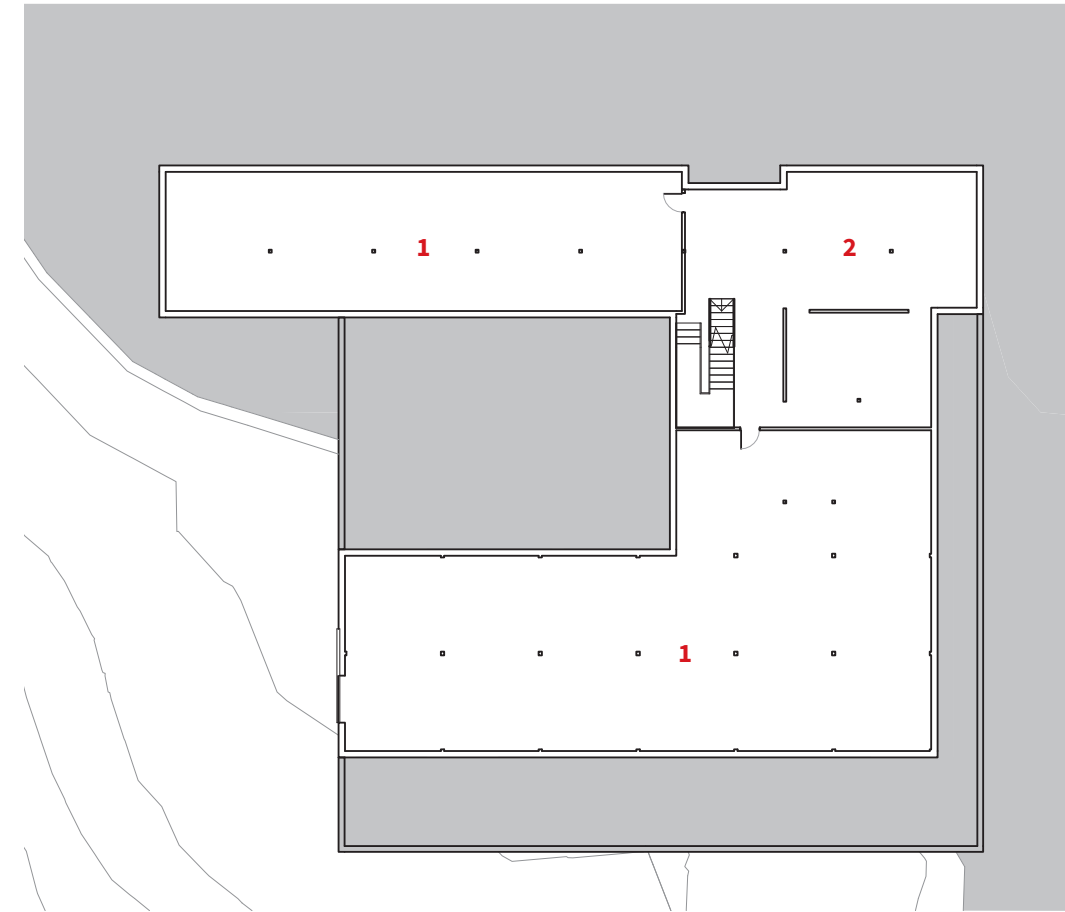

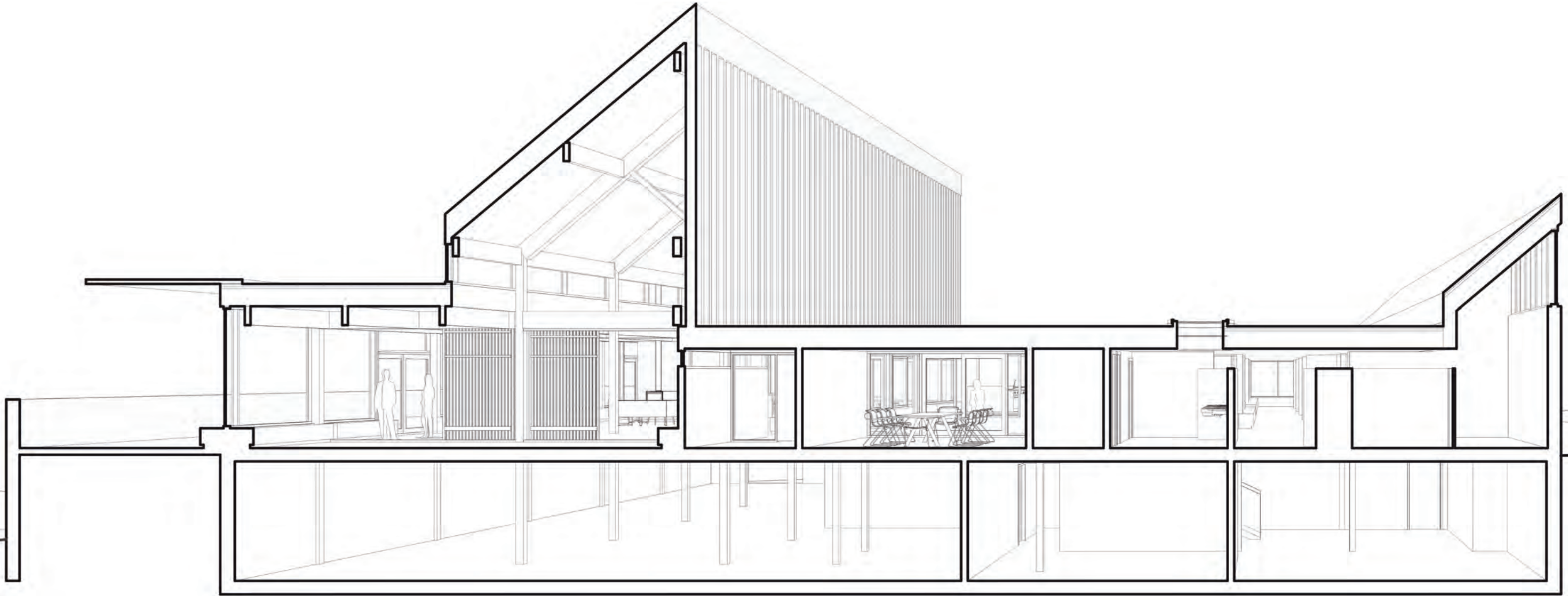

FORM AND MATERIAL

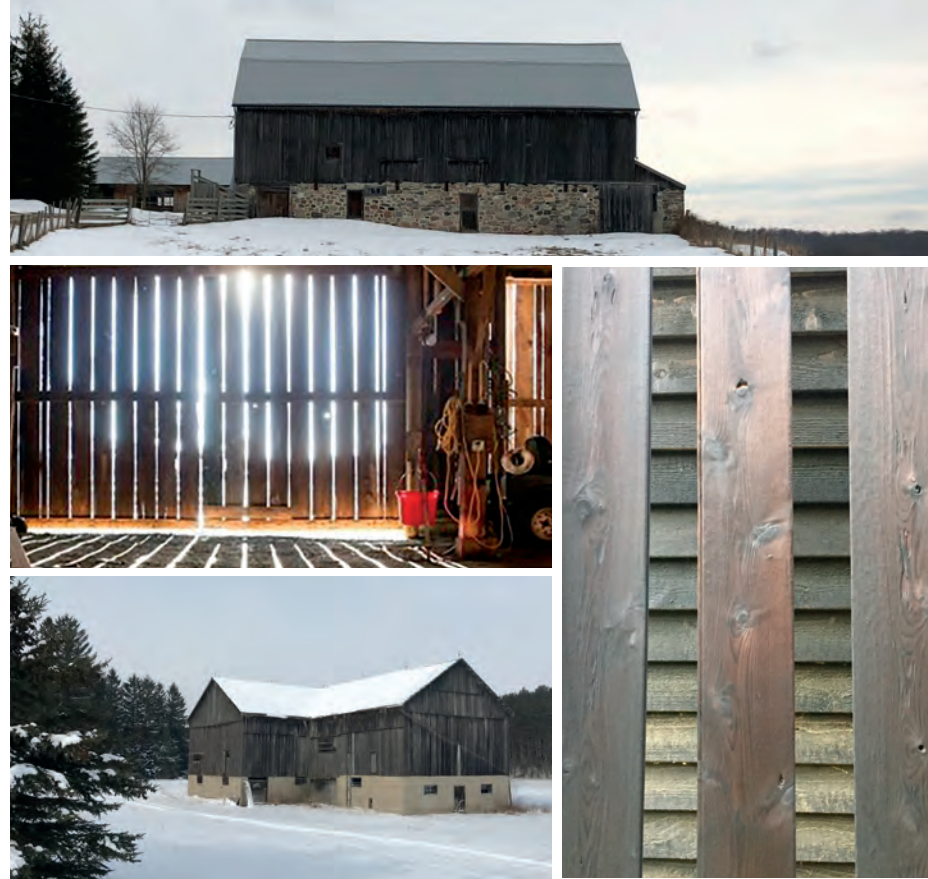

**Form** and **Material Palette** will be an interpretation of agrarian buildings typical of this landscape – primarily barns, sheds and other utilitarian out buildings. This palette will also contribute to the sustainable goals of the project.

KOFFLER SCIENTIFIC RESERVE

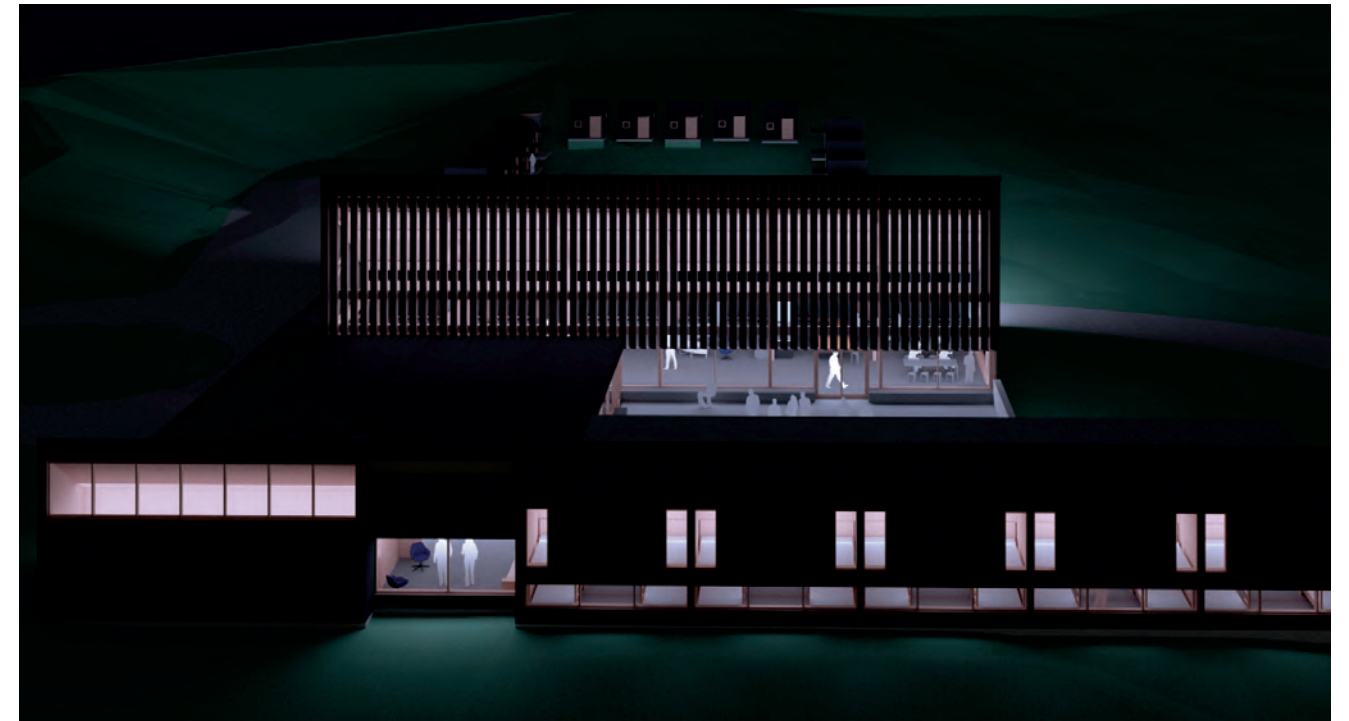

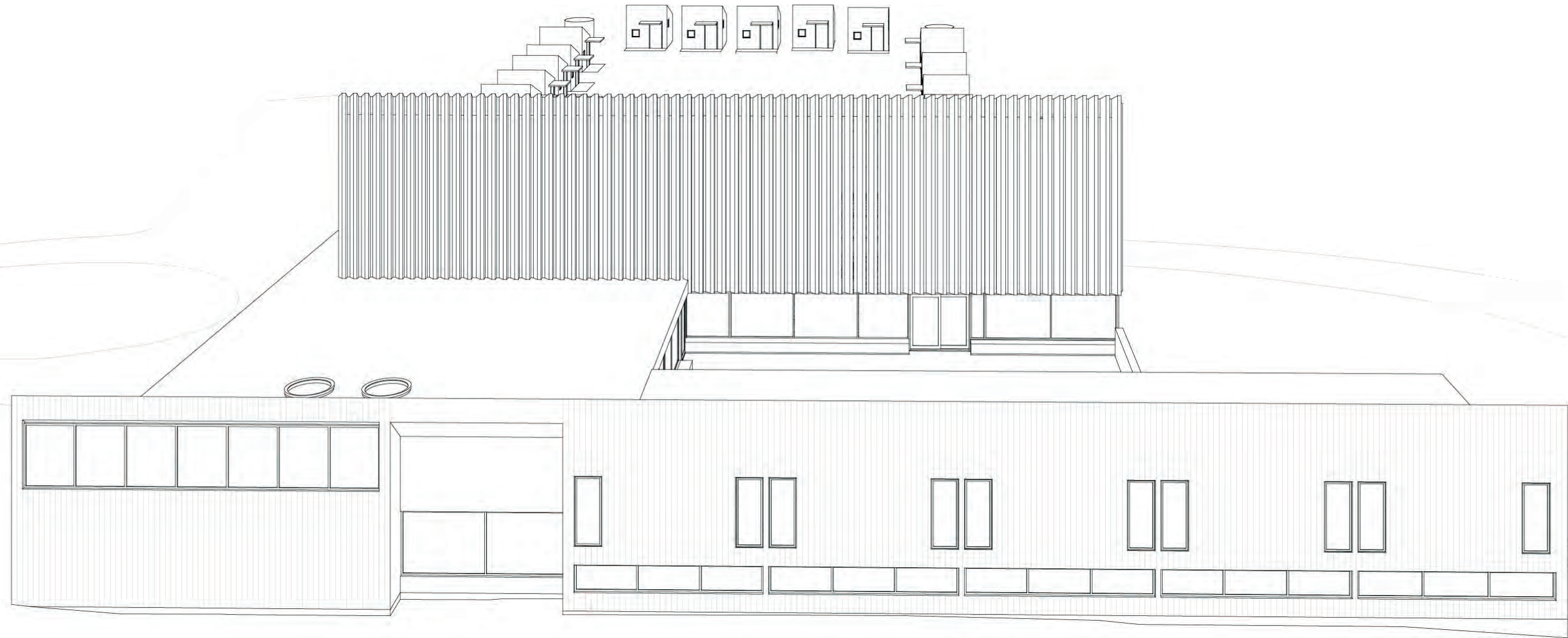

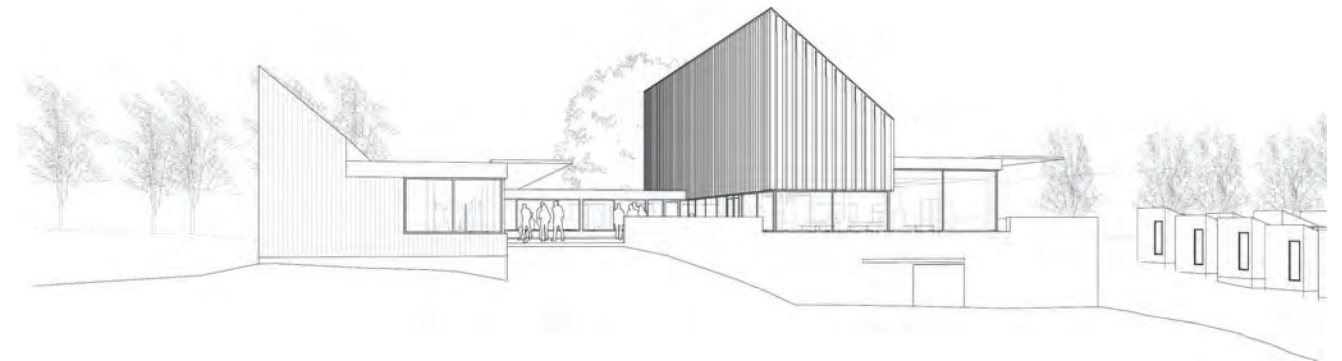
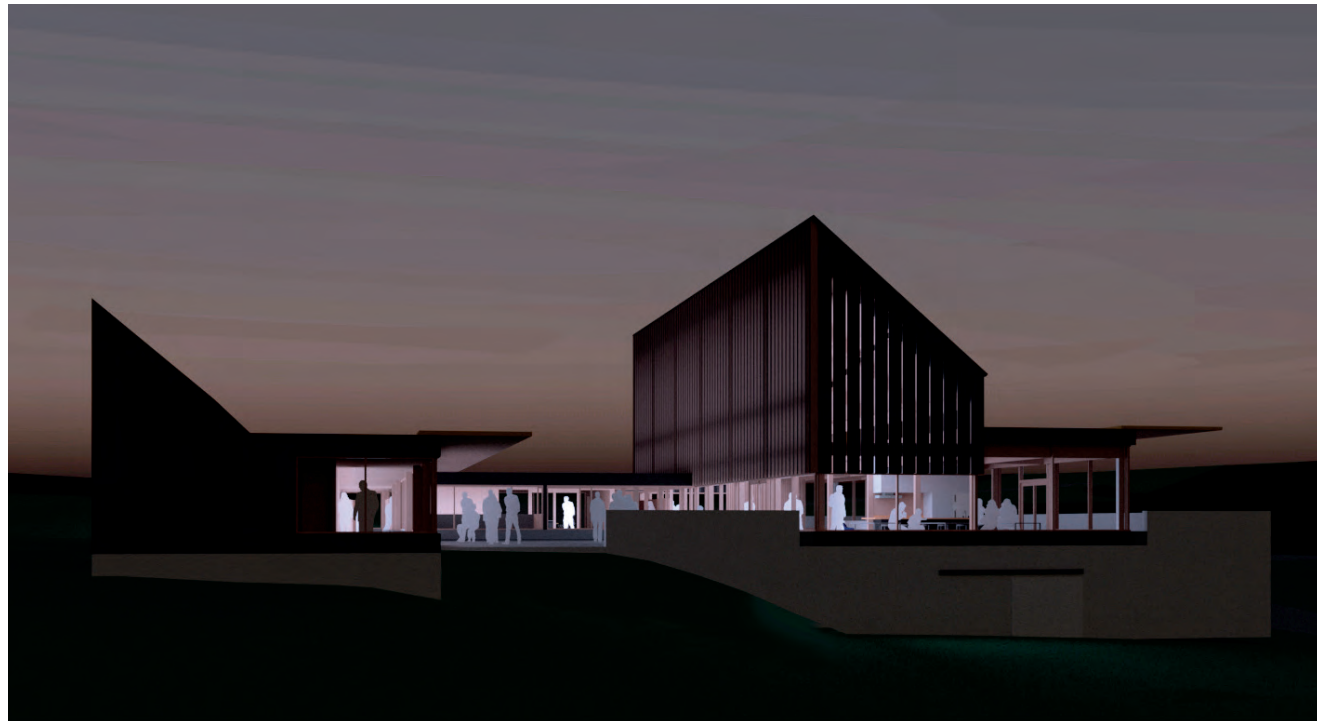

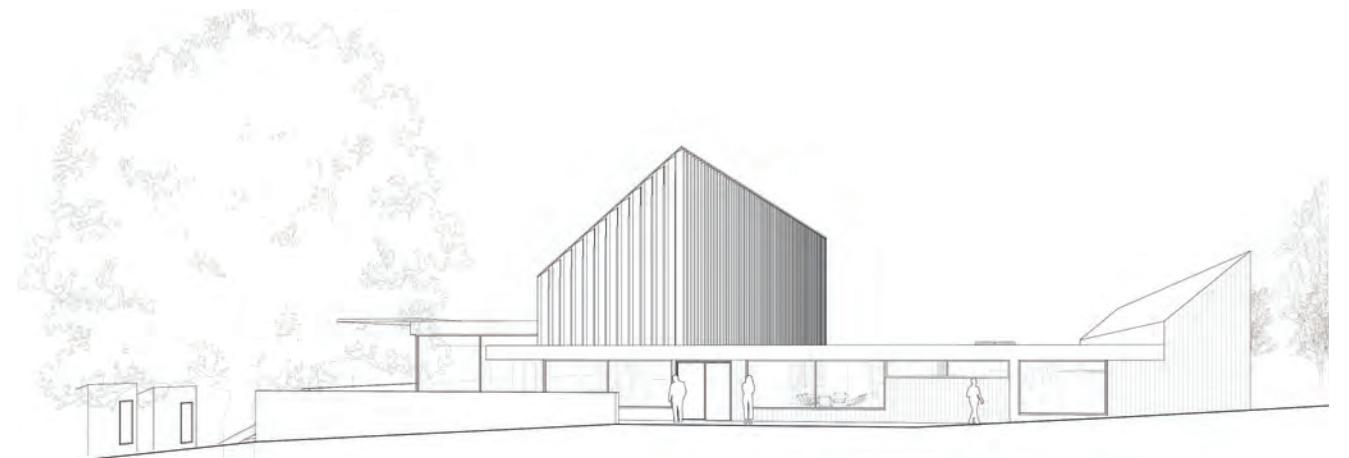
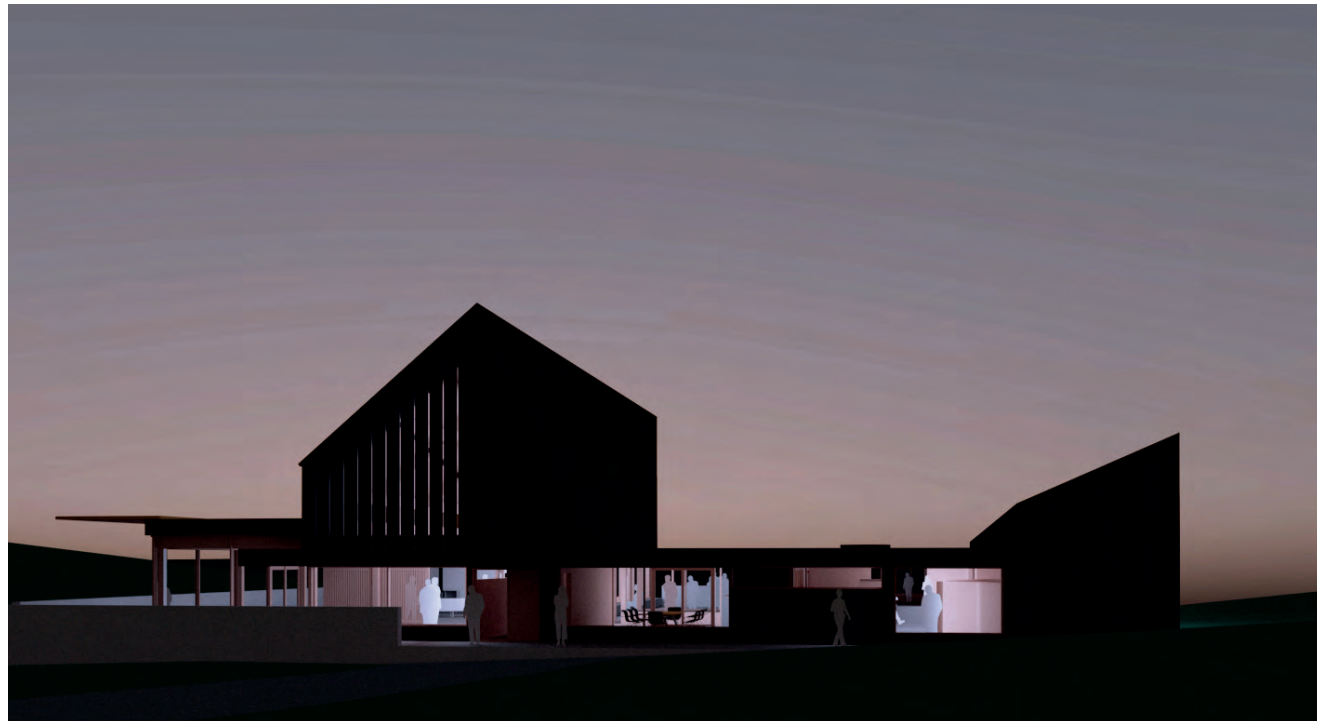



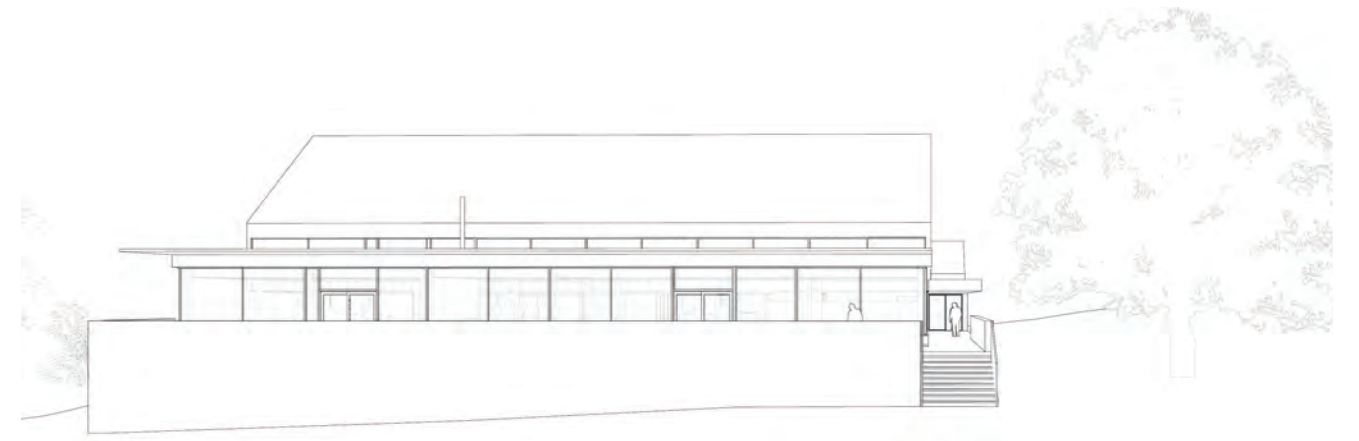
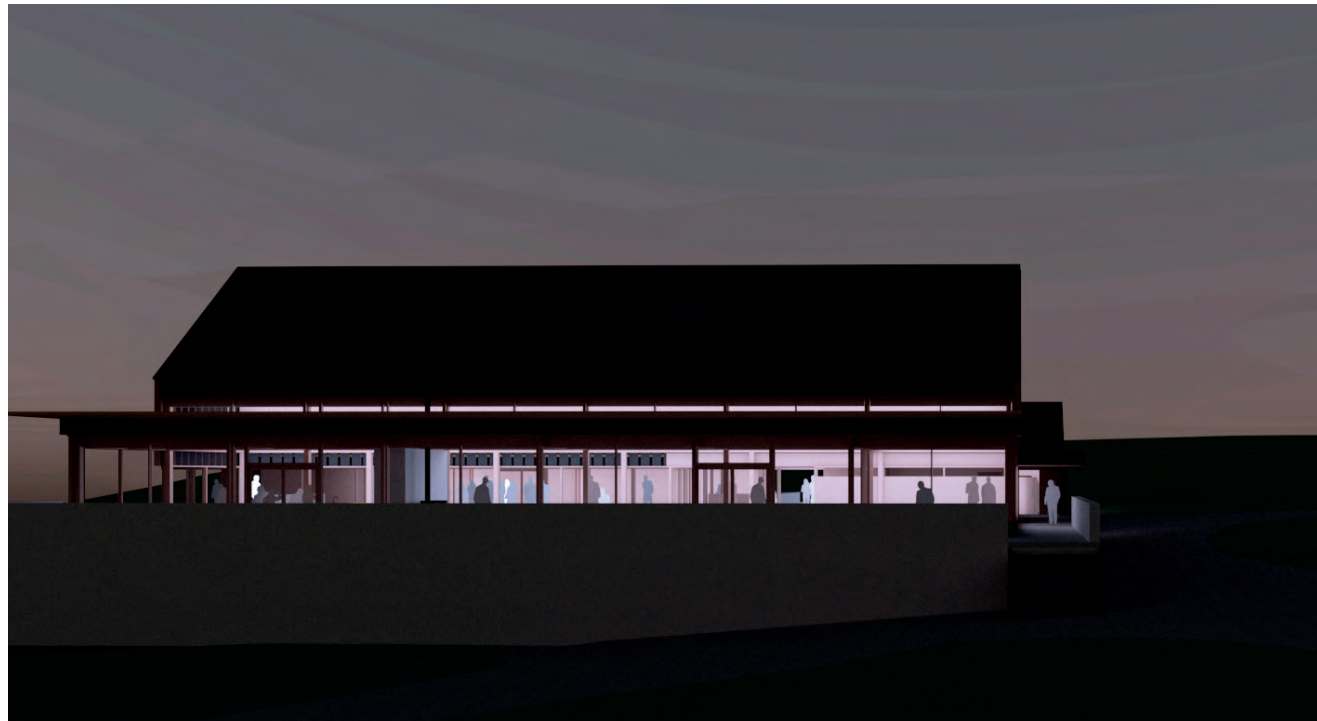

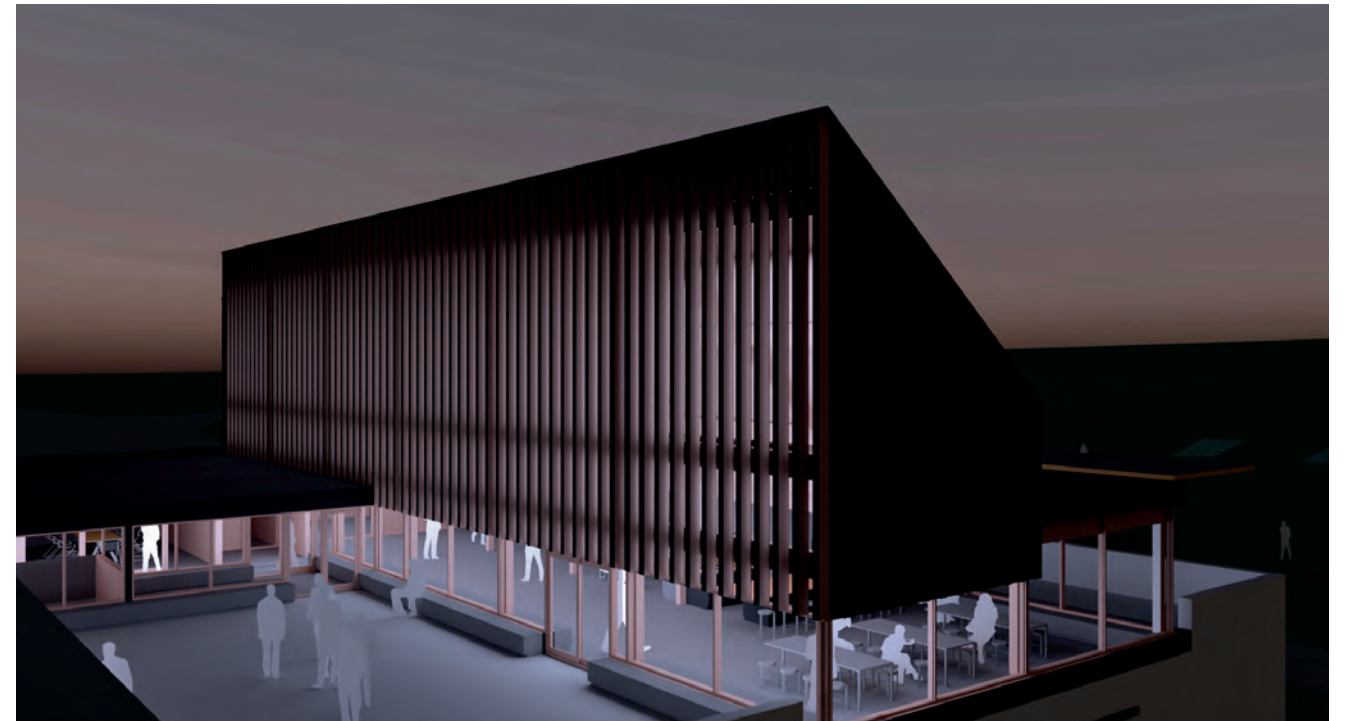
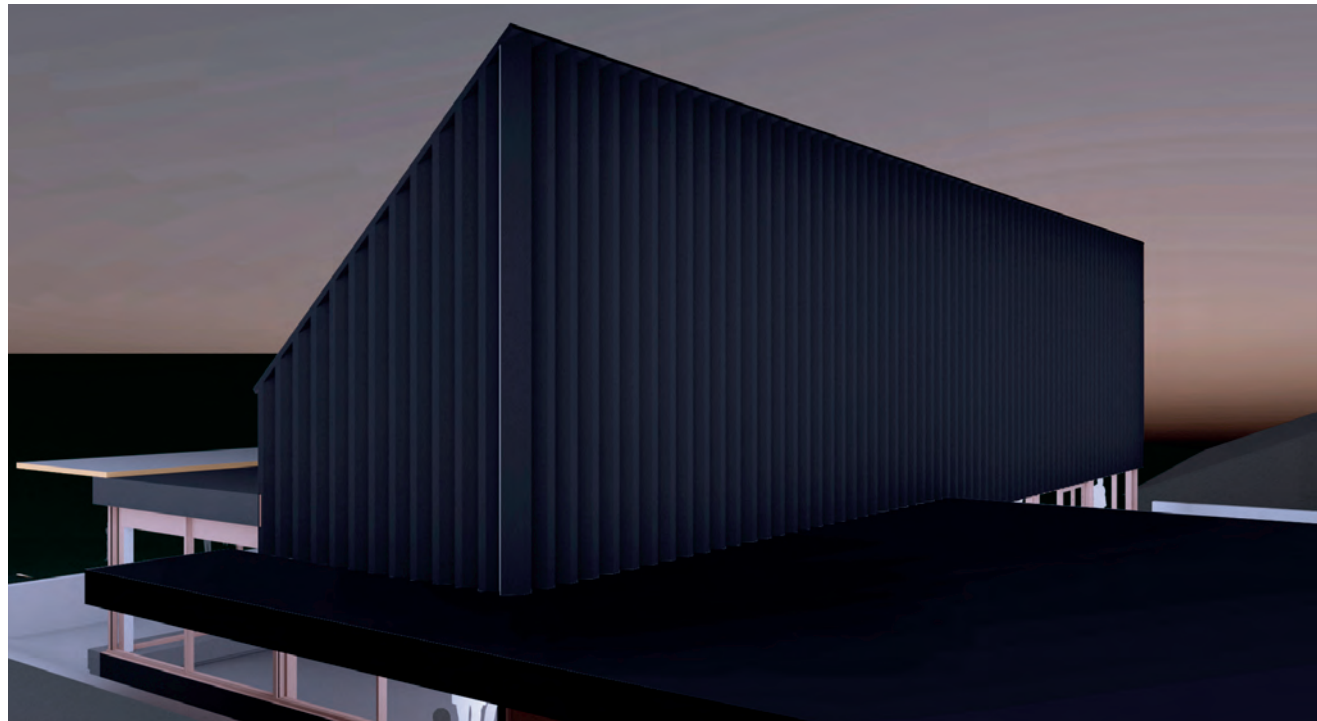

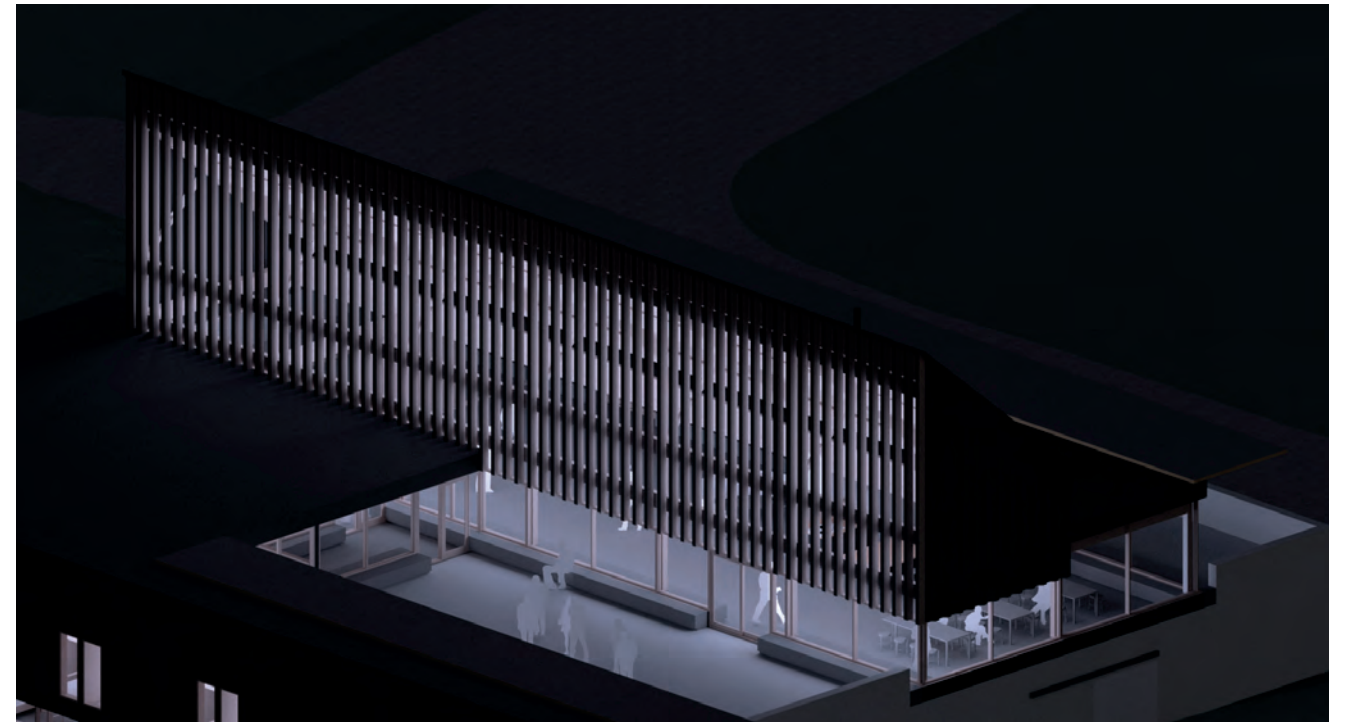
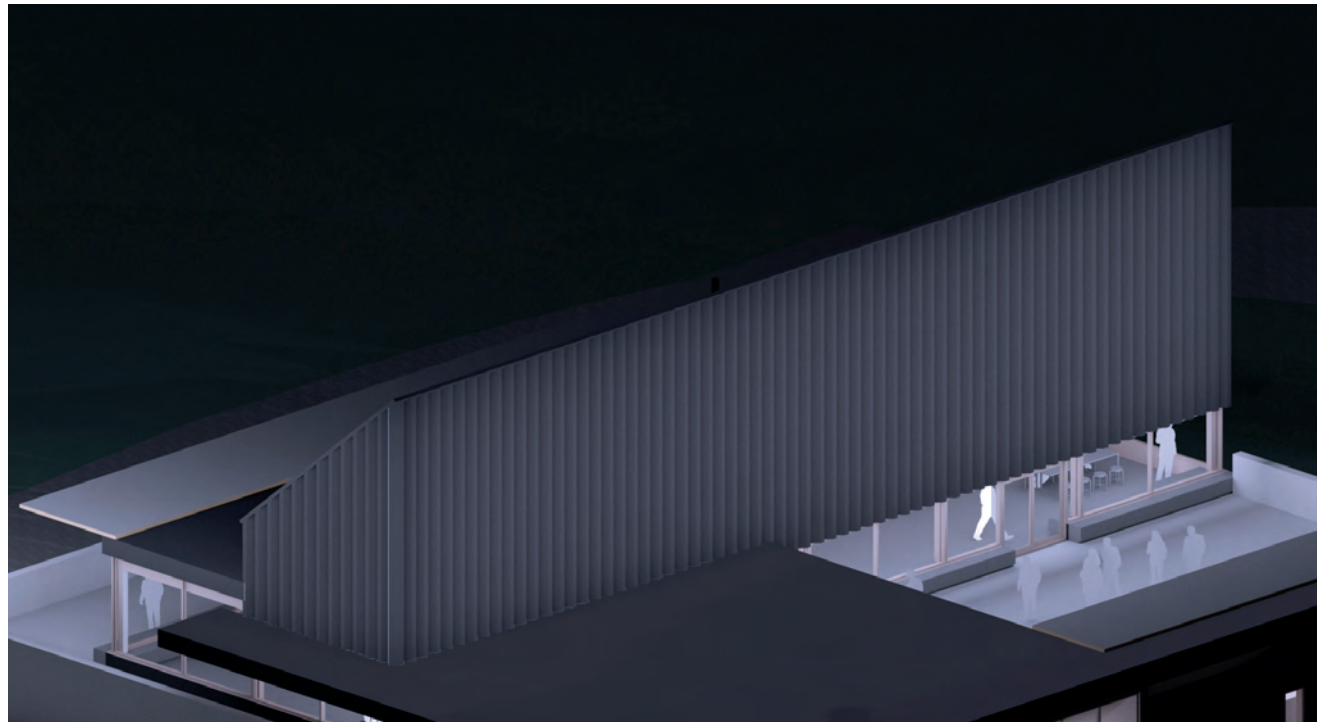

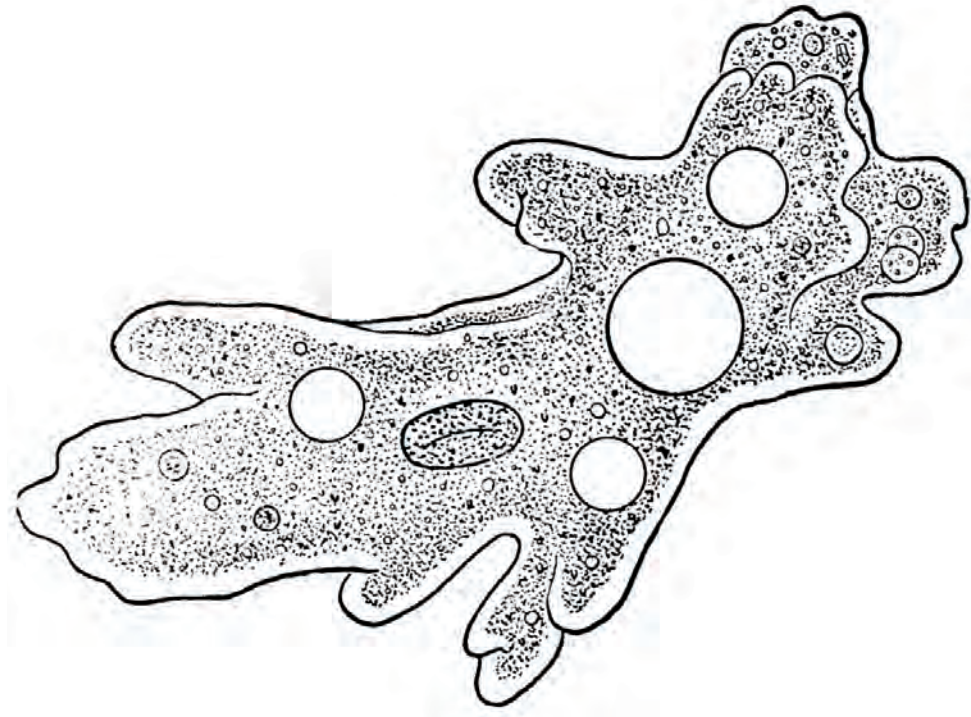

**Scale.** Researchers at the Reserve investigate from the smallest micro organism to the largest scientific systems. The design is inspired by this micro and macro interchange and will make explicit the relationship between the parts and the whole – as an example, the shower plan in the form of an amoeba. We will be investigating further opportunities through detailed design.

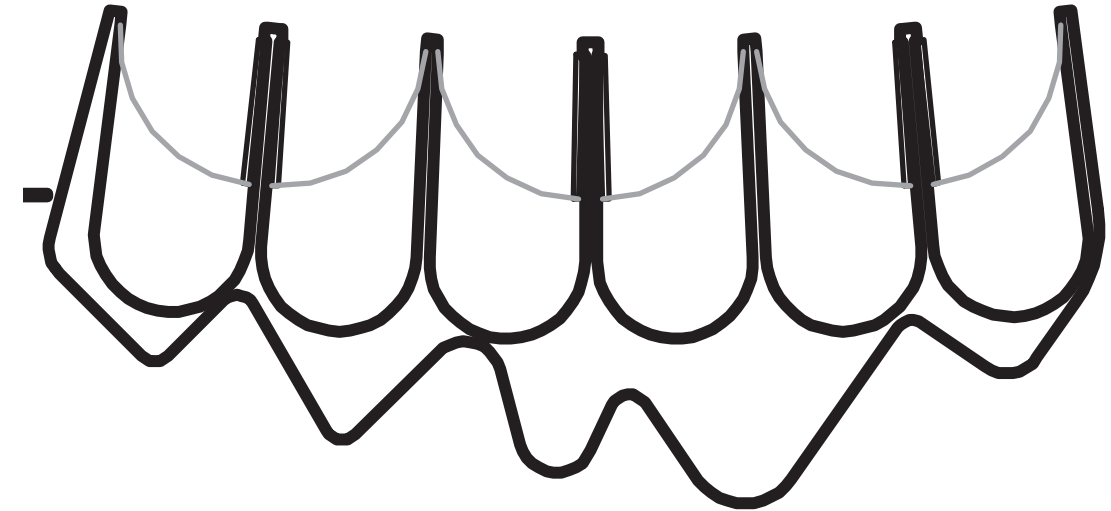

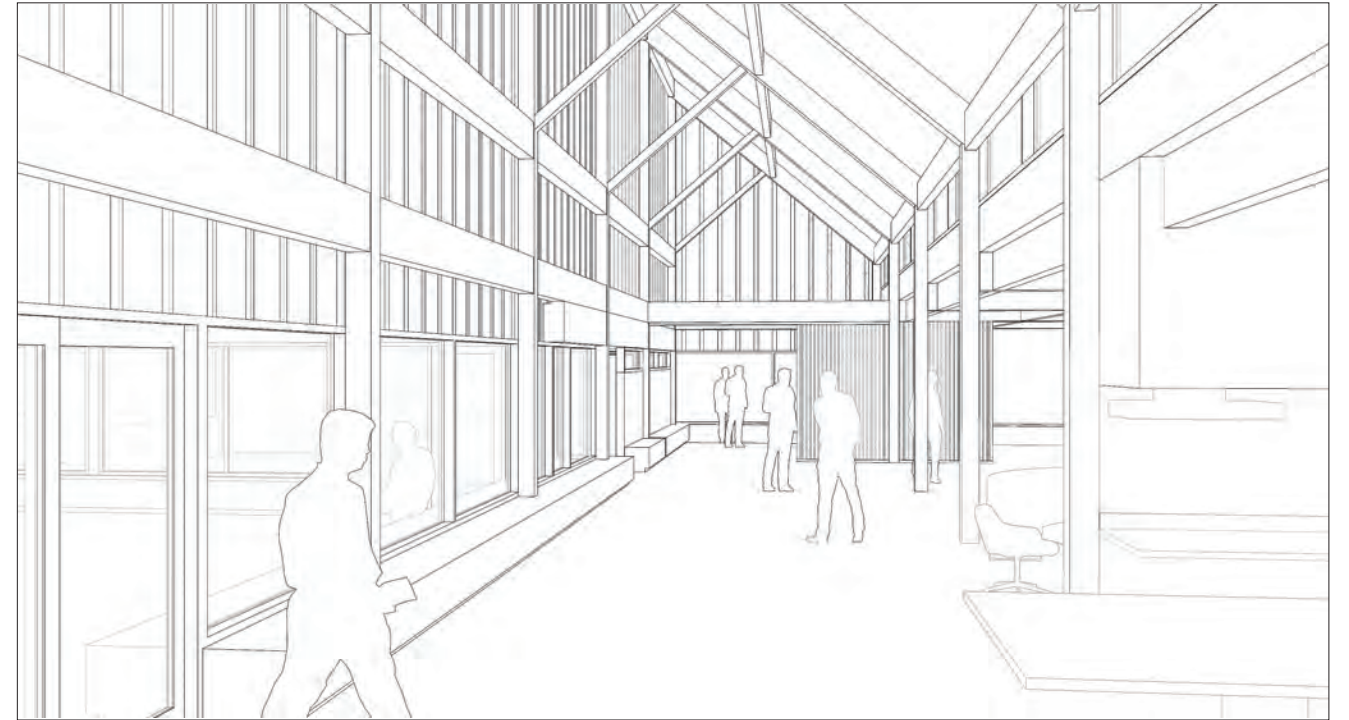

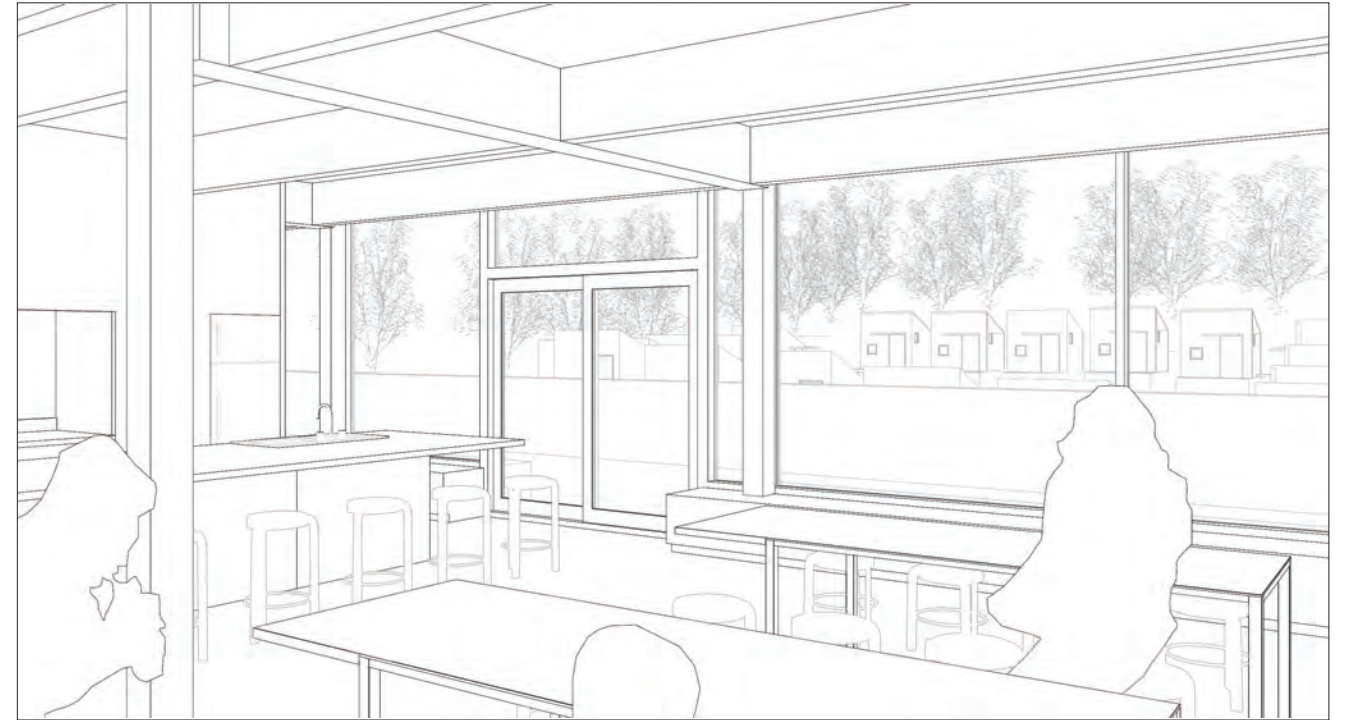
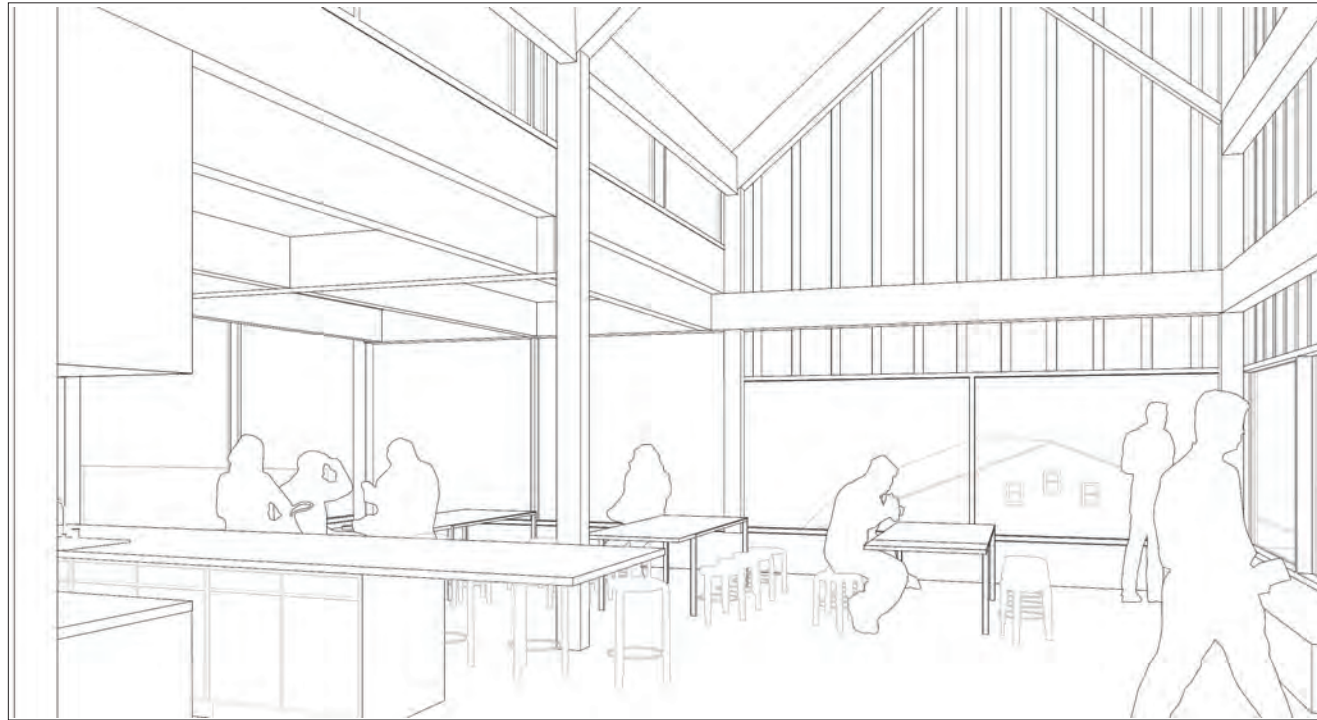

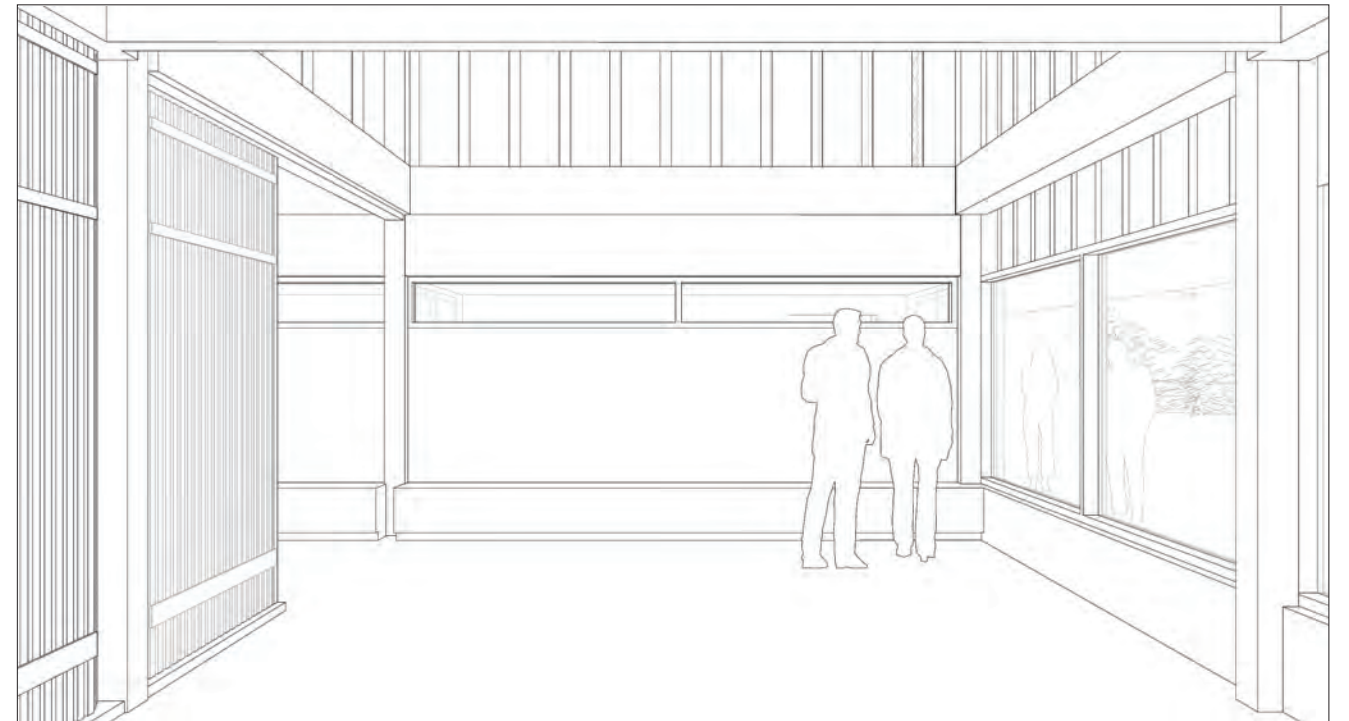
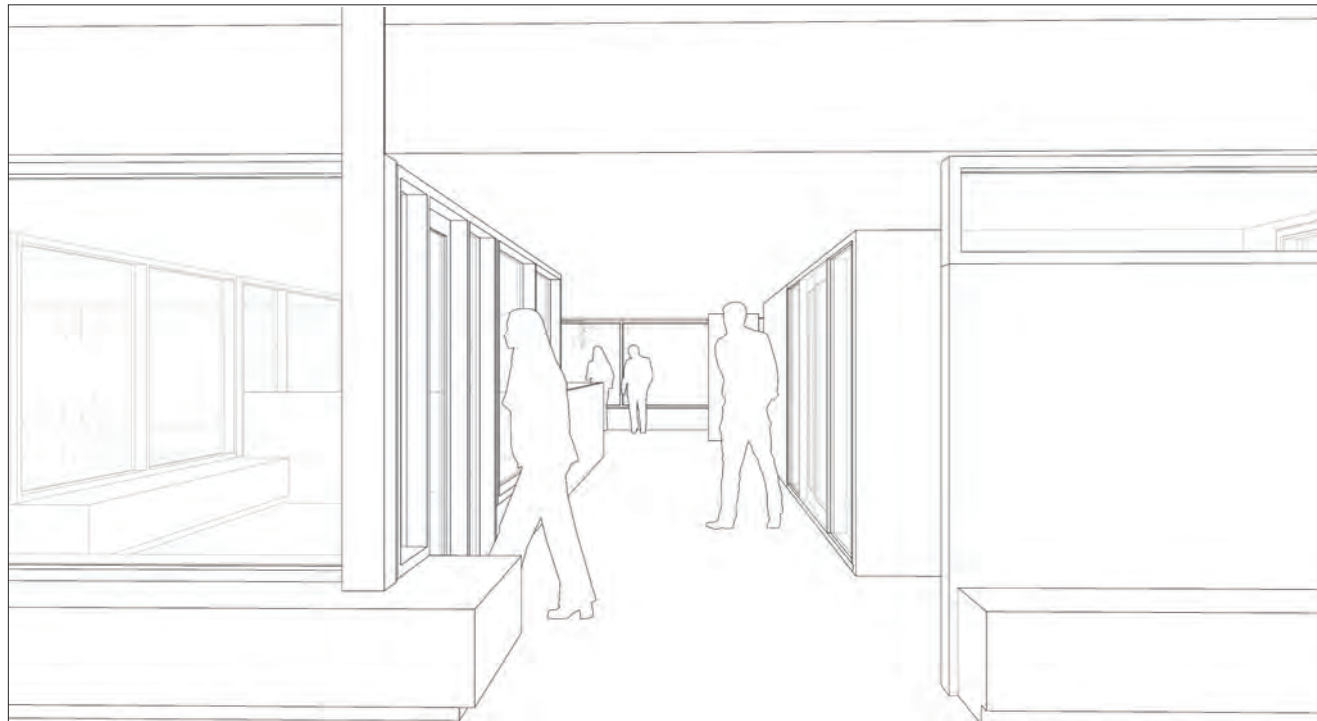

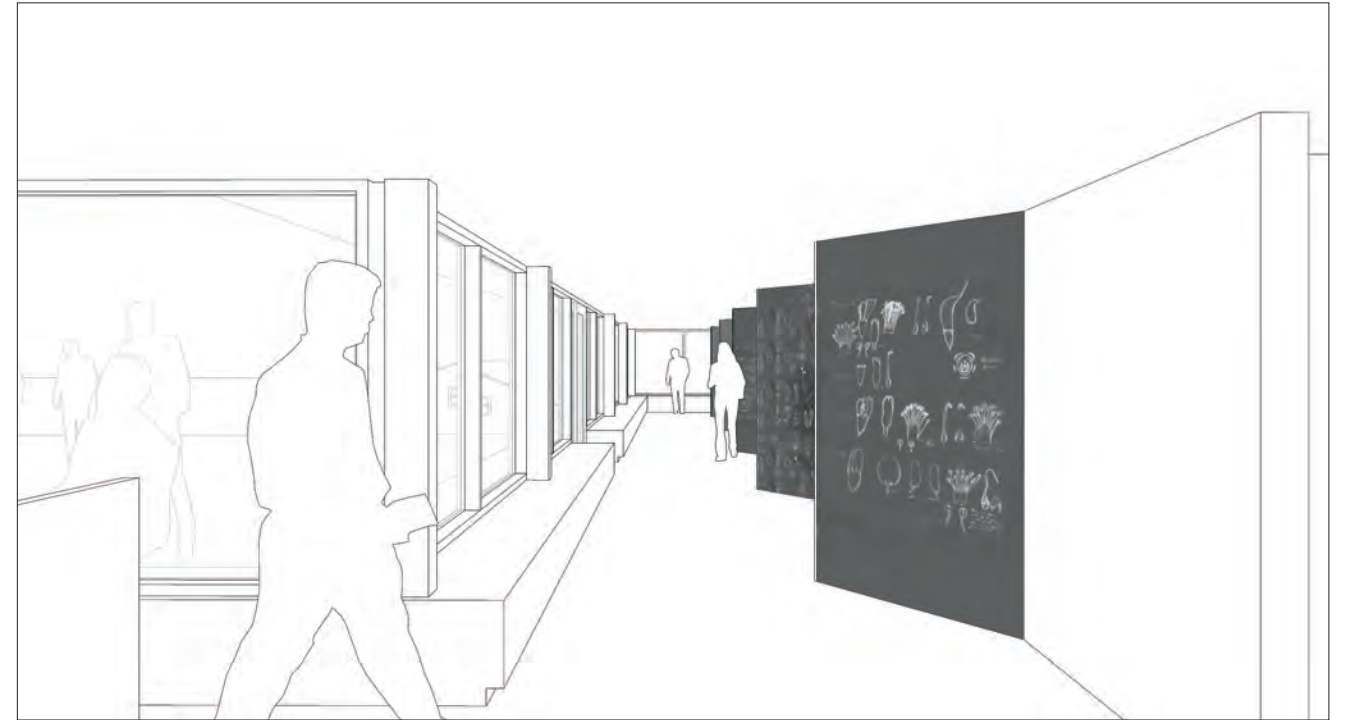



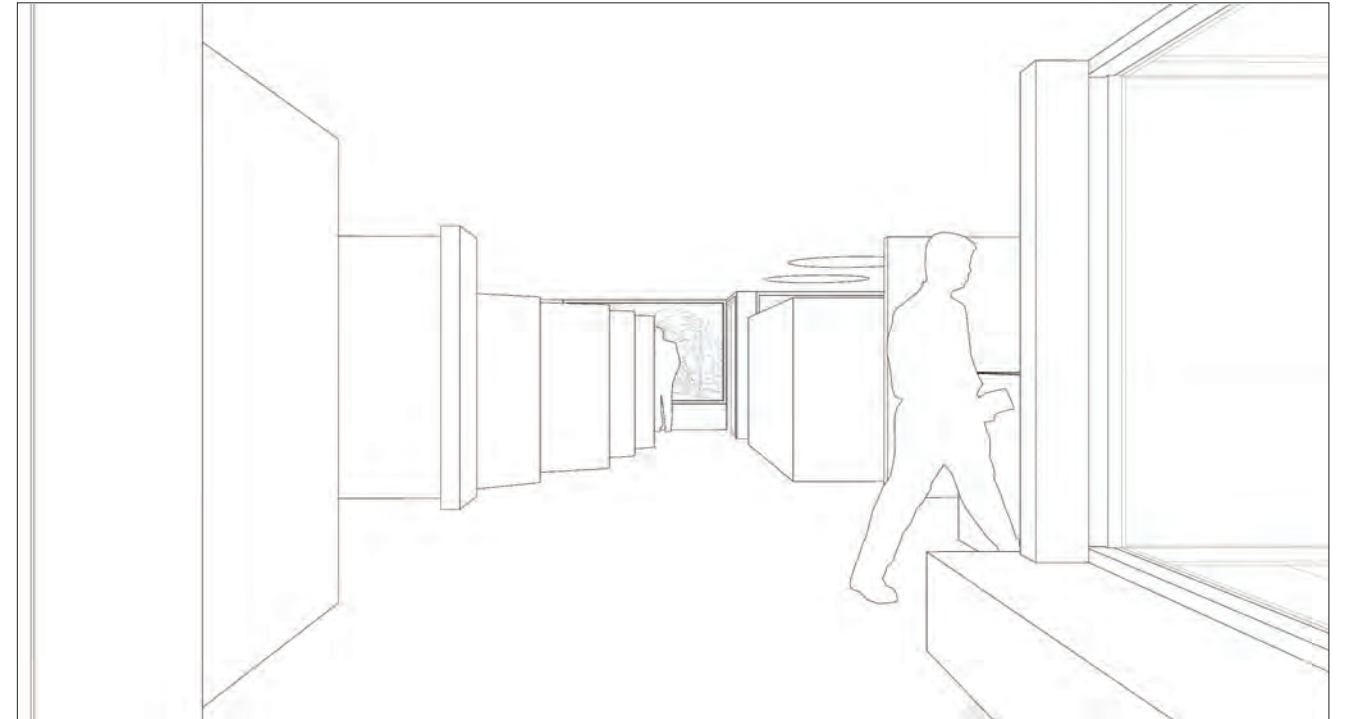
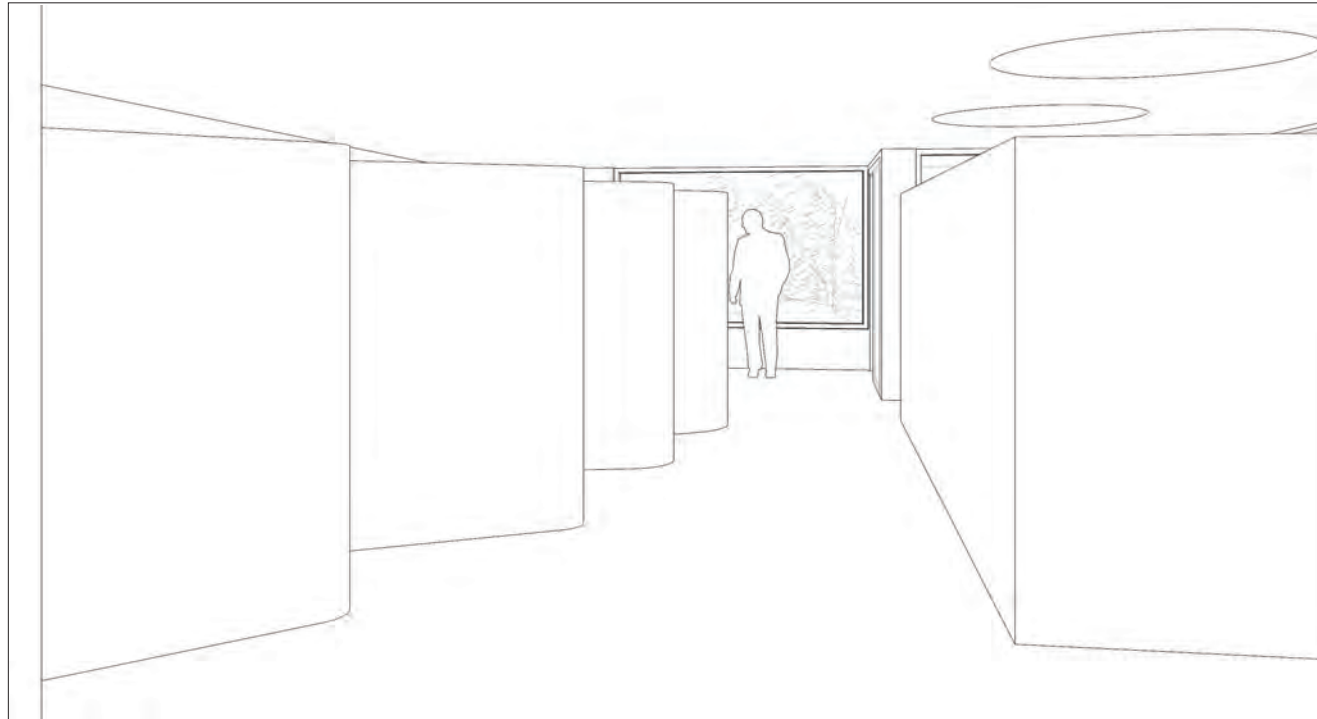

**BEDROOM SECTION**



**KOFFLER SCIENTIFIC RESERVE  
SHOWER SECTION**

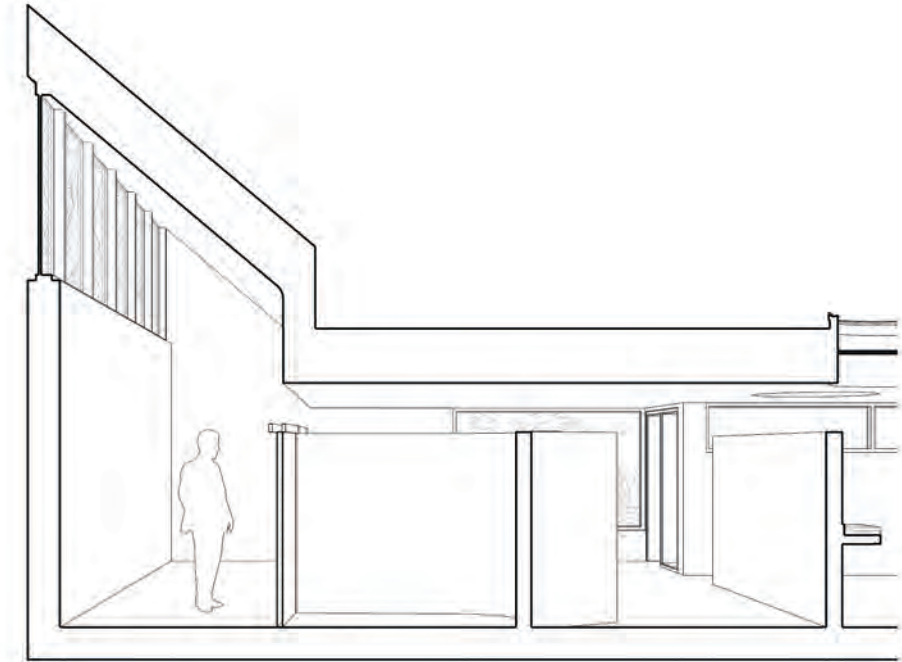

*To See a World in a Grain of Sand  
And a Heaven in a Wild Flower  
Hold Infinity in the Palm of your hand  
And Eternity in an hour. (1 – 4)*

– WILLIAM BLAKE, AUGURIES OF INNOCENCE –

**Montgomery Sisam Architects Inc.**

197 Spadina Avenue, Suite 301

Toronto, Ontario M5T 2C8

Tel 416.364.8079 Fax 416.364.7723

[www.montgomerysisam.com](http://www.montgomerysisam.com)